



Grist Mill
Smartgrist.
LEFA

Innovations for a **better world.**

BUHLER

The ideal grist mill for small breweries. Simple integration into your plant.

The Smartgrist LEFA 4-roller grist mill from Bühler grinds malt and barley into husks, grist and flour in two passages. The preservation of the husks as well as the milling with a 4-roller grist mill lead to shorter lautering times and higher brewhouse yield by comparison with the 2-roller grist mill.

The Smartgrist is very simple and intuitive to operate. The milling gap can be adjusted individually and quickly and is displayed clearly. The optimum product feed is controlled through precise setting of the feeding gap.

Versatile to use.

The 4-roller malt grist mill is suitable for installation in industrial plant too thanks to its pressure shock resistance of up to 0.5 bar. The compact and elegant stainless steel design is also ideally suited for show breweries. With its specially tempered titanium rolls, the Smartgrist grinds malt as well as barley.

High degree of operational safety.

The Smartgrist LEFA malt grist mill is fitted with an optional permanent magnet in the feed gate, which holds back metal parts. The roll package is spring-loaded so that the milling gap can open if a stone passes through, for example. Also, the machine is very low-maintenance.

Benefits.

- Versatile to use
- High degree of **operating safety**
- Fits into a **small space**
- **Gentle grinding** of malt and barley
- **Pressure shock resistant** design



Requires only a small footprint. The mill for direct mashing.

Requires only a small footprint.

The Smartgrist LEFA is suitable for direct mashing without grist containers for brew sizes of up to 20 hl. Eliminating containers and conveying elements means that less space is required and the oxygen intake is reduced to a minimum. Indirect mashing of up to 40 hl per brew is also possible with the Smartgrist.

Options.

- Additional hopper for increasing volumes to 80/150 liters
- Machine frame with sampler for quick checking of the ground product

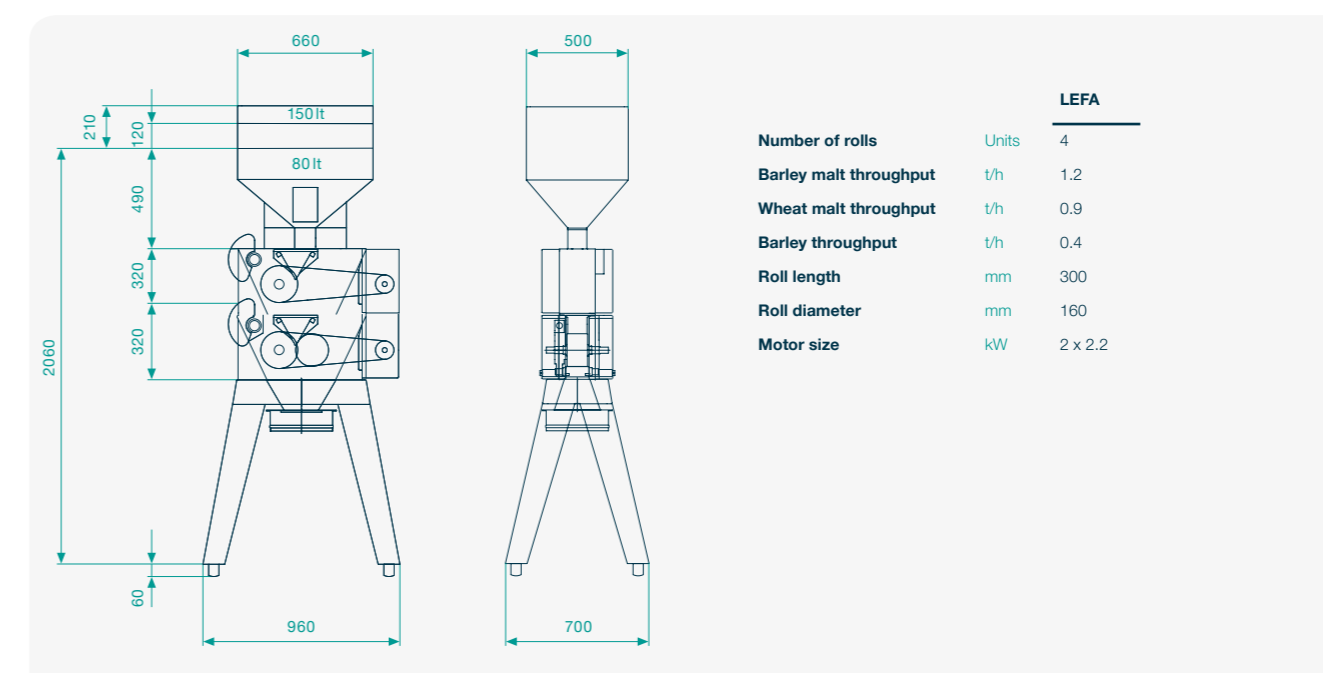
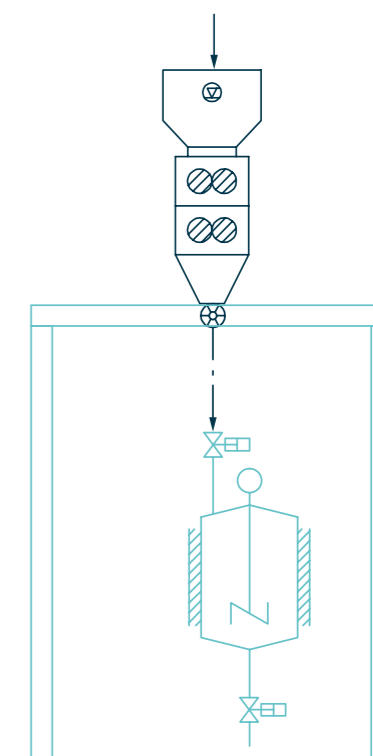

Bühler GmbH

92339 Beilngries
Deutschland

T +49 8461 701 0
F +49 8461 701 133

grain-quality-supply@buhlergroup.com
buhlergroup.com/mb

GQ_MF_LEFA_EN_14229_01