



ASADOTM
PARILLA GRILL



STODDART[®]



PARILLA GRILL

SPAS.PGA.EL9.0800

Asado parilla offers a unique style of cooking that originated with the cowboys of Southern Brazil & Argentina called Gaucho's. Meats are slowly cooked over natural wood charcoal resulting in flavoursome, succulent & tender cuts.

The electric powered lift grill is ideal for cooking of steaks vegetables maintaining the authentic woodfired barbeque flavour.

Features

- Grill height adjustable from 950mm to 1550mm
- Electric powered elevation of cooking grill
- Joystick grill height control
- Cantilevered grill frame folds up for clear access to firebox
- Removable cooking grids that fit dishwasher racks
- Convenient cupboard for storage under

Model

- Cabinet is 800mm (W) x 930mm (D) and matches Electrolux 900 series profile
- Grill Frame Cooking Area 522mm (W) x 559mm (D)
- 10Amp 240V, Plug and lead supplied

Also available in 1200mm wide model.

Note to designers & installers :

Live fuel grills have specific ventilation requirements It is the responsibility of designers & installers to ensure that ventilation of live fuel grills is in accordance with the Building Code of Australia as it is referenced to AS1668.2

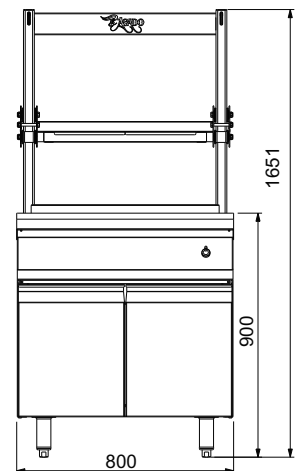
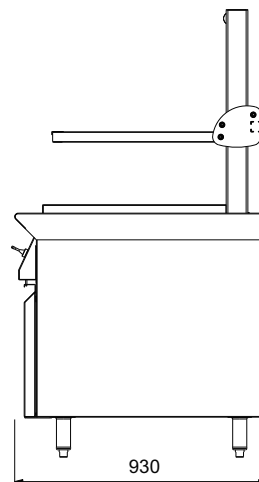
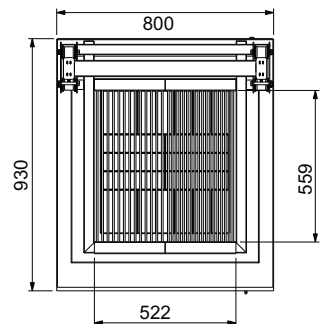

We reserve the right to alter specifications of products without notice. All dimensions are in mm.



For maintaining the Authentic Charcoal cooking flavour

One of the growing trends is toward more traditional ways of cooking with solid fuels instead of gas/electric where the flavour of charcoal is the influence on the styles presented in restaurants.

Currently a number of restaurants are using the Asado units with a number of this growing trend in Hobart where this has taken off and is spreading to the major cities in the rest of Australia.

The Asado is installed in Garagistes and the new Frank restaurants in Hobart and are really making it as a central part of their menu.

For Luke Burgess of Garagiste's, his favourite, and from his point of view, the most important piece of equipment in his kitchen is the Asado chargrill,



"...Because you can't just simply recreate the flavour of charcoal, and cooking produce over wood creates a unique and special texture, flavour and aroma. Whether or not it's essential, it's important to me that it's actually an important method of cookery that I really, really enjoy and it's important to me in the kitchen." Luke says that people all over the world have been cooking over charcoal for a long time, "Our ideas are based on a concept I saw in Northern Spain, but I do believe that it gives us a point of difference when up to 50 percent of the menu can come off the Asado at any point in time."

He's not even sure if his chefs have discovered everything they can do with their Asado Grill,

"Every day there's always something you learn about that piece of equipment."

Brisbane

Sydney

Melbourne

Perth

Adelaide

Manufactured exclusively by:



Dealer

Total
Commercial Equipment

Complete Project Solutions™

(08) 8363 5282
www.totalce.com.au

