

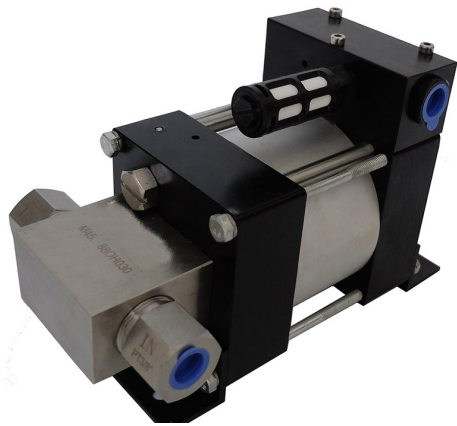

**PROTECH PUMPS**

Air Driven Pumps & Boosters

## **PM SERIES** Air Driven Liquid Pump Single Acting Single 80mm Air Head



- Stainless steel wetted materials of construction
- Specialised construction materials available
- Polyurethane pressure seals as standard
- UHMWPE, PTFE & other special seals available
- Separation & drainage between hydraulic & pneumatic seals
- No airline lubrication required
- Compact & lightweight
- Suitable for most hazardous areas
- Available as a complete packaged system (ProPak)

Model	Actual Pressure Ratio	Displacement cu ins / cc	Max Outlet Pressure PSI / BARG*	Connection Inlet A/Outlet B	Flow refer Page
PM9	10:1	0.92 / 15.08	1,160 / 80	3/8" NPT / 3/8" NPT	7
PM15	16:1	0.58 / 9.43	1,856 / 120	3/8" NPT / 3/8" NPT	7
PM22	25:1	0.37 / 6.03	2,900 / 224	3/8" NPT / 3/8" NPT	7
PM40	45:1	0.20 / 3.35	4,640 / 360	3/8" NPT / 3/8" NPT	8
PM60	64:1	0.14 / 2.36	7,424 / 512	3/8" NPT / 3/8" NPT	8
PM100	100:1	0.09 / 1.51	11,600 / 800	3/8" NPT / 3/8" NPT	8

\* Maximum outlet pressure at an air drive of 8 bar / 116 psi

## NOMINAL AND ACTUAL RATIO EXPLAINED

ProTech Pump model numbers reflect the pumps nominal pressure ratio, while the technical data indicates exact actual ratios.

The outlet stall pressure is easily set by adjusting the air drive pressure through a simple air pressure regulator. By multiplying the actual pressure ratio by the available shop air pressure, the maximum outlet liquid pressure (stall) can be calculated.

Example ProTech Pump Model:

### PG-60 liquid pump

**Air drive piston area (160mm Ø)= 20,108 sq.mm**

**Hydraulic plunger area (20mm Ø)= 314 sq.mm**

**Actual ratio= 64:1**

ProTech Pumps are pneumatically driven reciprocating plunger pumps and can be used at drive pressures of 2 to 8.3 bar (29 to 125 psi).

\* Some models use hydraulic pistons.

\*\* For extended life we recommend a maximum of 8 bar (120psig).

ProTech air driven liquid pumps are ratio devices that utilize low pressure compressed air driving a larger diameter piston (area x pressure) which is linearly connected to a smaller hydraulic piston/plunger. Using this ratio principal, a higher hydraulic pressure can be generated.

## AIR DRIVE SECTION

The air drive section of a PM Series pump consists of a light weight piston complete with seals running inside an aluminum barrel. The diameter of the air piston is 80mm.

When compressed air is supplied to the pump the air pushes the air piston down on a compression stroke (forces fluid out of the liquid end).

The PM Series pumps have a single acting air drive with a spring return.

The air drive section of the pump is pre-lubricated at assembly and as such, air-line lubrication is neither required nor recommended.

Air-line filters and regulators are recommended and should be installed to ensure clean dry air is supplied to the pump and that the air drive pressure is not higher than is recommended or required.

The pump's automatic cycling characteristics are enabled by use of an unbalanced, internally pilot operated spool that directs the air through a 3-way cycling sleeve. The operation of the cycling spool is controlled by a pilot pin. The air is exhausted to atmosphere via the provided muffler .

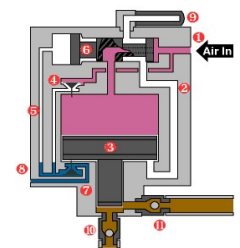
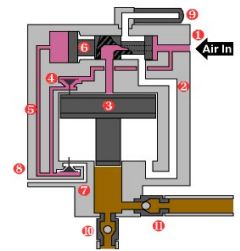

## HYDRAULIC SECTION (WET END)

The hydraulic section of a PROTECH air driven liquid pump consists of 4 main pieces, the hydraulic body, the piston/plunger, the check valves and the main high pressure seal. The hydraulic piston/plunger is directly linked to the air piston and it is housed inside the hydraulic body and its movement up and down creates the liquid flow into and out of the pump through the check valves. The check valves are spring loaded and on the suction stroke the inlet check valve opens to the maximum allowing fluid into the hydraulic body and on the compression stroke the inlet check valve closes and the discharge check valve opens forcing the pumped fluid into the process.

The main high pressure seal is located within the hydraulic body and the piston/plunger seals against this during operation. There are different materials and designs of high pressure seals depending on the fluid being pumped and the maximum pressures of the pump, however the standard seals are suitable for both water and hydraulic fluid use. All wetted materials are of stainless steel and are suitable for water and hydraulic fluid applications in their standard form.

Other materials of construction can be supplied to meet more aggressive services. The standard series of pumps are **NOT** suitable for underground coal mine applications. ProTech do manufacture models of Air Driven Liquid Pumps that are suitable for underground coal mine applications including a range suitable for chemical injection, please enquire to our technical staff.

PROTECH air driven liquid pumps cycle automatically, as the outlet pressure increases the resistance also increases and the cycle rate decreases until the pump stops automatically when the output pressure forces are equal. This is referred to as the stall condition. The pump will restart with a slight drop in the outlet pressure or an increase in the air drive pressure.

Pump performance can be affected by a number of conditions, such as freezing of the exhaust muffler or pilot valves (which is caused by moisture in air lines), inadequate inlet air-line sizes and dirty filters. When operating the pumps on a continuous basis, we recommend you use a maximum cycle rate of 50-60 cycles per minute. This will both increase service intervals and assist in preventing ice forming at the exhaust. An air supply dryer will also assist in reducing icing up.

To obtain best overall performance, do not reduce the indicated port sizes and consult PROTECH for flow conditions not shown in charts.

ProTech offers complete technical and service support for all ProTech Pumps.

## PM Series Dimensions

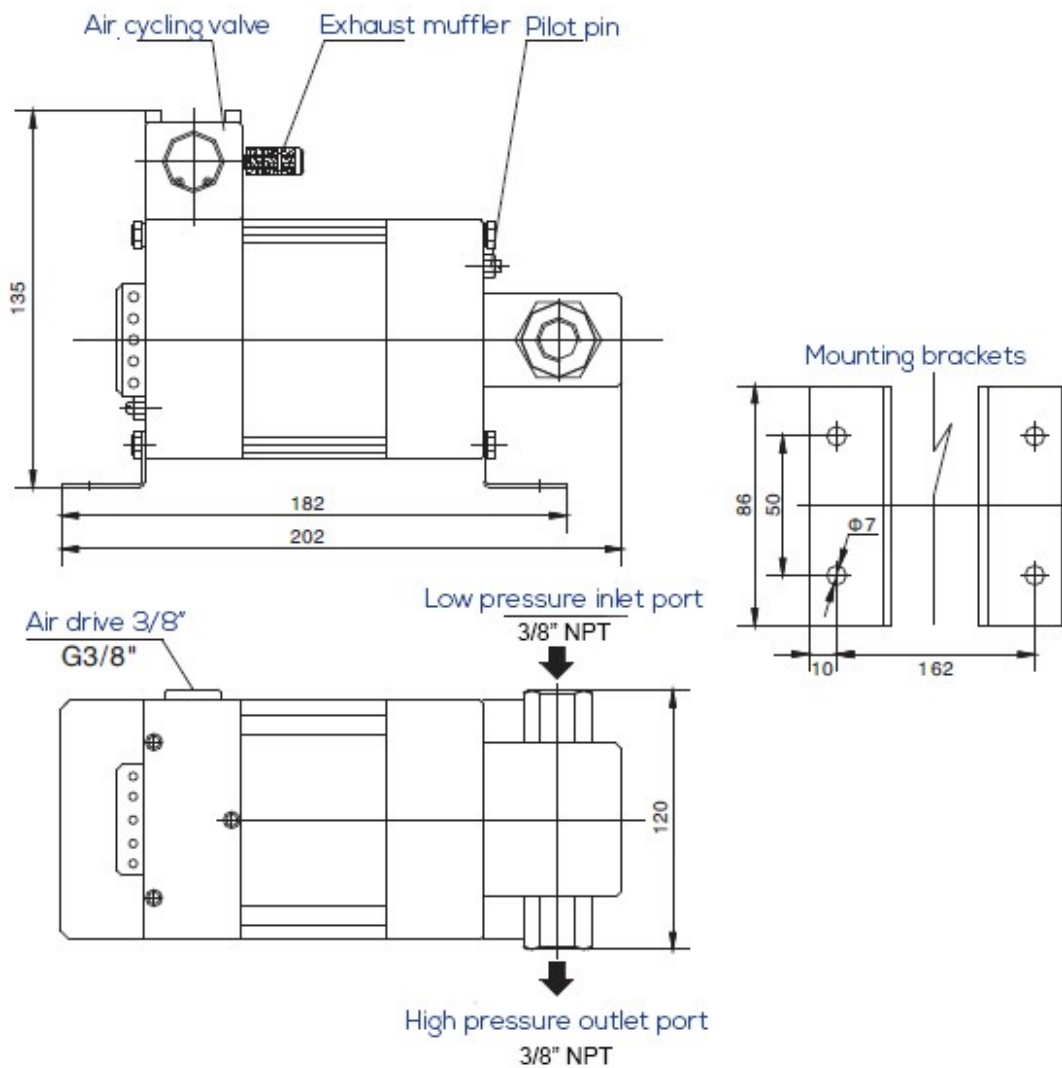

### PM9, PM15, PM22, PM40, PM60, PM100

The ProTech air driven liquid pump can be mounted in any orientation. However, vertically provides the best method and increases seal life and assists in preventing any leaking high pressure fluid entering the air drive

## MODEL SELECTION

It is very important to remember that the performance of any air driven device is very dependent on the air supply conditions. Restrictions in the air supply can be caused by using a too small air compressor or airlines. The FLOW CHARTS shown in this technical sheet are based on good conditions so please do not "Design to the line". Allow for losses and inefficiencies.

The next question is whether you want the pump to stall when an outlet pressure is reached. If so, a simple airline pressure regulator will suffice, but remember, the flow drops off dramatically as the pump reaches a stall condition.

If you require flow at a particular pressure, then you need to read the flow charts carefully and conservatively. If you need the pump to stop at a certain pressure, prior to stall, then an air pilot switch needs to be installed. Please see the ProTech Valves and Accessories for selection.

## AIR SUPPLY

To obtain maximum continuous performance from the PG Series ProTech Air Driven Liquid Pumps we recommend the use of an air compressor with a minimum free air delivery (FAD), **to the pump**, corresponding to the pressure you wish to use. As a guide:

Drive Pressure required at the inlet of the pump	FAD required at the inlet of the pump
4 barg (60 psig)	400 nlpm (20 scfm)
6 barg (90 psig)	600 nlpm (25 scfm)
8 barg (116 psig)	700 nlpm (30 scfm)

# PM Series Flow Graphs

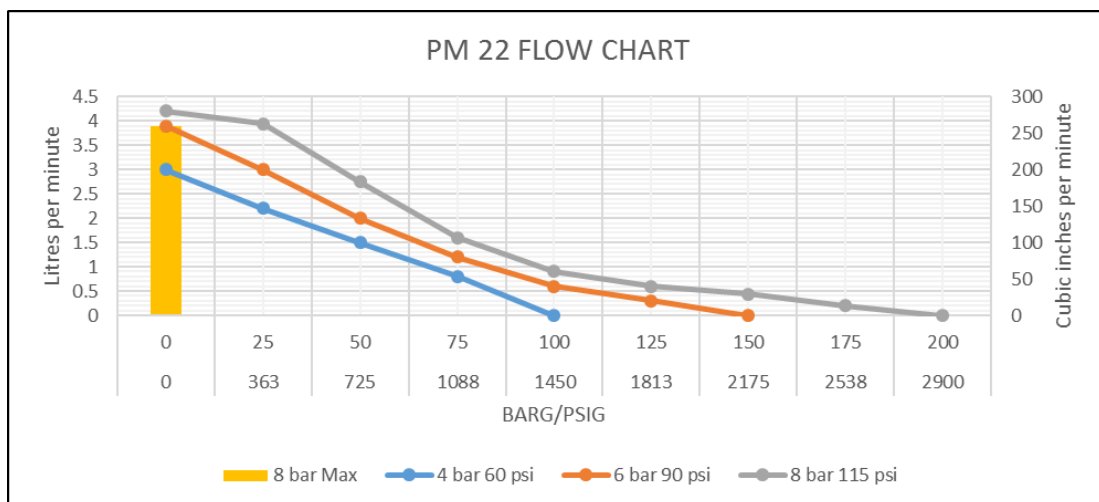
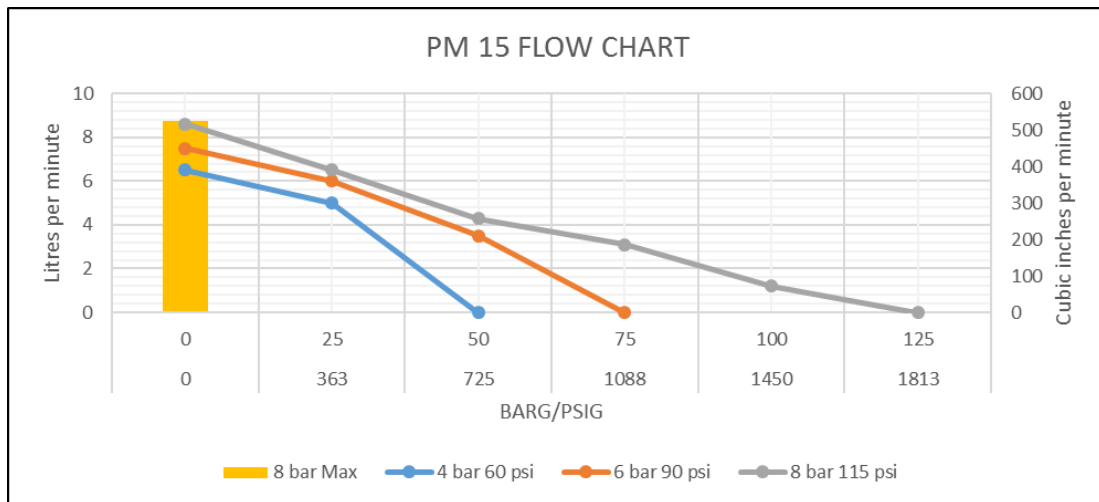
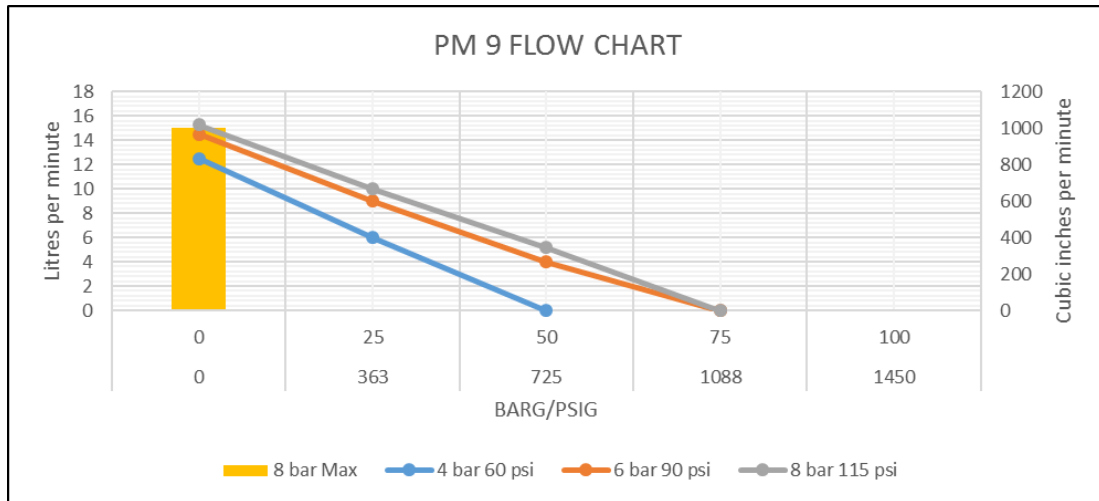

**NOTE:** There are numerous factors affecting the cycle rate, and therefore flow rate of air driven liquid pumps. They can be, but are not limited to, air-compressor performance, air-line restrictions and the icing-up of the exhaust.

# PM Series Flow Graphs

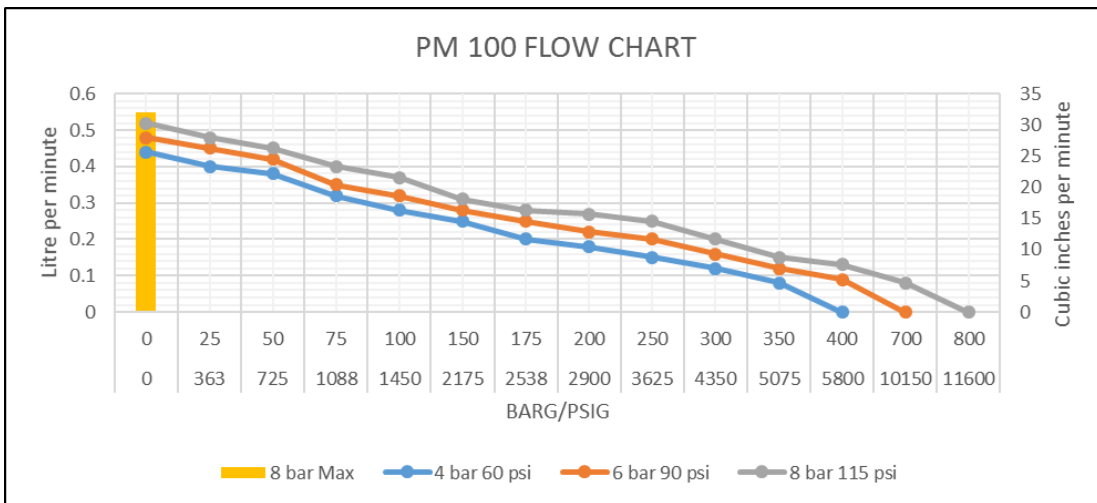
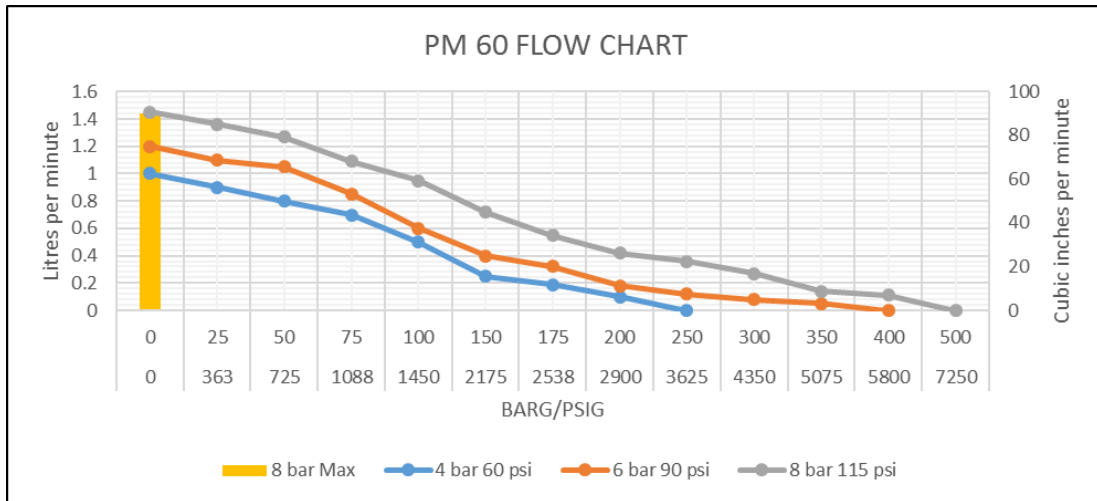
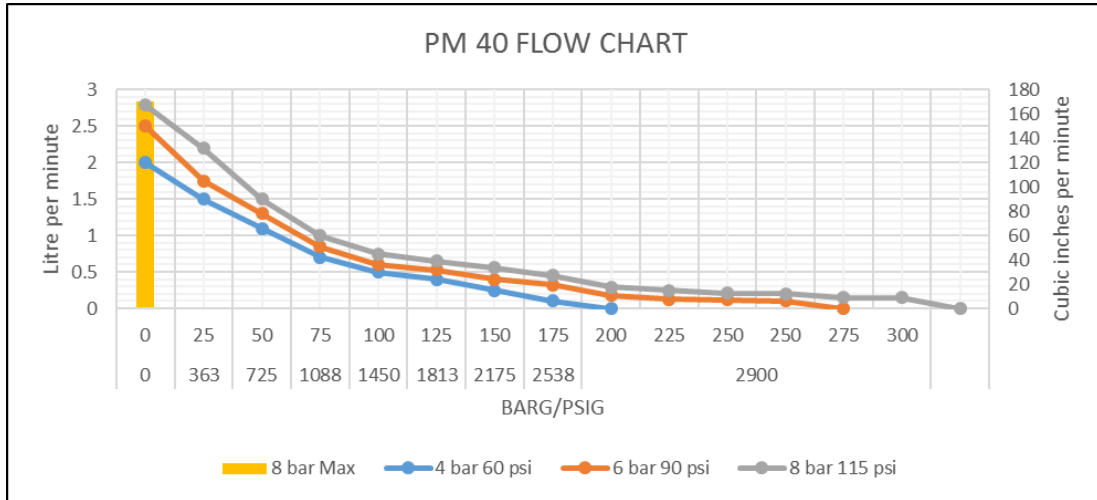

**NOTE:** There are numerous factors affecting the cycle rate, and therefore' flow rate of air driven liquid pumps. They can be, but are not limited to, air-compressor performance, air-line restrictions and the icing-up of the exhaust.



**PROTECH PUMPS**

Air Driven Pumps & Boosters



### PROPAK1 Standard Pressure Test System

Each PROPAK is a self contained Stainless Steel unit which incorporates the following items: Air pressure regulator, air filter, air pressure gauge and on/off speed control valve; ProTech air driven liquid pump up to 3200 barg; Stainless Steel liquid tank with suction strainer or external connection, sight glass and filler/breather cap; outlet pressure gauge; return to tank valve and discharge outlet connection.

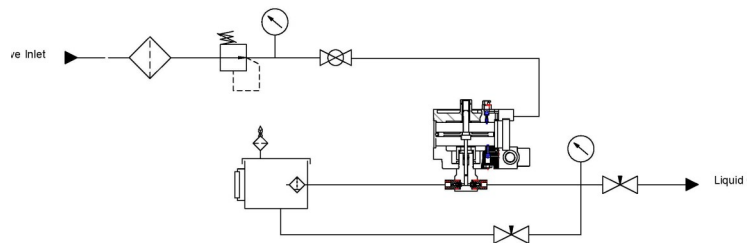

### WARRANTY

ProTech Pumps are fit for purpose providing they are used in accordance with instructions laid out within the related IOM. We warrant that they are free from defects and in the rare occasion that a product is defective, we will repair or replace the product within a period of 12 months from the purchase date. Please read our full warranty conditions on our web site.

**PROTECH PUMPS** has more than 50 years of hydraulic and pneumatic engineering experience in the design and manufacture of pumps and systems for pressure testing and chemical injection. Continuous investment in new machinery and advanced technology keeps PROTECH PUMPS at the forefront of the field. We offer one of the most complete range of Air Driven Pumps & Boosters in the industry measured for:

- > Capability of ultimate pressure, flow or output horsepower.
- > Compatibility with a broad variety of liquids, such as oil, water and chemical applications.

**ProTech Pumps**

Tel:- +61 7 3277 8822  
www.protechpumps.com

Tel:- +1 214 785 8190  
info@protechpumps.com