



ON-PREMISE LAUNDRY



T-50X2 EXPRESS STACK DRYER

Dexter On-Premise Stack Dryer

On-premise laundry solutions you can depend on.

Dexter on-premise dryers are engineered to show up for work in even the harshest laundry environments. Featuring flexible controls and high quality materials, these fast and efficient dryers are designed to help you process laundry faster and more efficiently.

When your business depends on clean laundry, choosing the right equipment is an important decision. Our products will provide you the efficiency, flexibility, performance, and durability you need to be confident in your choice. With lifetime technical support and an industry leading 5 year limited warranty, you can be confident that we will stand behind every dryer you invest in.

Contact your Dexter Authorized Distributor today for more details.

EFFICIENT:

Perforated tumblers, balanced radial airflow, and the right amount of air recirculation provide maximum efficiency.

The anti-wrinkle feature offers an intermittent tumble to keep laundry wrinkle free.

DURABLE:

With heavy-duty bearings in cast iron bearing housings and a fully welded and painted cabinet, Dexter dryers are built to last.

Using proven washer-style technology, welded steel spider assemblies support the tumbler from the rear and eliminate the need for front support rollers.

Formed in tumbler baffles are strong and stable while providing great tumbling action.

RELIABLE:

Our industry leading 5 year warranty covers the trunnion, bearings, and bearing housing.

A 3 year parts warranty covers the rest.

We stand behind every machine you invest in with lifetime technical support.

FLEXIBLE:

Dexter on-premise dryer controls offer adjustable settings and five customizable cycles that provide the power and flexibility needed to fit any laundry.

INSTALLATION:

Stack dryers give you the power of two dryers in a single space.

With a single location for gas, electrical, and venting connections, Dexter stack dryers are easier to install and maintain.

OPTIONS:

Available with stainless steel or galvanized tumblers and white or stainless steel panels.

Gas models, with propane kits available.

Dexter on-premise stack dryers are available in 30lb and 50lb capacities.

EMPLOYEE OWNED | MADE IN THE USA | SINCE 1894

GCLE.COM.AU

PO BOX 3920 ROBINA TC, QLD 4230 AUSTRALIA

1300 309 708

T-50X2 EXPRESS STACK DRYER SPECIFICATIONS

ON-PREMISE LAUNDRY

Capacity:

Dry Weight Capacity	2 x 50 lb	(2 x 22.7 kg)
Cylinder Volume (per tumbler)	15.8 cu ft	(447.4 L)

Speed:

Tumbler Speed	45 RPM	
Motor Speed (per tumbler)	0.75 hp	(0.56 kW)

Airflow (per tumbler):

60 Hz Model	650 cfm	(18.4 M3/min)
-------------	---------	---------------

Dimensions:

Cabinet Height	79 1/4"	(201.3 cm)
Cabinet Width	34 1/2"	(87.6 cm)
Overall Depth	56 3/4"	(144.1 cm)
Door Opening	25 5/8"	(65.1 cm)
Floor to Lower Door Bottom	7"	(17.8 cm)
Floor to Upper Door Bottom	46"	(116.8 cm)
Cylinder Diameter	32 1/2"	(82.6 cm)
Cylinder Depth	33"	(83.8 cm)
Lint Screen Area (per tumbler)	544 sq in	(3510 sq cm)

Weight:

Net Weight	857 lbs	(388.7 kg)
------------	---------	------------

Shipping Information:

Shipping Weight	917 lbs	(415.9 kg)
Shipping Height	84 1/4"	(214 cm)
Shipping Width	36"	(91.4 cm)
Shipping Depth	61 1/2"	(156.2 cm)

Gas Requirements (Gas Models Only):

Gas Supply Connection	1/2"	(12.7 mm)
Natural Gas Supply (Water Column)	5-10"	(12.7 - 25.4 cm)
LP Gas Supply (Water Column)	11 1/2 - 14"	(29.2 - 35.6 cm)

Gas Usage (Gas Models Only):

60Hz Model (per tumbler)	108,000 BTU/hr	(31.7 kW)
--------------------------	----------------	-----------

Electrical Requirements:

Gas Models (per stack dryer):

Model	Volts / Hz / Phase / Wiring	Circuit Breaker / Running Amps / Wire Size
-11	208-240 / 60 / 1 / 2 wire + ground	20 amp / 12 amp / #12

Installation Recommendations:

Minimum Clearance Between Machines	0"	(0 cm)
Minimum Clearance Behind Machines	18"	(45.7 cm)
Make-Up Air Required (per stack dryer)	1.5 sq ft	(1394 sq cm)
Exhaust Size	8"	(20.3 cm)

Agency Approvals*

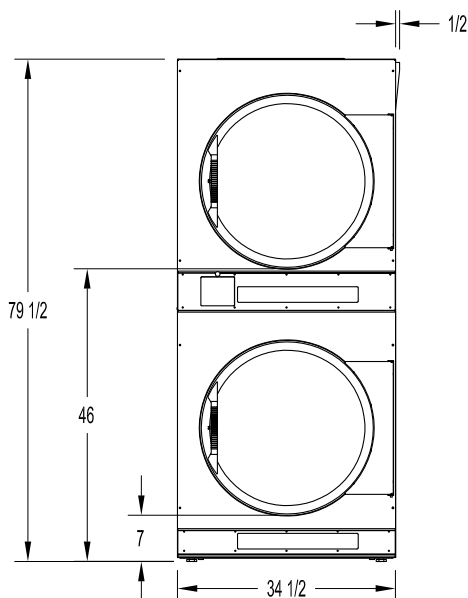

FRONT

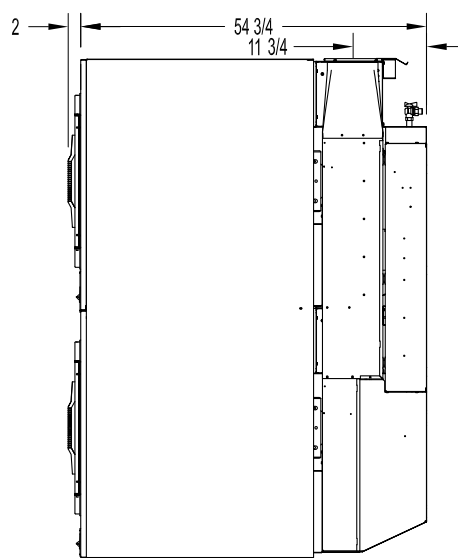

SIDE

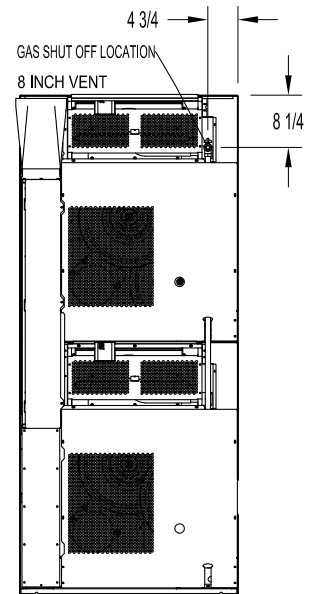

BACK

Due to continuous product improvements specifications are subject to change, please consult the installation manual for the most accurate information.
 *Agency approvals may vary depending on the machine configuration, consult Dexter Laundry or your Dexter Authorized Distributor for details.