

JIALIFT®



www.jialift.com.au

SL15L3/550

Full Electric Walkie Pallet Truck

- 1500kg Capacity, fork width - 550mm
- Easy to operate, power moving and lifting
- Safe, reliable, sustainable and low maintenance

CE

JIALIFT Full Electric Pallet Truck

This electric pallet jack has 1500kg capacity, good for use on a large truck to move items or pallets. It's power moving and lifting. It offers a number of **advantages**:

- It is simple and convenient to disassemble and replace the battery.
- The economic power pallet truck
- Compact and light design
- Low turning radius
- Robust chassis with reinforced forks
- Battery indicator and safety belly button
- The additional suspension ensures the highest stability as well as the longest service life

Standard Equipment:

Also Included in our Offer: Battery and Charger

Warranty: 1 Year refer to the JIALIFT warranty terms and conditions



JIALIFT AUSTRALIA PTY LTD

Call Us: 1300 000 168 Email: sales@jialift.com.au

46-48 Geddes St, Mulgrave VIC 3170 Open at 8:30 am - 5:30 pm, Monday-Friday



www.jialift.com.au

JIALIFT®

MATERIAL HANDLING EQUIPMENT

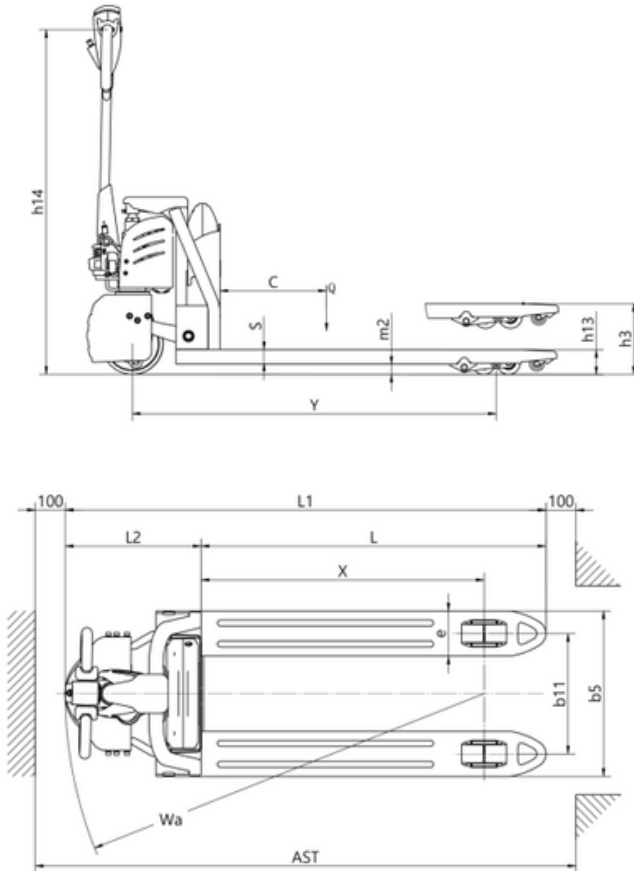

JIALIFT AUSTRALIA PTY LTD

Call Us: 1300 000 168 Email: sales@jialift.com.au

46-48 Geddes St, Mulgrave VIC 3170 Open at 8:30 am - 5:30 pm, Monday-Friday



www.jialift.com.au

Distinguishing mark			
Model designation			SL15L3/550
Drive unit			Electrics
Operator type			Walkie
Rated capacity	Q	kg	1500
Load center distance	c	mm	600
Load distance centre of drive axle to fork	x	mm	944
Wheelbase	y	mm	1243
Weight			
Service weight (include battery)		kg	142
Types, Chassis			
Tyre type Driving wheels/Loading wheels			PU/PU
Tyre size, driving wheels (diameter x width)		mm	210x70
Tyre size, loading wheels (diameter x width)		mm	80x60
Wheels number, driving caster/loading (x=drive wheels)		mm	1x/4
Track width,rear,loading side	b11	mm	400/535
Dimensions			
Lift height	h3	mm	200
Height drawbar in driving position min./max	h14	mm	740/1160
Lowered height	h13	mm	85
Overall length	l1	mm	1603
Length to face of forks	l2	mm	453
Overall width	b1/b2	mm	550
Fork dimensions	s/e/l	mm	50/150/1150
Outside width of the forks	b5	mm	550
Ground clearance, center of wheelbase	m2	mm	35
Aisle width for pallets 1000 × 1200 crossways	Ast	mm	1804
Aisle width for pallets 800 × 1200 lengthways	Ast	mm	1854
Turning radius	Wa	mm	1398
Performance data			
Travel speed, laden/ unladen		km/ h	4.2/4.5
Max. gradeability, laden/unladen		%	5/10
Service brake type			Electromagnetic
Electric-engine			
Drive motor rating		kW	0.75
Lift motor rating		kW	0.8
Battery voltage/nominal capacity	V/ Ah	24/20 24/30 24/40	
Battery weight	kg	6 10.2 13.2	
Addition data			
Type of drive unit			DC
Sound pressure level at the driver' s ear		dB(A)	70
Steering Type			Manual Steering System



JIALIFT AUSTRALIA PTY LTD

Call Us: 1300 000 168 Email: sales@jialift.com.au

46-48 Geddes St, Mulgrave VIC 3170 Open at 8:30 am - 5:30 pm, Monday-Friday

www.jialift.com.au