



www.bandsaw.com.tw



鎂佳機械工業股份有限公司 MEGA MACHINE CO.,LTD.

台灣 · 41154 台中市太平區工業路180號
No.180, Industrial Road, Tai-ping District, Taichung City, 41154, Taiwan R. O. C.
www.bandsaw.com.tw
Tel:+886-4-22712877(Rep.) Fax: +886-4-22715016
E-Mail: sales@bandsaw.com.tw

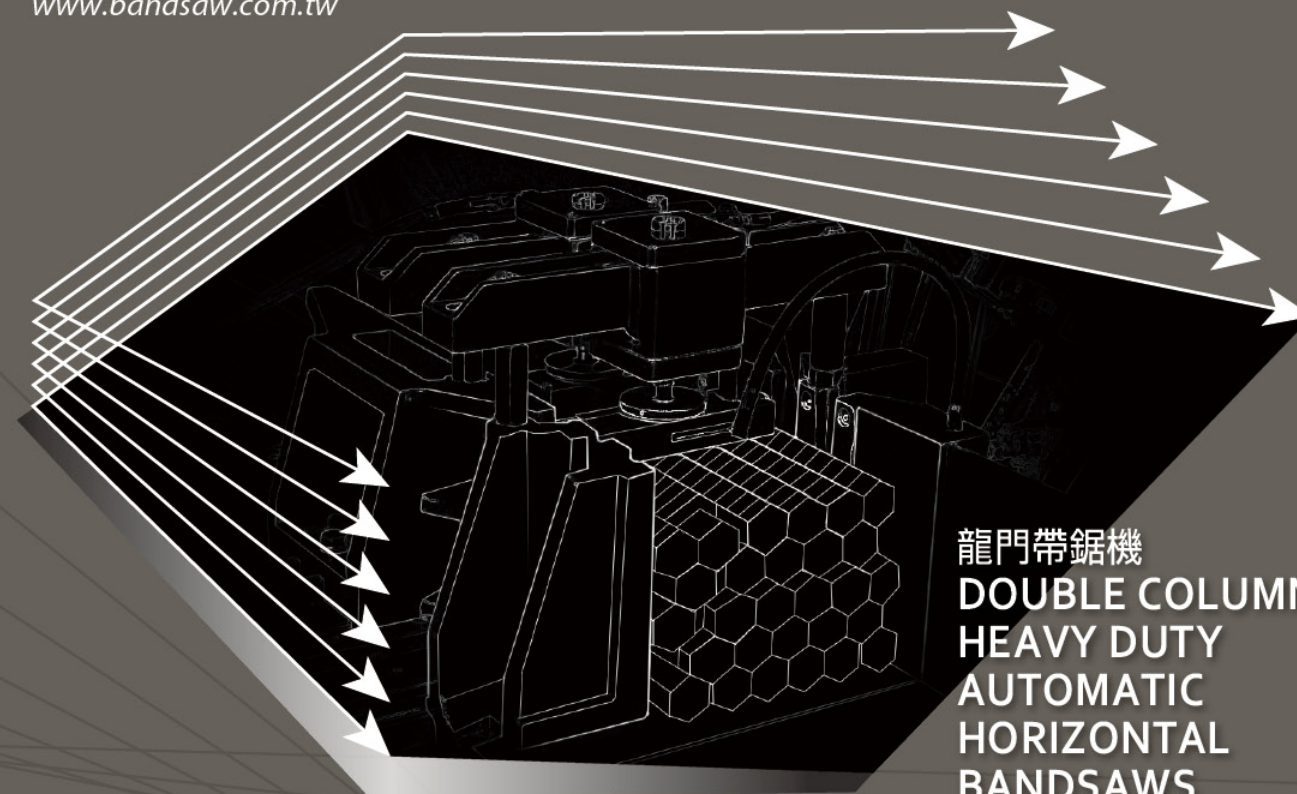

龍門帶鋸機 DOUBLE COLUMN HEAVY DUTY AUTOMATIC HORIZONTAL BANDSAWS

- H-S (伺服進刀 Servo Feedrate)
- H-GA (數值控制 Numeric Control)
- H-A (全自動 Full-Auto)
- H (半自動 Semi-Auto)



Official Website

2021.03
886-4-2266-9809

Keep Improving & Quality Oriented - Skillful engineering and imaginative design give every MEGA Band Saw Machine exceptional cutting capacity.
不斷創新與精進&嚴格執行品質要求 - 以操作者為出發點的設計,並追求完美的品質

H-360GA 全自動油壓龍門式帶鋸機

DOUBLE COLUMN HEAVY DUTY AUTOMATIC HORIZONTAL BANDSAW

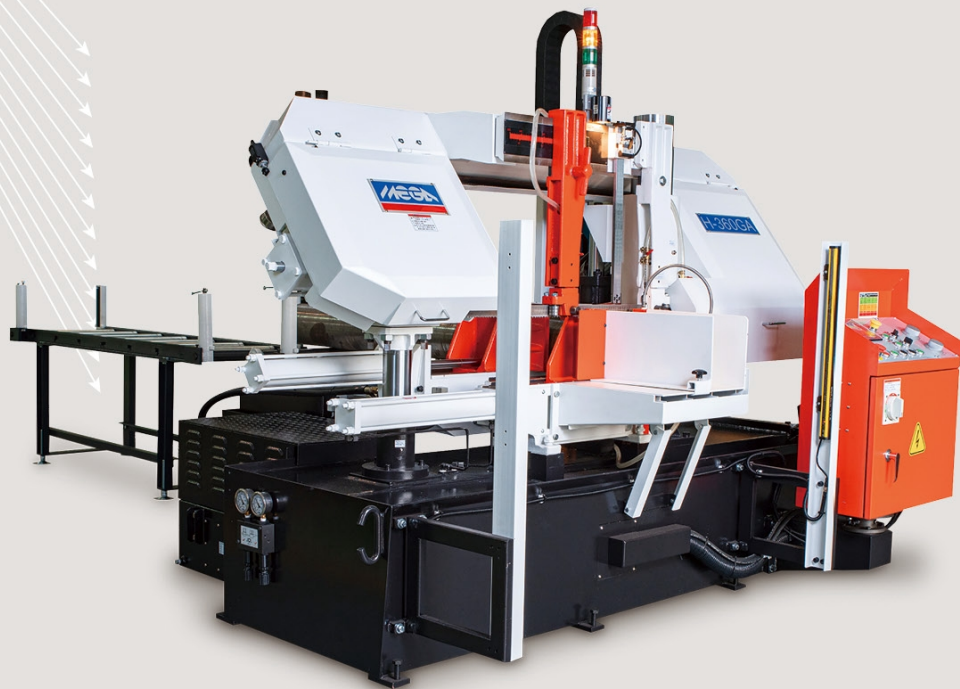

規格表 Specifications

規格 / 機型 SPEC. / MODEL	H-360GA	
鋸切能力 Cutting Capacity	mm	● 400 ■ 400W X 400H
	in	● 15.75 ■ 15.75W X 15.75H
整把切削 Bundle Cutting	mm	最小 Min 198W X 130H / 最大 Max 340W X 180H
	in	最小 Min 7.8W X 5.1H / 最大 Max 13.4W X 7.1H
鋸帶尺寸 Blade Size	mm	41W X 1.3t X 4880L
	in	1.6W X 0.05t X 192.1L
鋸帶速度 Blade Speed	M/min	無段變速 Variable Speed 20-120
	F/min	無段變速 Variable Speed 65-390
馬達 Motor Output	HP	鋸帶 Blade 7.5, 油壓 Hyd.2, 冷卻 Coolant 1 / 8
	KW	鋸帶 Blade 5.6, 油壓 Hyd.1.5, 冷卻 Coolant 0.1
封箱尺寸 (L X W X H) Shipping Volume	mm	2640 X 2210 X 1910
	ft	8.66 X 7.25 X 6.27
淨重 / 毛重 N.W. / G.W.	kg	2729 / 2959
	lb	6004 / 6510

標準配備 Standard Equipment

工具箱 Tools with tool box	1 只 set
2M(7 ft.)長滾輪台 Long roller table with vertical roller guides	1 台 set
清屑鋼刷輪 Band-cleaning wire brush	1 件 pc
鋸帶 Bandsaw blade	1 條 pc
油壓張力 Hydraulic blade tension	1 組 set
自動清屑裝置 Automatic chip conveyor	1 組 set
操作手冊與零件清單 Instruction manual and parts list	1 本 copy
LED 工作燈 LED work lamp	1 式 set
直截式馬達搭配減速機鋸帶速度 20-120 米 / 分鐘 High efficient gear box reducer for speed 20-120m/min	1 式 set

選擇配備 Optional Equipment

- 夾鉗壓力可調 Variable vise pressure system.
- 鋸切速率調整用增幅閥
Amplifying valve for auto-adjusting cutting feed-rate.
- 防傾斜 Cutting deviation detecting system.
- 深度切削 Cutting depth control.
- 光閘 Safety light curtain in front of machine.
- 三色燈 3-Color LED alarm signal lamp and buzzer.

全自動油壓龍門式帶鋸機

DOUBLE COLUMN HEAVY DUTY AUTOMATIC HORIZONTAL BANDSAW

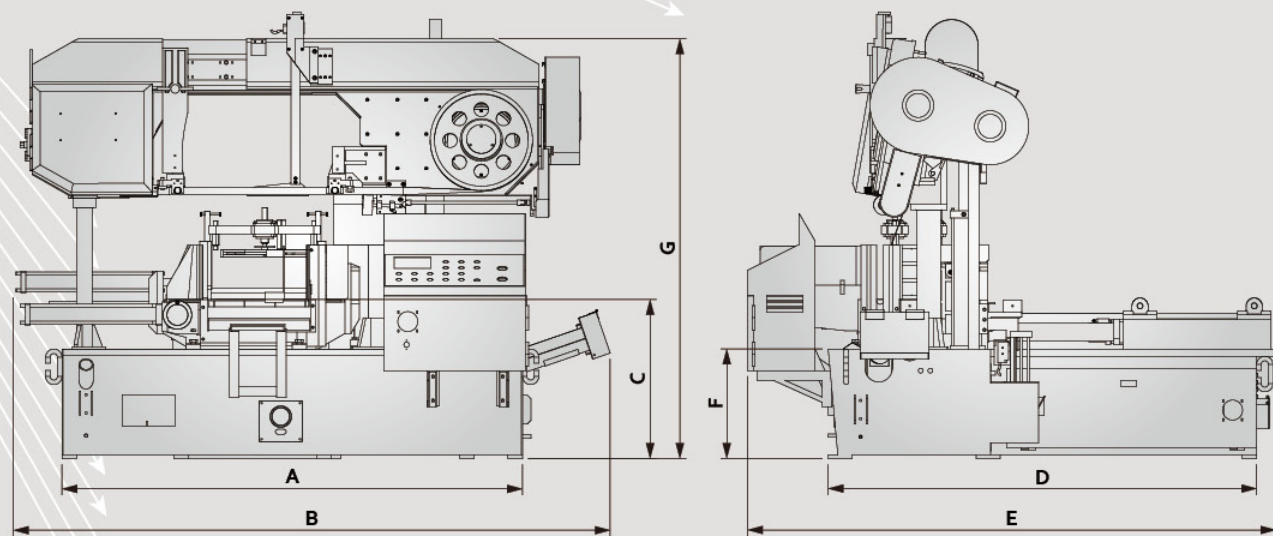

機型 / 規格 MODEL / SPEC.	單位 UNIT	A	B	C	D	E	F	G
H-360GA	mm	2320	2744	718	1925	2330	472	1890
	inch	91.3	108	28.3	75.8	91.7	18.6	74.4
H-330A/GA	mm	1650	2261	709	1718	2111	524	1730
	inch	65.0	89.0	27.9	67.6	83.1	20.6	68.1
H-400A/GA	mm	1915	2471	662	1782	2197	456	1857
	inch	75.4	97.3	26.1	70.2	86.5	18.0	73.1
H-460A/GA	mm	2320	2796	749	2030	2560	500	2005
	inch	91.3	110.1	29.5	79.9	100.8	19.7	78.9
H-550A/GA	mm	2322	3134	710	2014	2535	460	2186
	inch	91.4	123.4	28.0	79.3	99.8	18.1	86.1
H-600A/GA	mm	2900	3427	622	2050	2580	342	2414
	inch	114.2	134.9	24.5	80.7	101.6	13.5	95.0
H-700A/GA	mm	2900	3866	608	2086	2400	356	2386
	inch	114.2	152.2	23.9	82.1	94.5	14.0	93.9

半自動油壓龍門式帶鋸機

DOUBLE COLUMN HEAVY DUTY SEMI-AUTOMATIC HORIZONTAL BANDSAWS

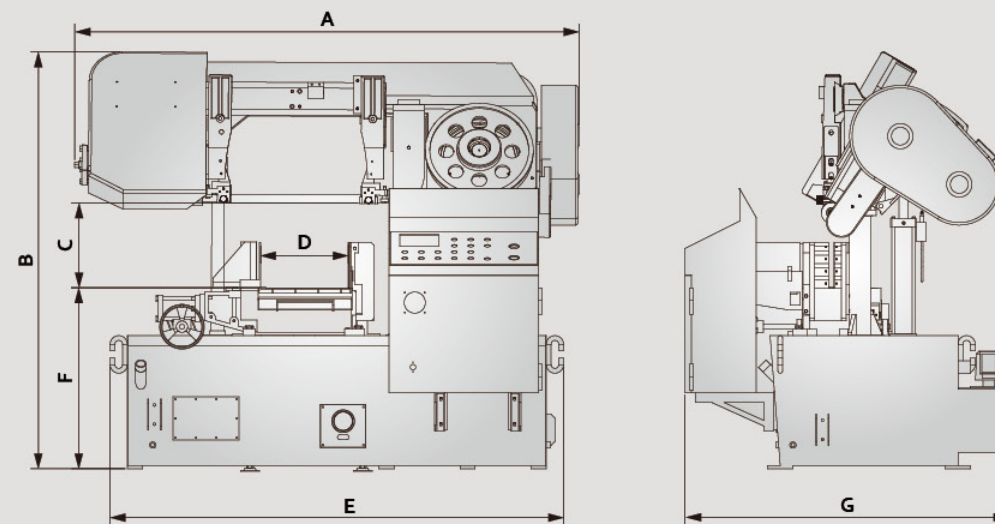

機型 / 規格 MODEL / SPEC.	單位 UNIT	A	B	C	D	E	F	G
H-330	mm	2150	1680	350	345	1650	700	742
	inch	84.6	66.1	13.8	13.6	65.0	27.6	29.2
H-400	mm	2267	1810	420	425	1915	707	650
	inch	89.3	71.3	16.5	16.7	75.4	27.8	25.6
H-460	mm	2720	1905	480	480	2000	700	900
	inch	107.1	75.0	18.9	18.9	78.7	27.6	35.4
H-550	mm	2850	2186	600	640	2322	700	1170
	inch	112.2	86.1	23.6	25.2	91.4	27.6	46.1
H-600	mm	3550	2550	625	650	2900	600	2300
	inch	139.8	100.4	24.6	25.6	114.2	23.6	90.6
H-700	mm	3803	2370	800	720	2900	608	1070
	inch	149.7	93.3	31.5	28.3	114.2	23.9	42.1