

# AYA K6

## TECHNICAL INFORMATION

- The ultra-compact in its category: 362x413x869 (h) mm
- Two direct motors to ensure safe circulation of the chocolate
- Designed with attention to details, it has a tank capacity of 6.5 kg
- Reduced consumption: 1 kW at full capacity, 300 W in night mode (50/60Hz 230V)
- Available in single and double versions
- Total weight machine 38 kg



### THE CHOCOLATE FOUNTAIN

The AYA K6 chocolate fountain is an ideal product for ice cream shop, pastry or chocolate shop. It gives a decisive touch of class and allows you to include an important product in your everyday menu offering. The machine is equipped with two motors, one for the mixer and the second for the auger.

The machine's night mode allows you to keep the chocolate melted in the tank ready for quick restart the following morning and without blockages, reducing absorption during the period of inactivity.

Thanks to the removable stainless steel auger it is possible to quickly and completely clean the chocolate circuit.

Installing the machine in the counter is recommended to increase the aesthetic effect. Bilait can offer tailor-made solutions for you.

The fountains are available three types:

- Classic (included in the purchase price)
- Lieve (Additional)
- Fanstia (Additional)

The touch of class

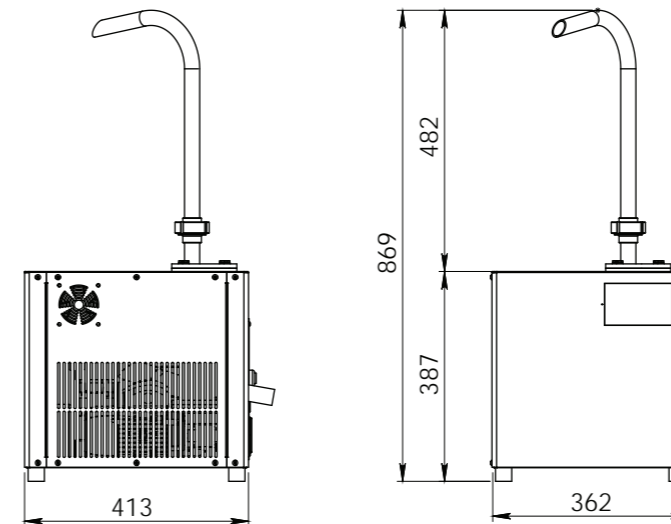

#### Included:

- Classic fountain
- Removable stainless steel screw
- Stop & Go Flow Pedal
- Multifunction program

#### Accessories:

- Supply of built-in cabinet Built-in kits
- Gilding of the external parts
- Two additional types of fountain Fanstia & Lieve

#### CHARACTERISTICS COMPARED

AYA K6: 5 stars

Rating similar products: 3.7 stars

Production capacity

Functionality

Technology

Affordability



dessert projects & equipment supply

www.italiangelato.com.au



Italian Gelato Concepts Pty Limited

Unit 1, 37 Mortimer Road  
Acacia Ridge Qld 4110

Bris Office: +61 (0) 7 3162 7724

Syd Office +61 (0) 2 8311 9701

Email: [info@italiangelato.com.au](mailto:info@italiangelato.com.au)

[www.italiangelato.com.au](http://www.italiangelato.com.au)



BILAIT S.R.L

VIA DELLA FERROVIA 60. 25085. GAVARDO (BRESCIA). ITALIA

+39 0365 224424. [Info@bilait.it](mailto:Info@bilait.it). [www.bilait.it](http://www.bilait.it)

P. VA/Vat number: 03878990989