



Pratt Burnerd International
Guide to Workholding

Support & Service



Buy Spare Parts

You can buy Colchester, Harrison and Clausing spare parts from us, our experts are there to help you identify the correct replacement part and ensure prompt delivery every time.



Reliable Servicing

Our factory trained engineering team are always available to support your machine tool, either through our dedicated help-desk or out in the field.



Machine Tool Finance

Colchester Machine Tool Solutions offer finance options to support your machine tool purchase.



Valuable Training

Whether it's when your new machine arrives, or more intensive courses to ensure that you make the most of your machine tool, our applications specialists are there to support you.



Delivery & Installation

Our service teams are on-hand to effectively deliver, install and commission your machine tool exactly to your satisfaction.



Preventative Maintenance

We work closely with you on a range of preventative maintenance contracts ensuring your assets are utilised fully, whether for one machine or a workshop of our machine tools.

FOR FURTHER INFORMATION OR TO REQUEST A DEMONSTRATION
PLEASE CONTACT OUR SALES TEAM 02 9674 4738 | sales@colchestermachines.au | colchestermachines.au

27 Foundry Road | Seven Hills | NSW 2147



Certificate No. QEC20541



The home of Pratt Burnerd International and Dickson products

Pratt Burnerd International have a worldwide reputation for the manufacture of manual and power chucking systems for a wide range of industrial and training applications. This is also the home of the original and world renowned Dickson Toolpost.

Contents

• Super Precision Chucks	4
• Standard Accuracy Chucks	6
• Griptru Scroll Chucks 3 & 6 Jaw	8
• Setrite Scroll Chucks	10
• Lever Operated Scroll Chucks	12
• Super Thin Round Chucks	13
• Metric 4 Jaw Independent Chucks	14
• Large Scroll Chucks - Medium & Heavy duty	16
• Large 4 Jaw Independent Chucks - Medium & Heavy Duty	17
• Gripfast Power Chucks	18
• Self-contained Pneumatic Power Chucks	20
• Gripsafe - Gripmeter	21
• Front Hand Wheel Collet Chucks 5C and 16C	22
• Quick Change 5C Collet Chuck	24
• Air Power Front Mount Collet Chucks	24
• Spindle Conversion Adaptors	25
• Chuck Lubricant	25
• Dickson Quick Change Toolposts and Toolholders	26
• Standard Spindle Nose Data	28



Dickson Quick Change Toolposts and Toolholders

The original, world renowned Dickson Toolpost

The world renowned Dickson quick change system was developed as a major advance from the conventional four way toolpost and this simple, robust design uses hardened and ground components to give high levels of accuracy and repeatability.

A versatile range of supplied toolholders can be interchanged in seconds, providing a flexible approach to machining, giving proven significant set-up time savings.

Centre height adjustment is achieved in seconds with a simple knurled nut, eliminating the need for packing pieces.

Dickson Quick change toolpost kits can be supplied with standard toolholders and V' / Boring bar toolholders as required.

Additional Morse Taper, Plain Bore, Parting Off and Extended toolholders are also available as options.

The stud assembly which attaches the Toolpost onto the machine Top Slide are also available.

- Toolpost body has capacity for up to 3 Toolholders
- Toolholder change over time can be reduced significantly using the preset holders
- Supplied in a range of 4 sizes with derivatives, to suit most lathe requirements
- Precision clamping surfaces and guide grooves allow accurate toolholder location
- Straightforward single quick release mechanism for manual indexing of turret
- Simple toolholder height adjustment
- Manufactured with all case hardened and precision ground components
- Heavy duty CNC versions available



	A/mm	B/mm	C/mm	D/mm	E/mm	F/mm	G/mm	H/mm	J/mm	K/mm	L/mm	M/mm	N/mm	P/mm
S1	31 / 53	20	16	22.5 / 44	16	23 / 42	50	MT1	73	63.5	31.75	6.3	19	123
S2	34.5 / 51.5	20	25	26 / 47	19	28 / 50	65	MT2	97.4	71.4	44.45	7.9	25.4	158
S2T	41.5 / 59	25	25	24.5 / 42	19	32.5 / 52	70	MT2	106	76.2	44.45	7.9	25.4	167
S3	52 / 76	32	25	29 / 58.5	25	36 / 61	85	MT3	125.7	95.2	50.8	9.5	25.4	200
S4	57.5 / 89	32	32	40.5 / 75	25	40 / 79	100.6	MT4	149	120.5	63.5	12.7	38.1	241

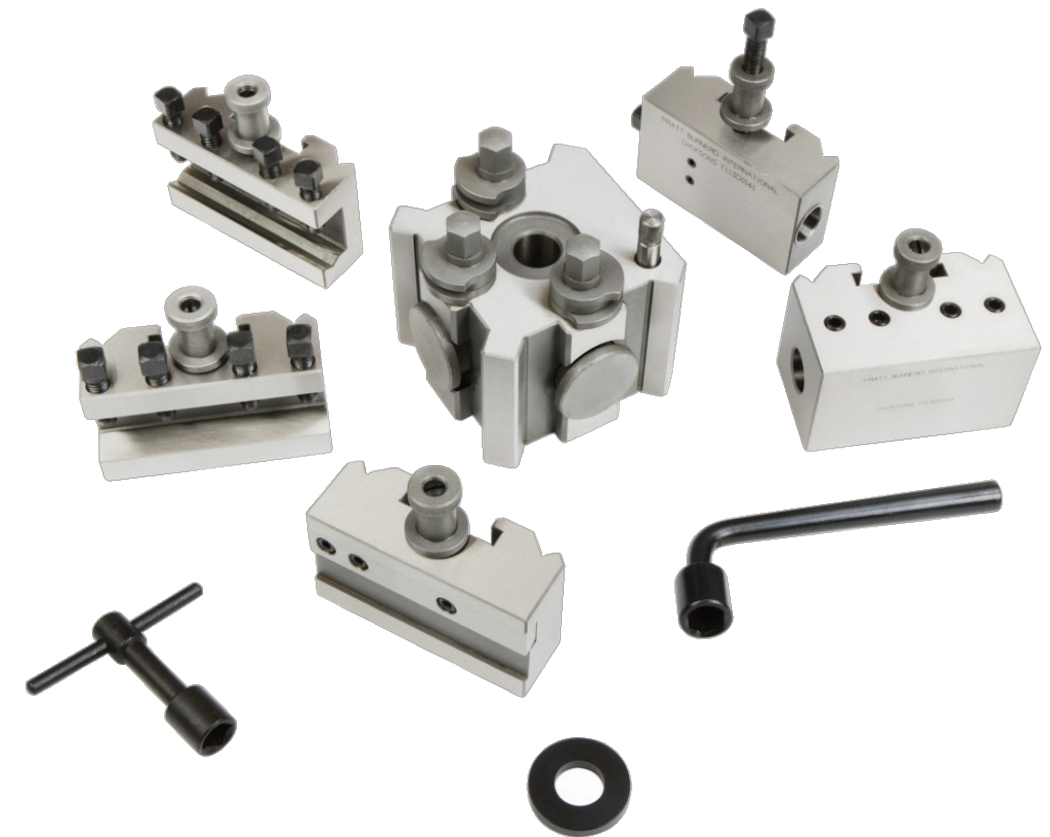
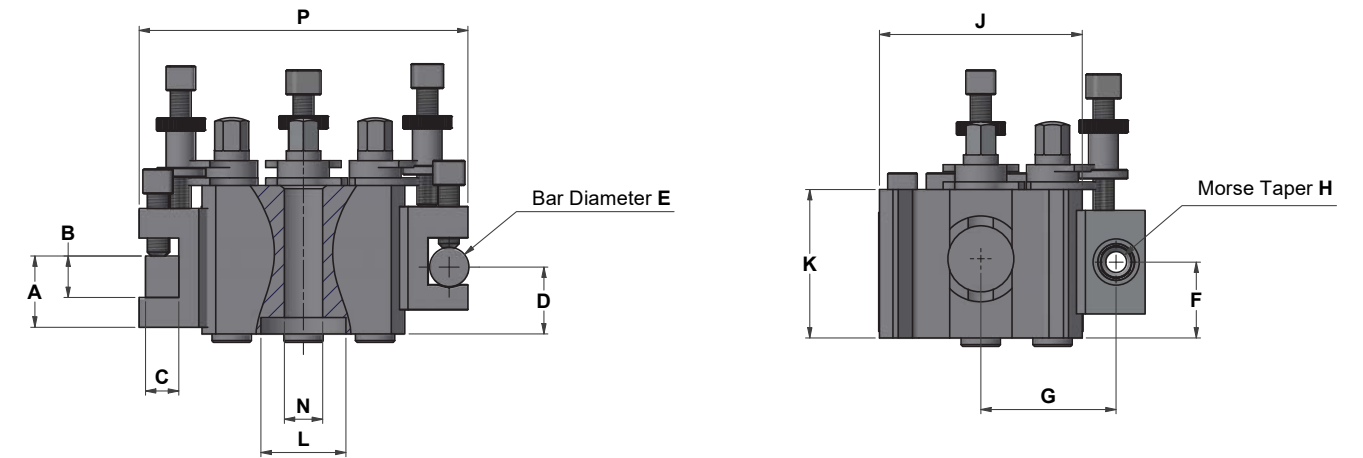

FOR FURTHER INFORMATION OR TO REQUEST A DEMONSTRATION
PLEASE CONTACT OUR SALES TEAM 02 9674 4738 | sales@colchestermachines | colchestermachines.au

27 Foundry Road | Seven Hills | NSW 2147



Certificate No. QEC20541