

# **BM-V-SDB, BM-V-SD, BM-V-S, BM-V-SB**

**INCLUDING: OPERATION, INSTRUCTION, INSTALLATION, MAINTENANCE AND PARTSBOOK**

**IMPORTANT: READ THIS MANUAL CAREFULLY BEFORE INSTALLING, OPERATING OR SERVICING THIS TOOL.**

## **CARCASS SPLITTING SAW**

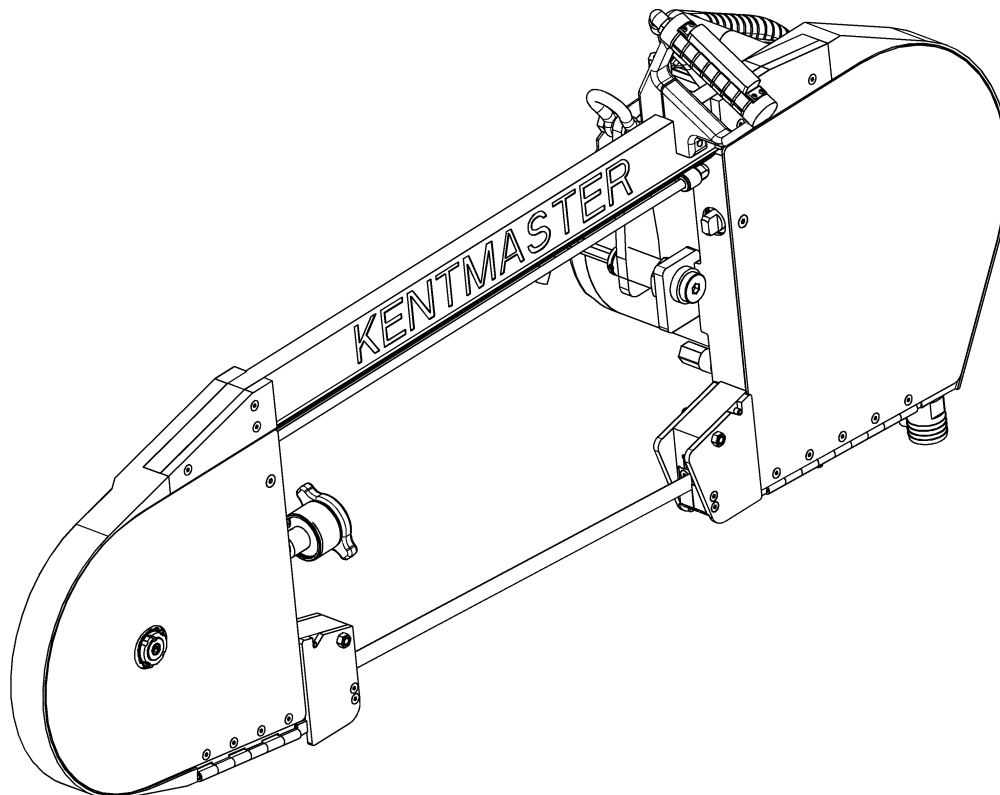
### **TOOL DATA**

MODEL: BANDMASTER BM-V-SDB  
 ASSEMBLY NO. 1730000  
 TYPE: ELECTRICAL OPERATED  
 NET WEIGHT: 166 LB (75.5 KG)  
 MOTOR HORSEPOWER: 2HP / 3HP

MODEL: BANDMASTER BM-V-S  
 ASSEMBLY NO. 1708000  
 TYPE: ELECTRICAL OPERATED  
 NET WEIGHT: 180 LB (82 KG)  
 MOTOR HORSEPOWER: 3HP / 5HP

MODEL: BANDMASTER BM-V-SD  
 ASSEMBLY NO. 1708100  
 TYPE: ELECTRICAL OPERATED  
 NET WEIGHT: 170 LB (77.3 KG)  
 MOTOR HORSEPOWER: 2HP / 3HP

MODEL: BANDMASTER BM-V-SB  
 ASSEMBLY NO. 1708050  
 TYPE: ELECTRICAL OPERATED  
 NET WEIGHT: 200 LB (91 KG)  
 MOTOR HORSEPOWER: 3HP / 5HP



VIBRATION: LESS THAN (<) 123 dB < 1.41m/s<sup>2</sup>  
 NOISE: LESS THAN 81dB

**⚠ NOTICE**

= Hazards or unsafe practices which could result in severe personal injury, death or substantial property damage.

= Hazards or unsafe practices which could result in minor personal injury, product or property damage.

= Important installation, operation or maintenance information.

## **OPERATING AND SAFETY INSTRUCTIONS**

**⚠ WARNING**

DO NOT OPERATE THIS TOOL UNTIL YOU HAVE READ AND UNDERSTOOD THE SAFETY INSTRUCTIONS AND OPERATING MANUALS.

**⚠ WARNING**

DO NOT OPERATE THIS TOOL UNTIL YOU HAVE RECEIVED TRAINING IN THE HANDLING, OPERATION AND USE OF THIS TOOL.

**⚠ WARNING**

STOP USING A MALFUNCTIONING OR DEFECTIVE TOOL IMMEDIATELY. REPORT ANY PROBLEMS OR DEFECTS TO YOUR SUPERVISOR FOR REMOVAL OF THE TOOL FROM SERVICE.

**⚠ WARNING**

DO NOT ATTEMPT TO REPAIR THE TOOL YOURSELF.

**⚠ WARNING**

DO NOT ALLOW UNAUTHORIZED PERSONS TO USE TOOL.

**⚠ WARNING**

REMOVE AND DISCONNECT POWER FROM THE TOOL WHEN TOOL IS LEFT UNATTENDED OR IS NOT IN USE.

**⚠ WARNING**

NEVER TIE DOWN, BYPASS, ALTER OR MODIFY THE ACTIVATING SWITCHES OR TRIGGERS OF THIS TOOL.

**⚠ WARNING**

NEVER MAKE ALTERATIONS OR MODIFICATIONS TO THIS TOOL.

**⚠ WARNING**

BE CONSTANTLY AWARE AND ALERT FOR UNSAFE CONDITIONS AND REPORT THEM IMMEDIATELY TO YOUR SUPERVISOR.

**⚠ WARNING**

NEVER PLACE YOUR HAND OR ANY PART OF YOUR BODY IN THE CUTTING PATH OF THE TOOL.

**⚠ WARNING**

NEVER ALLOW ANYONE ELSE TO PLACE THEIR HANDS OR ANY PART OF THEIR BODY IN THE CUTTING PATH OF THE TOOL.

**⚠ WARNING**

DO NOT ACTIVATE CONTROL SWITCHES OR TRIGGERS OF THIS TOOL UNLESS YOU INTEND TO TEST OR OPERATE THIS TOOL.

**⚠ WARNING**

DO NOT USE THIS TOOL FOR ANY PURPOSE OTHER THAN IT'S INTENDED PURPOSE.

**⚠ CAUTION**

WHEN OPERATING THIS TOOL WEAR THE PROTECTIVE GEAR AND SAFETY EQUIPMENT SUPPLIED TO YOU.

**⚠ WARNING**

THE NOISE EMISSION (SOUND PRESSURE LEVEL) AT THE WORKSTATION MAY EXCEED 80 dB (A). EAR AND SOUND PROTECTION GEAR IS REQUIRED.  
VIBRATION: LESS THAN (<) 123 dB < 1.41m/s<sup>2</sup>

NOISE: LESS THAN 81dB

**OPERATING INSTRUCTIONS****⚠ WARNING ONLY TRAINED PERSONNEL ARE TO OPERATE THIS TOOL.**

1. TO ENSURE TOOL IS OPERATING PROPERLY, PERFORM FOLLOWING STEPS AT START OF EACH SHIFT:
  - MAKE SURE TOOL MOVES UP AND DOWN FREELY WHILE HANGING FROM BALANCER OVERHEAD.
  - WITH POWER TO TOOL TURNED ON, TEST TRIGGER FOR PROPER OPERATION.
  - DEPRESS EACH TRIGGER SEPARATELY. TOOL SHOULD NOT ACTIVATE. DEPRESS BOTH TRIGGERS. TOOL SHOULD ACTIVATE.
  - IF TOOL HAS "ANTI-TIE DOWN" OPTION, BOTH TRIGGERS MUST BE DEPRESSED SIMULTANEOUSLY FOR TOOL TO ACTIVATE.
2. TO PERFORM WORK, HOLD TOOL FIRMLY AT BOTH HANDLES. SQUEEZE TRIGGERS TO ACTIVATE TOOL.
3. START CUT WITH SAW NOSE POINTED UP AT AN ANGLE.
4. LEVEL SAW TO HORIZONTAL POSITION IN LOIN AREA.
5. POINT NOSE OF SAW AT DOWNWARD ANGLE IN CHUCK AND NECK AREA.
6. A BEGINNING SPLITTER CAN MARK BACKFAT OF BEEF WITH A KNIFE TO HELP SAW DOWN CENTER OF BACKBONE AND UNTIL OPERATOR IS FAMILIAR WITH SPLITTING PROCEDURE.
7. DO NOT EXERT EXCESSIVE PRESSURE. ALLOW TIME FOR THE TOOL TO CUT.
8. PUSH SAW FORWARD SO THAT GUARDS, ITEMS 1 AND 2 FIGURE 1, RIDE AGAINST BEEF. THIS HELPS STEADY SAW IN CUT AND HELPS ELIMINATE BLADE JUMPING AND CHATTERING.

**MAINTENANCE****⚠ WARNING ONLY TRAINED AND QUALIFIED PERSONNEL ARE TO PERFORM MAINTENANCE AND SERVICE TO THIS TOOL.**

1. TOOL REQUIRES GREASING AFTER 40 HOURS OF OPERATION. GREASE USING KENTMASTER GREASE (PART NO. 7903070).

**BLADE REMOVAL AND CLEANING.****⚠ WARNING****ALWAYS DISCONNECT POWER SUPPLY FROM TOOL BEFORE INSTALLING OR REMOVING BLADE FROM TOOL.****⚠ WARNING****ALWAYS WEAR WIRE MESH GLOVES WHEN INSTALLING OR REMOVING BLADE FROM TOOL.**

1. REMOVE PAPER WRAPPER FROM BLADE.
2. OPEN COVERS, FIGURE 1, ITEMS 1,2, 3 AND 4.
3. INSTALL TORQUE WRENCH, ITEM 5, INTO SCREW, FIGURE 1, ITEM 6, AND TURN COUNTER-CLOCKWISE (CCW). THIS ALLOWS TAKE-UP WHEEL AND SLIDE, ITEMS 7 AND 8, TO RETRACT.
4. SLIDE TAKE-UP WHEEL TO RIGHT.
5. HOLD BLADE, WITH TEETH FACING AWAY FROM YOU, AND INSTALL INTO SLOT OF BEAM, CONTINUING AROUND AND OVER THE TAKE-UP AND DRIVE WHEELS.
6. TURN TORQUE WRENCH CLOCKWISE (CW) TO ELIMINATE BLADE SLACK AND TIGHTEN TAKE-UP WHEEL AGAINST BLADE (TORQUE WRENCH IS PRESET AT FACTORY AND WILL SLIP AFTER PLACING PROPER TENSION ON BLADE).
7. TWIST BLADE 90° AT BLADE GUARDS AND INSERT BLADE INTO SLOTS WITH TEETH FACING DOWNWARD.
8. TURN DRIVE WHEEL, ITEM 9, SLOWLY BY HAND, TO CHECK TRACKING OF BLADE ON WHEELS.
9. RETORQUE AGAIN UNTIL TORQUE WRENCH SLIPS.

**AT END OF EACH SHIFT:**

1. REMOVE SAW BLADE.
2. IF USING BLADE AGAIN, WASH BLADE WITH HOT WATER TO REMOVE FAT, MEAT AND BONE PARTICLES.
3. DRY AND APPLY A COAT OF MINERAL OIL TO ENTIRE SURFACE OF BLADE TO AVOID OXIDATION.

## CLEANING AND STERILIZING SAW

### AT END OF EACH SHIFT:

1. REMOVE SAW BLADE.
2. CLEAN AND WASH DOWN BOTH INSIDE AND OUTSIDE OF ENTIRE MACHINE THOROUGHLY WITH HOT WATER AND CLEANING AGENT. AVOID USING HARSH CAUSTIC CLEANERS ON MACHINE.
3. WASH OFF ALL BONE DUST AND MEAT PARTICLES FROM INSIDE OF FRAMES, AROUND WHEELS AND GUIDES.
4. SPRAY BOTH INSIDE AND OUTSIDE OF MACHINE WITH A LIGHT COAT OF MINERAL OIL.

## WATER CONNECTION

A BULKHEAD FITTING, FIGURE 1, ITEM 10, IS PROVIDED AT THE BASE OF DRIVE SIDE FRAME, ITEM 11, FOR CONNECTION TO COLD WATER. ADJUST CONNECTOR AND NOZZLE, ITEMS 12 AND 13, TO CLEAN BONE DUST FROM DRIVE WHEEL AND MEAT PARTICLES TRAPPED BETWEEN TEETH OF SAW BLADE. FITTING AND HOSE, ITEMS 14 AND 15, AT BASE OF DRIVE SIDE FRAME, ARE PROVIDED FOR DRAINAGE OF WASTE WATER.

## TORQUE WRENCH CALIBRATION

TORQUE WRENCH, ITEM 5, IS CALIBRATED AND PRESET TO 55 INCH/LBS AT FACTORY. PERIODICALLY CHECK CALIBRATION BY USE OF ANOTHER TORQUE WRENCH WITH A DIAL TO MAKE ADJUSTMENT AND RESET TORQUE WRENCH TO 55 INCH/LBS. REMOVE TORQUE WRENCH COVER TO **CLEAN AND LUBRICATE PERIODICALLY.**

### TESTING AND SETTING OF TORQUE WRENCH:

#### TOOLS REQUIRED:

- HEX WRENCH -- 3/16"
- HEX BAR -- 1/2", ABOUT 3"-6" LONG
- HEX SOCKET -- 1/2" WITH DRIVE END TO MATCH COMMERCIAL WRENCH SELECTED
- TORQUE WRENCH, COMMERCIAL DIAL TYPE PREFERABLE
- SCREWDRIVER -- 3/8"-7/16" FLAT BLADE

#### STEP 1 -- TESTING KENTMASTER TORQUE WRENCH

- A. ATTACH COMMERCIAL TORQUE WRENCH TO KENTMASTER TORQUE WRENCH USING 1/2" HEX BAR AND 1/2" HEX SOCKET.
- B. HOLD ASSEMBLY FIRMLY AND ROTATE KENTMASTER TORQUE WRENCH CLOCKWISE SLOWLY UNTIL WRENCH "***SLIPS***".
- C. INDICATOR NEEDLE ON COMMERCIAL TORQUE WRENCH SHOULD READ 55 IN/LBS  $\pm$ 3 IN/LBS (5%). IF OVER OR UNDER VALUE, PROCEED TO STEP 2 -- RESETTING KENTMASTER TORQUE WRENCH.

#### STEP 2 -- RESETTING KENTMASTER TORQUE WRENCH

- A. USING 3/16" HEX WRENCH, REMOVE FOUR (4) SCREWS HOLDING THE WRENCH HANDLE IN PLACE. REMOVE HANDLE AND GASKET. SET ALL PARTS ASIDE FOR REUSE.
- B. HOLD WRENCH BODY SECURE BY EITHER CLAMPING SMALL DRIVE END IN VISE OR BY CLAMPING THE 1/2" HEX BAR IN VISE AND ATTACHING WRENCH TO BAR.

***NOTE: Do not clamp body of Torque Wrench in vise as severe damage to Torque Wrench could occur.***

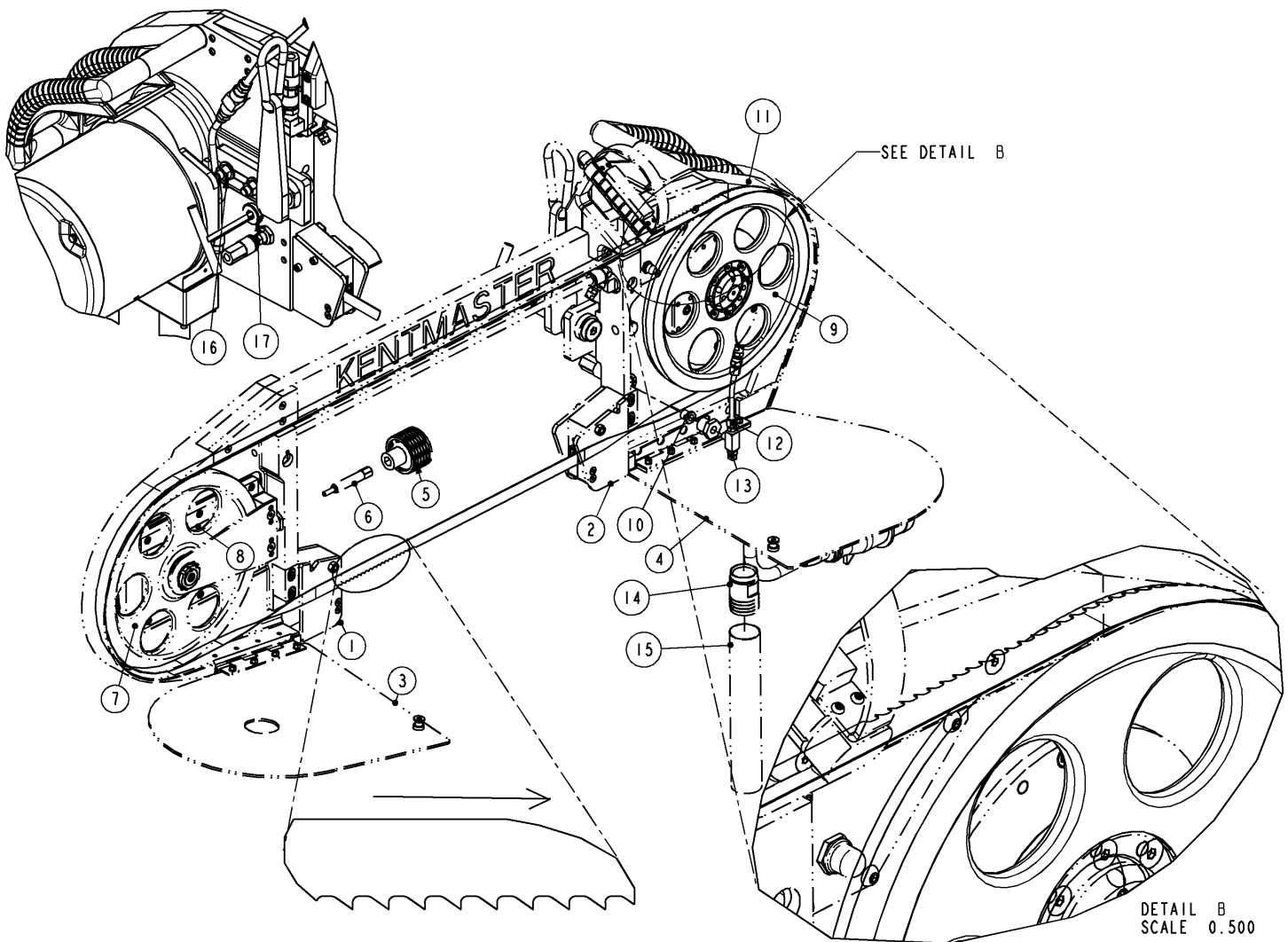
- C. USE FLAT BLADE SCREWDRIVER TO ADJUST THE FOUR (4) SET SCREWS UNDER WRENCH HANDLE. USE A STAGGERED PATTERN WHILE ADJUSTING, SUCH AS UPPER, LOWER, LEFT THEN RIGHT.
  - TO REDUCE TORQUE VALUE - BACK OFF SET SCREWS COUNTER-CLOCKWISE ABOUT 1/8 TURN EACH.
  - TO INCREASE TORQUE VALUE - TURN IN SET SCREWS CLOCKWISE ABOUT 1/8 TURN EACH.
- D. REASSEMBLE TORQUE WRENCH WITH HANDLE AND GASKET. RETEST PER STEP 1. CONTINUE TESTING AND SETTING UNTIL WRENCH OPERATES AT PROPER TORQUE VALUE.

## HANGER

THE SAW HANGER INCORPORATES TWO (2) ADJUSTMENT FEATURES. ADJUSTMENT "H" (HORIZONTAL) SHIFTS WEIGHT OF SAW FROM FRONT TO REAR ACCORDING TO OPERATOR PREFERENCE. WEIGHT OF SAW SHOULD BE ADJUSTED SO THAT NOSE OF SAW IS TIPPED DOWN SLIGHTLY FOR BETTER OPERATOR CONTROL. TO ADJUST, LOOSEN TWO (2) SCREWS, ITEMS 16, AND ADJUST ACCORDINGLY.

ADJUSTMENT "V" (VERTICAL) SHIFTS WEIGHT OF SAW FROM RIGHT TO LEFT, AFFECTING BLADE PATH AND STRAIGHTNESS OF CUT. NO ADJUSTMENT SHOULD BE REQUIRED AS MACHINES ARE ADJUSTED AT FACTORY FOR WEIGHT DISTRIBUTION FROM SIDE TO SIDE. IF THERE IS "SOFT-SIDING" OF CARCASS RESULTING FROM BLADE CUTTING TO LEFT OR RIGHT OF CENTERLINE, MAKE ADJUSTMENT AS FOLLOWS:

- **CUTTING EXCESSIVELY TO RIGHT** -- WITH A 3/8" HEX WRENCH, TURN SHAFT, ITEM 17, COUNTER-CLOCKWISE.
- **CUTTING EXCESSIVELY TO LEFT** -- WITH A 3/8" HEX WRENCH, TURN SHAFT, ITEM 17, CLOCKWISE.



**Figure 1 BM-V-**

**KENTMASTER MFG. CO., INC.** 1801 SOUTH MOUNTAIN AVE., MONROVIA, CALIFORNIA 91016 UNITED STATES OF AMERICA

☎ TELEPHONE: (626) 359-8888 FAX: (626) 303-5151

## **TROUBLE SHOOTING HINTS:**

- BE SURE DRIVE WHEEL IS TURNING COUNTER-CLOCKWISE (CCW) AND BLADE IS INSTALLED WITH TEETH POINTED TOWARD DRIVE FRAME.
- BE SURE BLADE TEETH ARE SITTING ABOVE UNDERCUT ON BOTH WHEELS SO AS NOT TO AFFECT SET OF TEETH.
- CHECK GAP BETWEEN CARBIDE INSERTS WHICH MUST NOT BE TOO TIGHT OR TOO LOOSE. BLADE SHOULD SLIDE THROUGH WITHOUT PLAY. MAKE ADJUSTMENT IF NECESSARY.
- REPLACE SAW BLADE IN CASE BLADE IS DEFECTIVE.
- ADJUST SAW HANGER (ADJUSTMENT "V") IF SAW CUTS OFF CENTER TO RIGHT OR LEFT.
- ADJUST HANGER ("H" ADJUSTMENT) IF SAW NOSE RISES TOO EASILY AND ADDITIONAL WEIGHT MUST BE SHIFTED FORWARD.
- BE SURE SAW IS NOT DROPPING DOWN TOO QUICKLY. ADJUST BALANCER.
- BLADE OVER OR UNDER TORQUED. CHECK TORQUE WRENCH CALIBRATION.

### **BAD SPLIT**

### **UNEVEN SPLIT**

### **CUTS TO LEFT OR RIGHT**

- 
- CHECK IF BLADE IS BREAKING AT WELD. BLADE MAY BE DEFECTIVE.
  - WHEELS SLIPPING IN BLADE (EVIDENT BY VERY SHINY BLADE SURFACE). CHECK FOR INCORRECT TORQUE SETTING. CHECK TORQUE WRENCH CALIBRATION.
  - OPERATOR PUSHING SAW THROUGH BEEF EXCESSIVELY.
  - BLADE OVER OR UNDER TORQUED. CHECK TORQUE WRENCH CALIBRATION.
  - CHECK FOR PROPER GAP (.025"-.028", .64-.71mm) BETWEEN CARBIDE INSERTS.

### **PREMATURE BLADE CRACKING OR BREAKING**

- 
- CHECK FOR BONE DUST BUILD-UP AT GUIDES. CLEAN OUT AND INCREASE WATER FLOW IF NECESSARY.
  - CHECK IF BLADE IS SLIPPING ON WHEELS. LOOK FOR CAUSE AND CORRECT.
  - CHECK FOR PROPER GAP (.025"-.028", .64-.71mm) BETWEEN CARBIDE INSERTS. GAP MAY BE TOO TIGHT, CAUSING INSERTS TO MACHINE SIDES OF BLADE.
  - CHECK FOR CHIPPED OR CRACKED CARBIDE INSERTS AT BLADE GUARD ASSEMBLIES. ROTATE OR REPLACE IF NECESSARY.
  - WITH BLADE REMOVED, CHECK TAKE-UP WHEEL TO BE SURE IT SPINS FREELY.

### **BLACK APPEARS ON BACKBONE**

- 
- CHECK WHEELS FOR PLAY, LOOSENESS OR LOOSE SCREWS OR NUTS. CHECK TAKE-UP WHEEL BRACKET, TIGHTEN AND CORRECT PLAY.
  - CHECK WHEEL BEARINGS AND REPLACE IF DEFECTIVE.

### **BLADE SLIPS OFF WHEELS**

- CHECK WHEELS FOR ROUNDNESS AND WEAR. BE SURE WHEEL FACES ARE NOT TAPERED OR HAVE FLAT SPOTS DUE TO WEAR. REPLACE IF DEFECTIVE.
- CHECK TAKE-UP WHEEL FOR PROPER TORQUE SETTING.
- LOOK FOR ANY BLADE OBSTRUCTIONS.
- CHANGE SAW BLADE. BLADE MAY BE DEFECTIVE.

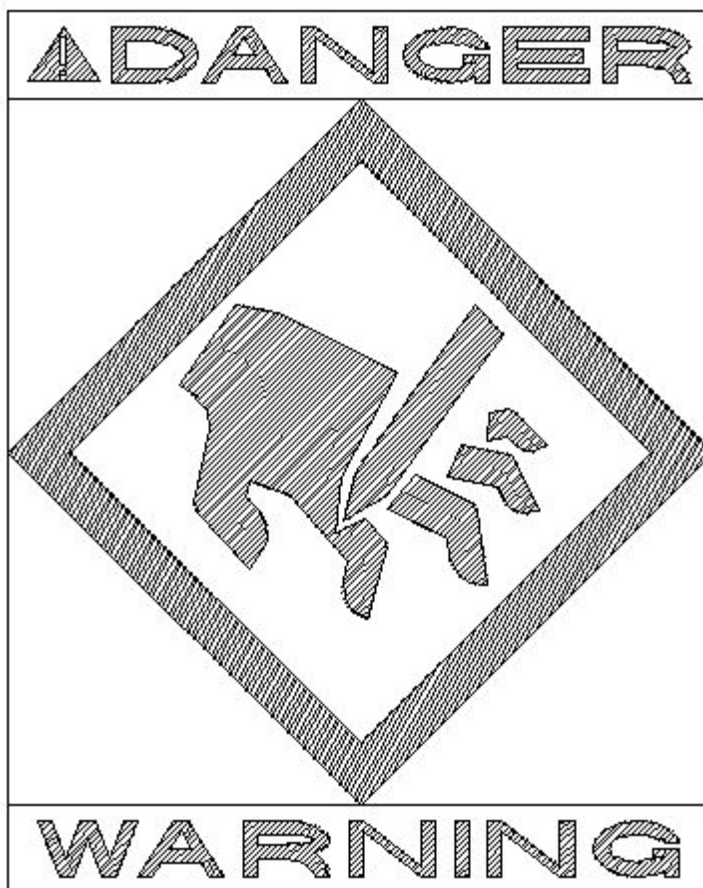
**MOTOR PULLS EXCESSIVE  
AMPERAGE (WITHOUT LOAD)  
OR  
BLADE IS TOO LOOSE WHILE  
TORQUE WRENCH IS  
PROPERLY CALIBRATED**

- REMOVE BLADE FROM MACHINE. BACK OFF SCREW, ITEM 6, WITH TORQUE WRENCH. GRAB TAKE-UP WHEEL WITH BOTH HANDS AND SLIDE BACK AND FORTH. IT SHOULD SLIDE FREELY. IF IT BINDS OR TAKES EXCESSIVE EFFORT, DISASSEMBLE COMPLETELY. CHECK TO SEE IF GIBS LOCATED ON EACH SIDE OF SLIDE ARE TOO CLOSE AND TIGHT AGAINST SLIDE. LOOSEN SCREWS THAT HOLD GIB IN PLACE. SPREAD GIBS SLIGHTLY OUT AND RETIGHTEN SCREWS. SLIDE SHOULD MOVE BACK AND FORTH FREELY, BUT WITHOUT UP AND DOWN PLAY. REASSEMBLE AND TEST MACHINE. LUBRICATE SURFACES BETWEEN SLIDE AND GIB.

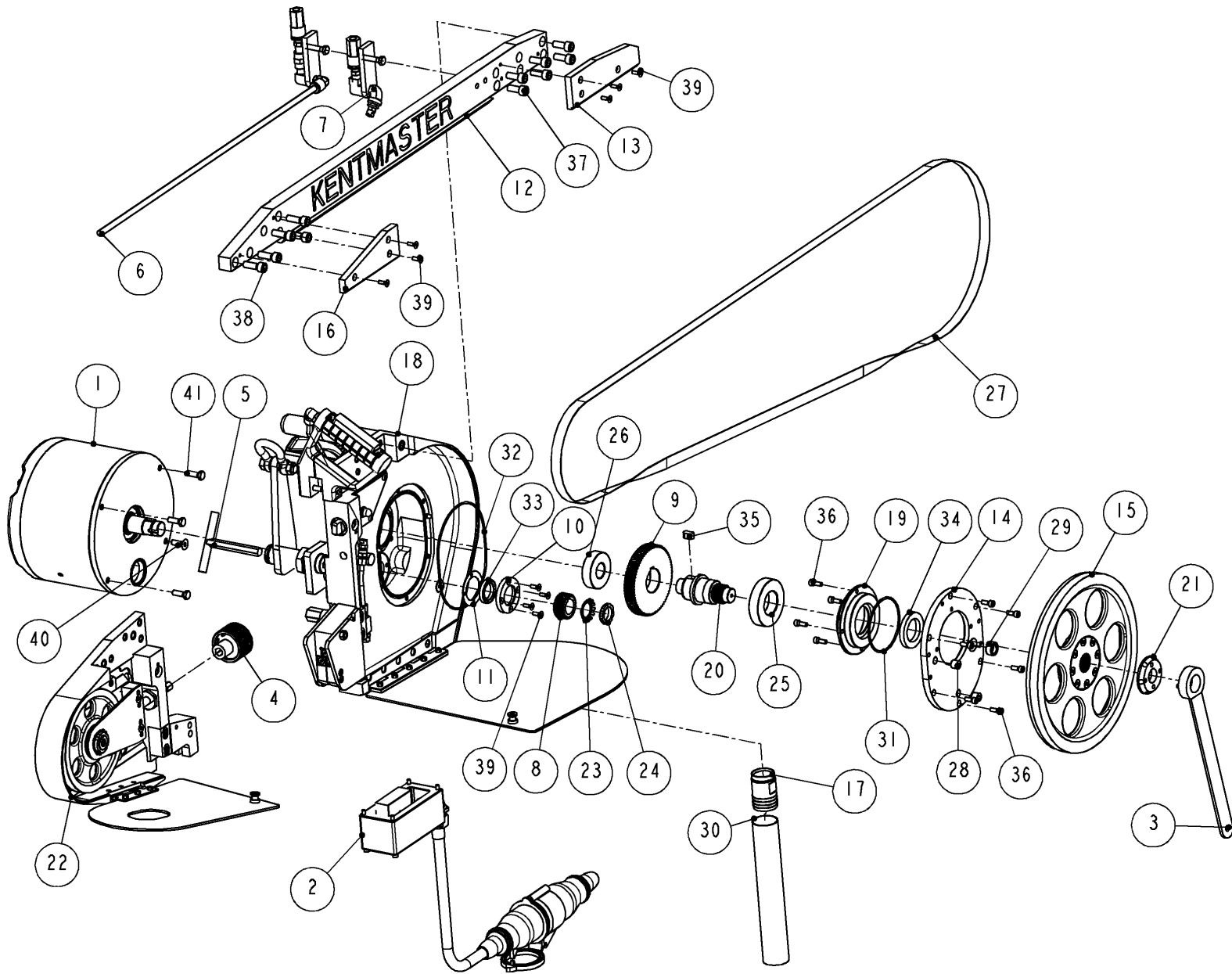
---

## **SERVICE**

1. KEEP GOOD RECORDS OF ALL SERVICE ACTIVITY AND INCLUDE TOOL IN PREVENTIVE MAINTENANCE PROGRAM.
2. USE ONLY GENUINE KENTMASTER REPLACEMENT PARTS TO ASSURE PROPER PERFORMANCE OF TOOL.
3. CONTACT THE KENTMASTER SUPPLIER NEAREST YOU FOR PARTS AND CUSTOMER SERVICE INFORMATION.



## **PARTS BOOKMODELS** **MAIN ASSEMBLIES**

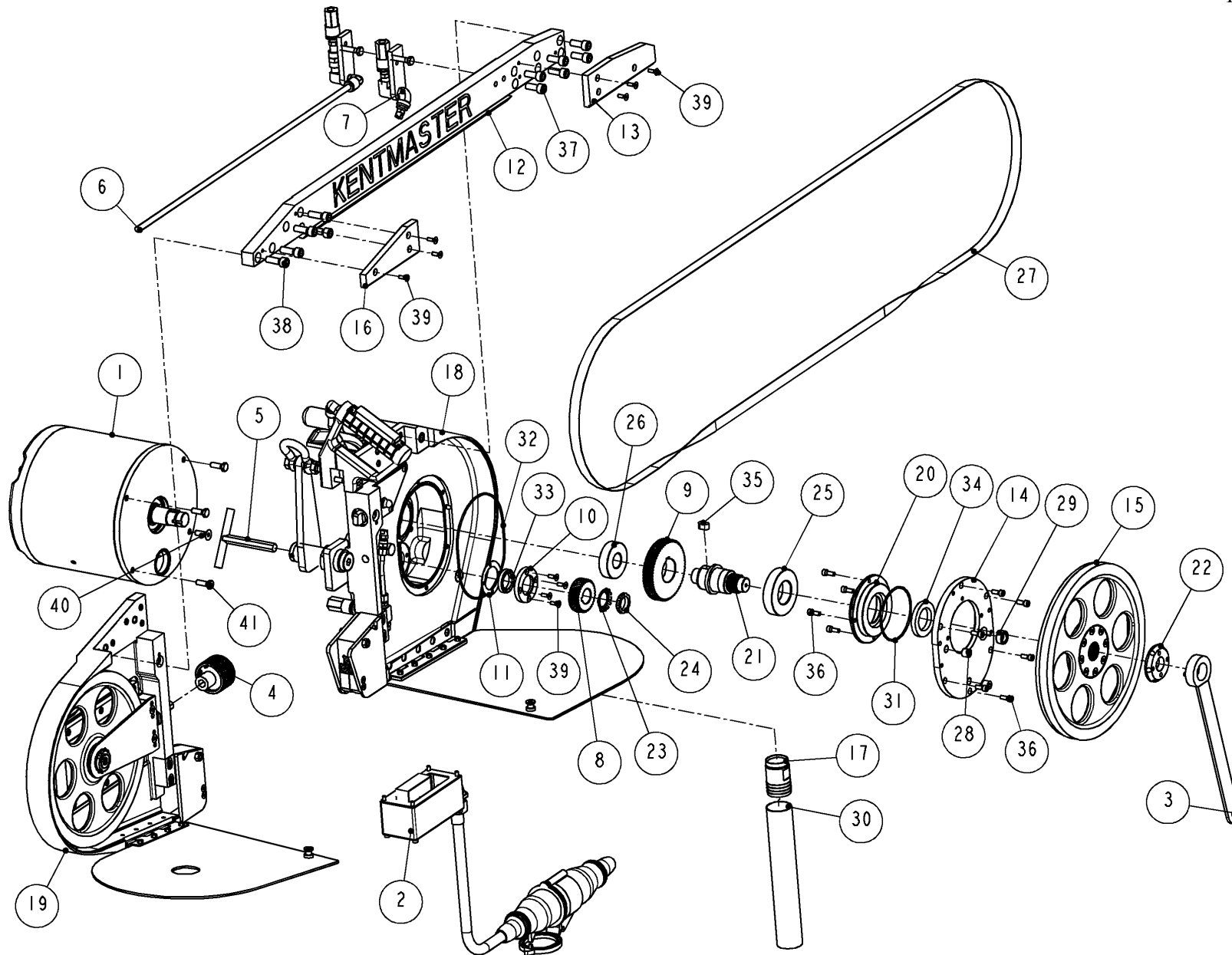


**Figure 2 MODELS BM-V-SDB AND BM-V-SD**



<b>1730000:BM-V-SDB / 1708100: BM-V-SD</b>			
ITEM	PART #	DESCRIPTION	QTY
1	OPTIONS	2HP MOTOR ASSEMBLY	1
	OPTIONS	3HP MOTOR ASSEMBLY	1
2	1720001	POWER SUPPLY, 42V, ANTI-TIE DOWN	1
	1720002	POWER SUPPLY, 42V, NO ANTI-TIE DOWN	1
	1720020	POWER SUPPLY, NON 42V, ANTI-TIE DOWN	1
	1720030	POWER SUPPLY, NON 42V, NO ANTI-TIE DOWN	1
	1720007	POWER SUPPLY, SINGLE PHASE, 115V / 230V	1
3	4501610	WRENCH / <b>TOOL</b>	1
4	1700900	TORQUE WRENCH / <b>TOOL</b>	1
5	1709790	WRENCH, ADJUSTMENT / <b>TOOL</b>	1
6	1709890	SPRAY TUBE ASSEMBLY / <b>OPTIONAL</b>	1
7	1710897	EXTERNAL SPRAY NOZZLE	1
8	1705590	GEAR, DRIVE / USE WITH MOTOR 60 Hz	1
	1705150	GEAR, DRIVE / USE WITH MOTOR 50Hz	1
9	1705850	GEAR, DRIVEN / USE WITH MOTOR 60 Hz	1
	1705770	GEAR, DRIVEN / USE WITH MOTOR 50Hz	1
10	1704130	CAP	1
11	1704220	GASKET	1
12	1708420	BEAM	1
13	1708430	COVER	1
14	1708460	COVER, GEAR	1
15	1708500	DRIVE WHEEL ASSEMBLY	1
16	1708610	COVER	1
17	1708840	FITTING	1
18	1709199	DRIVE SIDE ASSEMBLY / <b>BM-V-SDB</b>	1
	1709196	DRIVE SIDE ASSEMBLY / <b>BM-V-SD</b>	1
19	1709620	FLANGE	1
20	1709630	SHAFT	1
21	1710070	NUT	1
22	1730011	TAKE-UP SIDE ASSEMBLY / <b>BM-V-SDB</b>	1
	1709197	TAKE-UP SIDE ASSEMBLY / <b>BM-V-SD</b>	1
23	3000090	LOCKWASHER	1
24	3001090	LOCKNUT	1
25	3200080	BEARING	1
26	3316050	BEARING	1
27	4111000	BLADE / <b>BM-V-SDB</b>	1
	4111020	BLADE / <b>BM-V-SD</b>	1
28	7000020	PLUG	2
29	7240710	WINDOW	1
30	7300200	DISCHARGE HOSE	1
31	7681530	O-RING	1
32	7681650	O-RING	1
33	7798170	SEAL	1
34	7798220	SEAL	1
35	8607060	KEY	1
36	9211050	SCREW	10
37	9215080	SCREW	6
38	9215100	SCREW	5
39	9239050	SCREW	10
40	9243080	SCREW	1
41	9413070	SCREW	3

**Figure 3 BOM FOR MODELS BM-V-SDB AND BM-V-SD**



**Figure 4 MODEL BM-V-S**

<b>1708000: BM-V-S</b>			
ITEM	PART #	DESCRIPTION	QTY
1	OPTIONS	3HP MOTOR ASSEMBLY	1
	OPTIONS	5HP MOTOR ASSEMBLY	1
2	1720001	POWER SUPPLY, 42V, ANTI-TIE DOWN	1
	1720002	POWER SUPPLY, 42V, NO ANTI-TIE DOWN	1
	1720020	POWER SUPPLY, NON 42V, ANTI-TIE DOWN	1
	1720030	POWER SUPPLY, NON 42V, NO ANTI-TIE DOWN	1
3	4501610	WRENCH / <b>TOOL</b>	1
4	1700900	TORQUE WRENCH / <b>TOOL</b>	1
5	1709790	WRENCH, ADJUSTMENT / <b>TOOL</b>	1
6	1709890	SPRAY TUBE ASSEMBLY / <b>OPTIONAL</b>	1
7	1710897	EXTERNAL SPRAY NOZZLE	1
8	1704150	GEAR, DRIVE / FOR 60Hz FREQUENCY	1
	1704430	GEAR, DRIVE / FOR 50Hz FREQUENCY	1
9	1707340	GEAR, DRIVEN / FOR 60Hz FREQUENCY	1
	1707350	GEAR, DRIVEN / FOR 50Hz FREQUENCY	1
10	1704130	CAP	1
11	1704220	GASKET	1
12	1708420	BEAM	1
13	1708430	COVER	1
14	1708460	COVER, GEAR	1
15	1708500	DRIVE WHEEL ASSEMBLY	1
16	1708610	COVER	1
17	1708840	FITTING	1
18	1709192	DRIVE SIDE ASSEMBLY	1
19	1709194	TAKE-UP SIDE ASSEMBLY	1
20	1709620	FLANGE	1
21	1709630	SHAFT	1
22	1710070	NUT	1
23	3000090	LOCKWASHER	1
24	3001090	LOCKNUT	1
25	3200080	BEARING	1
26	3316050	BEARING	1
27	4111030	BLADE	1
28	7000020	PLUG	2
29	7240710	WINDOW	1
30	7300200	DISCHARGE HOSE	1
31	7681530	O-RING	1
32	7681650	O-RING	1
33	7798170	SEAL	1
34	7798220	SEAL	1
35	8607060	KEY	1
36	9211050	SCREW	10
37	9215080	SCREW	6
38	9215100	SCREW	5
39	9239050	SCREW	10
40	9243080	SCREW	1
41	9413070	SCREW	3

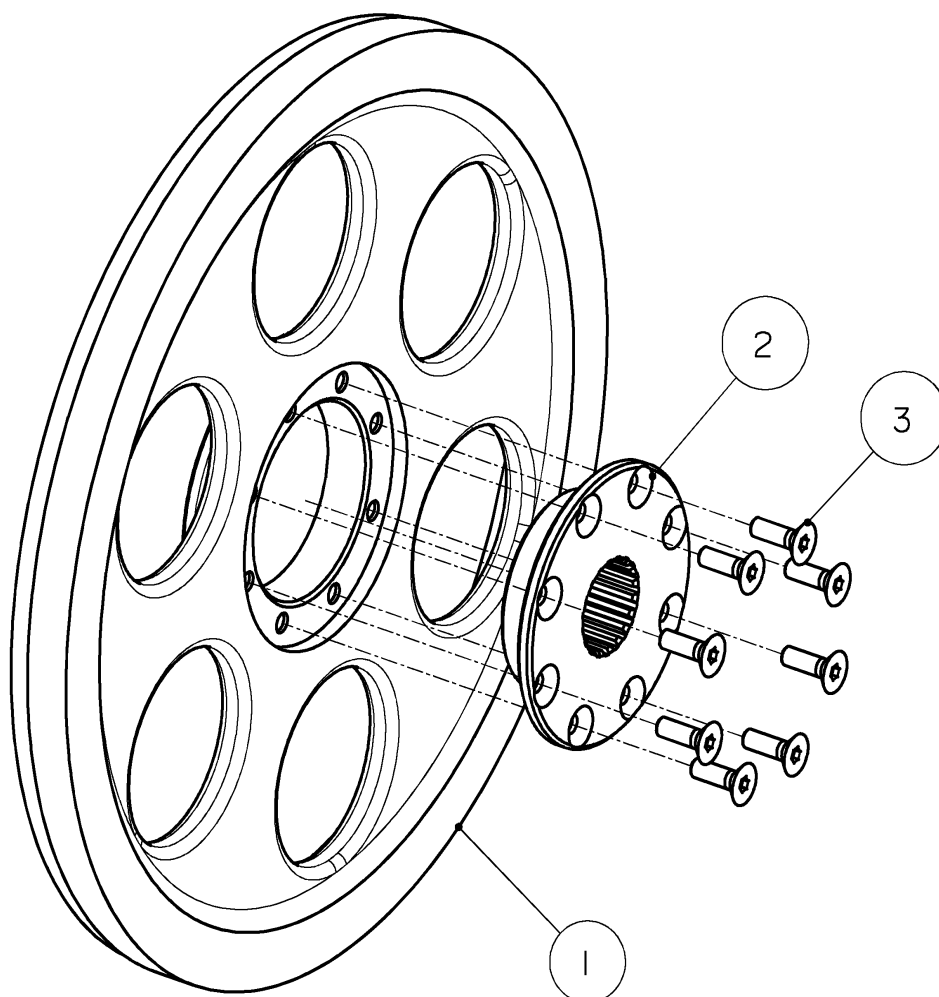
**Figure 5 BOM FOR MODEL BM-V-S**



<b>1708050: BM-V-SB</b>			
<b>ITEM</b>	<b>PART #</b>	<b>DESCRIPTION</b>	<b>QTY</b>
1	OPTIONS	3HP MOTOR ASSEMBLY	1
	OPTIONS	5HP MOTOR ASSEMBLY	1
2	1720001	POWER SUPPLY, 42V, ANTI-TIE DOWN	1
	1720002	POWER SUPPLY, 42V, NO ANTI-TIE DOWN	1
	1720020	POWER SUPPLY, NON 42V, ANTI-TIE DOWN	1
	1720030	POWER SUPPLY, NON 42V, NO ANTI-TIE DOWN	1
3	4501610	WRENCH / <b>TOOL</b>	1
4	1700900	TORQUE WRENCH / <b>TOOL</b>	1
5	1709790	WRENCH, ADJUSTMENT / <b>TOOL</b>	1
6	1709910	SPRAY TUBE ASSEMBLY / <b>OPTIONAL</b>	1
7	1710897	EXTERNAL SPRAY	1
8	1705150	GEAR, DRIVE / FOR 60Hz FREQUENCY	1
	1704150	GEAR, DRIVE / FOR 50Hz FREQUENCY	1
9	1705770	GEAR, DRIVEN / FOR 60Hz FREQUENCY	1
	1707340	GEAR, DRIVEN / FOR 50Hz FREQUENCY	1
10	1704130	CAP	1
11	1704220	GASKET	1
12	1708460	COVER, GEAR	1
13	1708610	COVER	1
14	1708790	DRIVE WHEEL ASSEMBLY	1
15	1708805	DRIVE SIDE ASSEMBLY	1
16	1708820	BEAM	1
17	1708840	FITTING	1
18	1709505	TAKE-UP SIDE ASSEMBLY	1
19	1709600	COVER	1
20	1709620	FLANGE	1
21	1709630	SHAFT	1
22	1710070	NUT	1
23	3000090	LOCKWASHER	1
24	3001090	LOCKNUT	1
25	3200080	BEARING	1
26	3316050	BEARING	1
27	4111100	BLADE	1
28	7000020	PLUG	2
29	7240710	WINDOW	1
30	7300200	DISCHARGE HOSE	1
31	7681530	O-RING	1
32	7681650	O-RING	1
33	7798170	SEAL	1
34	7798220	SEAL	1
35	8607060	KEY	1
36	9211050	SCREW	10
37	9215080	SCREW	6
38	9215100	SCREW	5
39	9239050	SCREW	10
40	9243080	SCREW	1
41	9413070	SCREW	3

**Figure 7 BOM FOR MODEL BM-V-SB**

**DRIVE WHEEL ASSEMBLY**

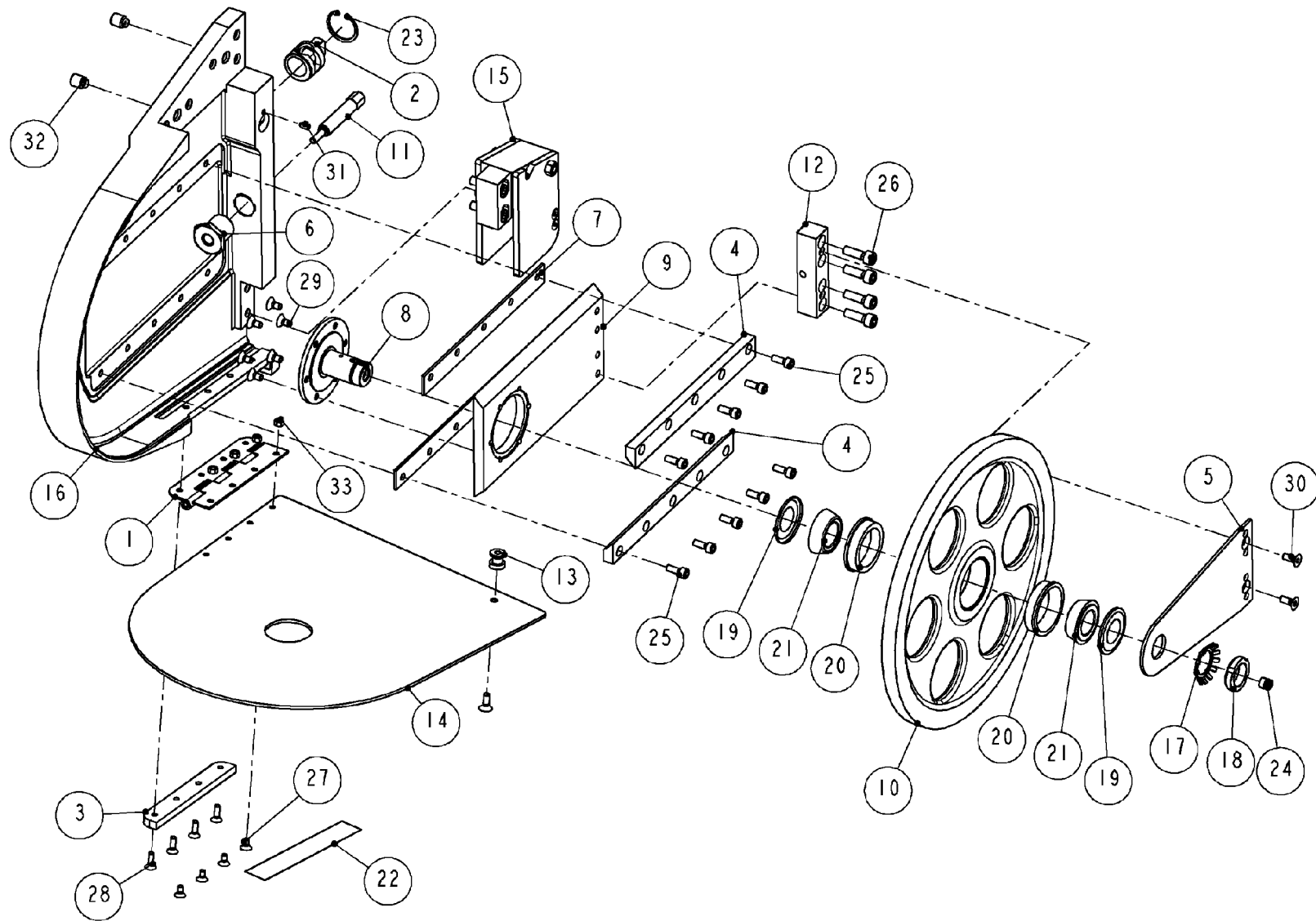


<b>1708500: DRIVE WHEEL ASSEMBLY ASSEMBLY</b>			
<b>FOR BM-V-SDB,SD,S</b>			
<b>ITEM</b>	<b>PART #</b>	<b>DESCRIPTION</b>	<b>QTY</b>
1	1708510	WHEEL, DRIVE	1
2	1708520	INSERT	1
3	9241060	SCREW	8

<b>1708790: DRIVE WHEEL ASSEMBLY ASSEMBLY</b>			
<b>FOR BM-V-SB</b>			
<b>ITEM</b>	<b>PART #</b>	<b>DESCRIPTION</b>	<b>QTY</b>
1	1708700	WHEEL, DRIVE	1
2	1708520	INSERT	1
3	9241060	SCREW	8

**Figure 8 DRIVE WHEEL ASSEMBLY**

**TAKE-UP SIDE ASSEMBLY**



**Figure 9 TAKE-UP SIDE ASSEMBLY**

**KENTMASTER MFG. CO., INC.** 1801 SOUTH MOUNTAIN AVE., MONROVIA, CALIFORNIA 91016 UNITED STATES OF AMERICA

☎ TELEPHONE: (626) 359-8888 FAX: (626) 303-5151

		<b>TAKE-UP SIDE ASSEMBLY</b>	1730011	1709197	1709194	1709505
ITEM	PART #	DESCRIPTION	QTY	QTY	QTY	QTY
			MODEL	MODEL	MODEL	MODEL
			BM-V-SDB	BM-V-SD	BM-V-S	BM-V-SB
1	1704560	HINGE ASSEMBLY	-	-	1	1
	1709590	HINGE ASSEMBLY	1	1	-	-
2	1704670	KNOB	1	1	1	1
3	1704710	PLATE	-	-	1	1
	1709570	PLATE	1	1	-	-
4	1704780	GIB	-	-	2	2
	1709550	GIB	2	2	-	-
5	1704790	HOLDER, SHAFT	-	-	1	1
	1706360	HOLDER, SHAFT	1	1	-	-
6	1704800	INSERT, ADJUSTABLE SCREW	1	1	1	1
7	1704810	SPACER	-	-	2	2
	1709560	SPACER	2	2	-	-
8	1708470	SHAFT	1	1	1	1
9	1708490	SLIDE	-	-	1	1
	1708930	SLIDE	1	1	-	-
10	1708530	WHEEL, TAKE-UP	-	-	1	1
	1708710	WHEEL, TAKE-UP	-	1	-	-
	1730220	WHEEL, TAKE-UP	1	-	-	-
11	1708560	SCREW, ADJUSTABLE	-	-	1	1
	1709530	SCREW, ADJUSTABLE	1	1	-	-
12	1708570	BLOCK, SLIDE	1	1	1	1
13	1708590	CATCH	1	1	1	1
14	1708600	COVER	-	-	1	1
	1708900	COVER	-	1	-	-
	1730230	COVER	1	-	-	-
15	1709090	BLADE GUIDE ASSEMBLY	-	-	1	1
	1709340	BLADE GUIDE ASSEMBLY	1	1	-	-
16	1709500	FRAME, TAKE-UP SIDE	-	-	-	1
	1708410	FRAME, TAKE-UP SIDE	-	-	1	-
	1708850	FRAME, TAKE-UP SIDE	-	1	-	-
	1730210	FRAME, TAKE-UP SIDE	1	-	-	-
17	3000080	LOCKWASHER	1	1	1	1
18	3001500	LOCKNUT	1	1	1	1
19	3005280	NILOS RING	2	2	2	2
20	3650590	BEARING CUP	2	2	2	2
21	3650960	TAPER BEARING CONE	2	2	2	2
22	4505020	LABEL, DANGER/WARNING	1	1	1	1
23	5001250	RETAINING RING	1	1	1	1
24	7018150	FITTING - LUBE	1	1	1	1
25	9211050	SCREW	6	6	10	10
26	9213080	SCREW	4	4	4	4
27	9239030	SCREW	3	3	4	4
28	9239050	SCREW	3	3	4	4
29	9241030	SCREW	6	6	6	6
30	9241050	SCREW	3	3	3	3
31	9333000	SET SCREW	1	1	1	1
32	9333070	SET SCREW	2	2	2	2
33	9500090	NUT	3	3	4	4

#### TAKE-UP WHEEL ADJUSTMENT

TAKE-UP WHEEL, ITEM 10, MUST TURN FREELY BUT WITHOUT EXCESSIVE PLAY OR LOOSENESS. ELIMINATE EXCESSIVE PLAY BY TIGHTENING NUT, ITEM 18, AT CENTAR OF TAKE-UP WHEEL.

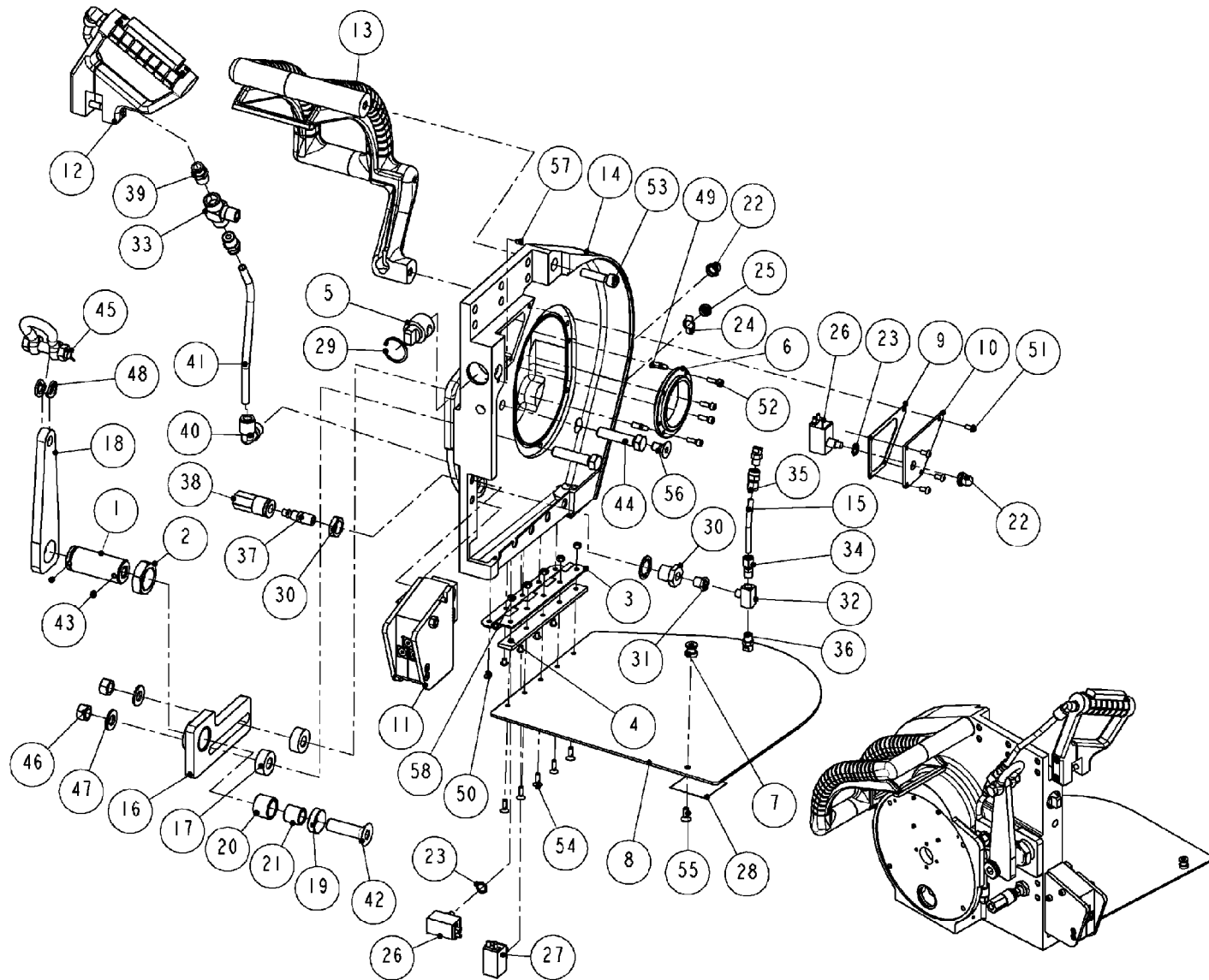
#### **Figure 10 TAKE-UP SIDE ASSEMBLY BOM**

**KENTMASTER MFG. CO., INC.** 1801 SOUTH MOUNTAIN AVE., MONROVIA, CALIFORNIA 91016 UNITED STATES OF AMERICA

☎ TELEPHONE: (626) 359-8888 FAX: (626) 303-5151



**DRIVE SIDE ASSEMBLY**



**Figure 11 DRIVE SIDE ASSEMBLY**

**KENTMASTER MFG. CO., INC.** 1801 SOUTH MOUNTAIN AVE., MONROVIA, CALIFORNIA 91016 UNITED STATES OF AMERICA

☎ TELEPHONE: (626) 359-8888 FAX: (626) 303-5151

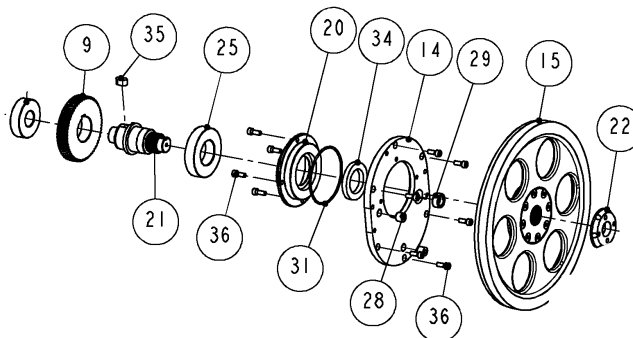
DRIVE SIDE ASSEMBLY			1709199	1709196	1709192	1708805
ITEM	PART #	DESCRIPTION	QTY MODEL BM-V-SDB	QTY MODEL BM-V-SD	QTY MODEL BM-V-S	QTY MODEL BM-V-SB
1	1704300	ADJUSTING SCREW	1	1	1	1
2	1704330	NUT, ADJUSTING SCREW	1	1	1	1
3	1704650	HINGE ASSEMBLY	1	1	1	-
	1705540	HINGE ASSEMBLY	-	-	-	1
4	1704660	SPACER, HINGE	1	1	1	-
	1705560	SPACER, HINGE	-	-	-	1
5	1704670	KNOB	1	1	1	1
6	1708550	FLANGE, REAR	1	1	1	1
7	1708590	CATCH	1	1	1	1
8	1708690	COVER, DRIVE SIDE	1	1	1	-
	1708780	COVER, DRIVE SIDE	-	-	-	1
9	1708990	GASKET	1	1	1	-
	1709380	GASKET	-	-	-	1
10	1709000	SWITCH COVER	1	1	1	-
	1709390	SWITCH COVER	-	-	-	1
11	1709101	BLADE GUIDE ASSEMBLY	1	-	-	-
	1709100	BLADE GUIDE ASSEMBLY	-	1	1	-
12	1709130	TOP HANDLE WITH SWITCH	1	1	1	1
13	1709193	REAR HANDLE ASSEMBLY	1	1	1	1
14	1709370	FRAME, DRIVE SIDE	1	1	-	-
	1708400	FRAME, DRIVE SIDE	-	-	1	-
	1708800	FRAME, DRIVE SIDE	-	-	-	1
15	1709661	TUBE	1	1	1	-
16	1709771	BAR HANGER	1	-	-	-
	1709770	BAR HANGER	-	1	1	1
17	1709772	SPACER	2	-	-	-
18	1709780	HANGER	1	1	1	1
19	1709860	WASHER	1	1	1	1
20	ASSEMBLY	1710030 BEARING	1	1	1	1
21	1710032	3706400 BEARING	1	1	1	1
22	2000020	BOOT, PUSH BUTTON	2	2	2	2
23	2000080	LOCKNUT	2	2	2	2
24	2000130	ON-OFF PLATE	1	1	1	1
25	2000140	BOOT, TOGGLE SWITCH	1	1	1	1
26	2000700	SWITCH, (PUSH BUTTON)	2	2	2	2
27	2000150	SWITCH, ON-OFF (TOGGLE)	1	1	1	1
28	4505030	LABEL, ELECTRIC ARROW	1	1	1	1
29	5001250	RETAINING RING	1	1	1	1
30	7001270	BULKHEAD COUPLING	1	1	1	1
31	7003650	PIPE BUSHING	1	1	1	1
32	7004400	TEE	1	1	1	1
33	7007730	MALE BRANCH TEE	1	1	1	1
34	7011230	CONNECTOR	1	1	1	-
35	7011530	CONNECTOR	1	1	1	-
36	7011650	SPRAY NOZLE	2	2	2	2
37	7034070	MALE PLUG	1	1	1	1
38	7034090	SOCKET	1	1	1	1
39	7036150	FITTING	2	2	2	2
40	7036450	ELBOW	1	1	1	1
41	7300754	TUBE	1	1	1	1

42	8250180	SCREW	1	1	1	1
43	8348080	SET SCREW	2	2	2	2
44	8418180	SCREW	2	-	-	-
	8418160	SCREW	-	2	2	2
45	8462080	ANCHOR SHACKLE	1	1	1	1
46	8500200	NUT	2	2	2	2
47	8505180	WASHER	2	2	2	2
48	8506180	WASHER	2	2	2	2
49	8622500	DOWEL PIN	2	2	2	2
50	9050020	SCREW	5	5	5	5
51	9050040	SCREW	4	4	4	4
52	9209050	SCREW	4	4	4	4
53	9215120	SCREW	1	1	1	-
	9245060	SCREW	-	-	-	1
54	9239050	SCREW	5	5	5	5
55	9241050	SCREW	1	1	1	1
56	9245060	SCREW	1	1	1	1
57	9333000	SET SCREW	1	1	1	1
58	9500090	NUT	5	5	5	5
ITEM	PART #	DESCRIPTION	QTY MODEL BM-V-SDB	QTY MODEL BM-V-SD	QTY MODEL BM-V-S	QTY MODEL BM-V-SB
<b>DRIVE SIDE ASSEMBLY</b>			1709199	1709196	1709192	1708805

**Figure 12 DRIVE SIDE ASSEMBLY BOM**

**TRANSMISSION**

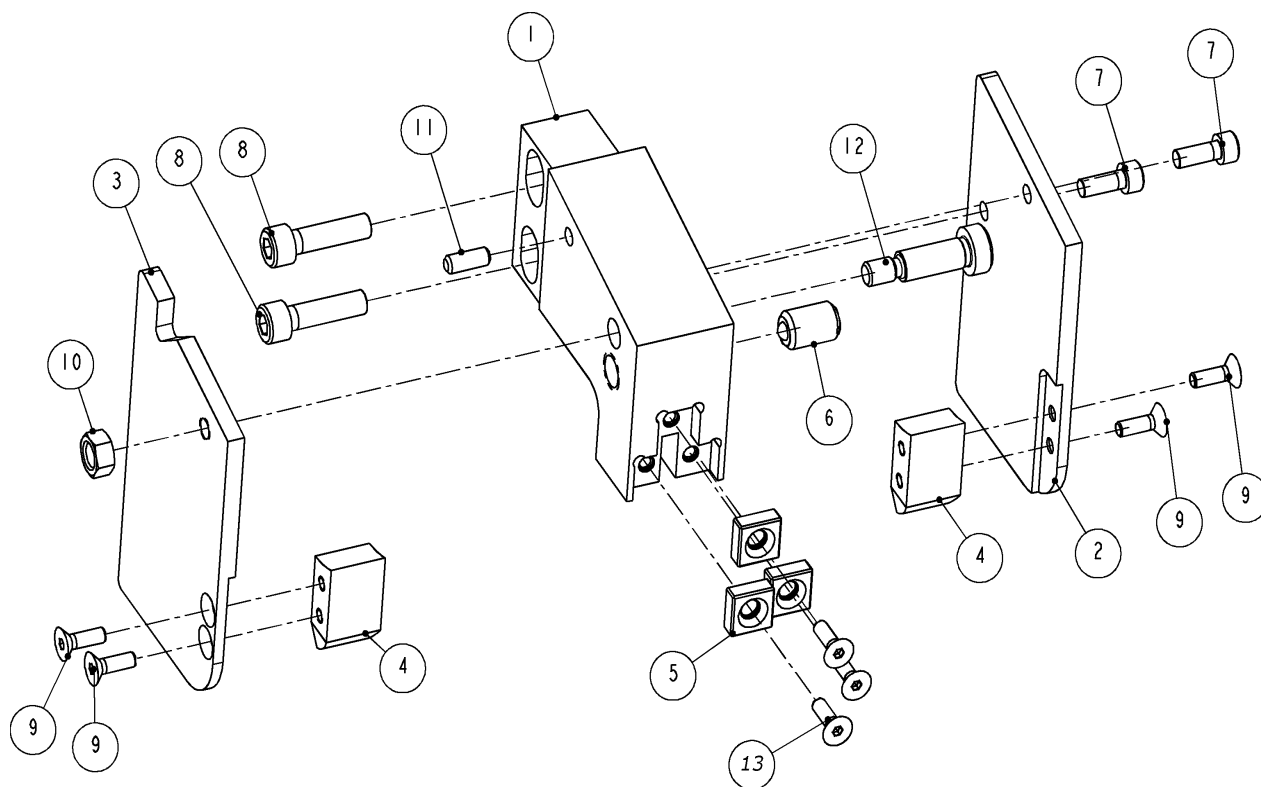
**REFERENCE:** MODEL BM-V-S  
FIGURE 3



**Figure 13 TRANSMISSION OVERVIEW**

TRANSMISSION AND SPEED REDUCTION GEARS ARE LOCATED BEHIND DRIVE WHEEL AND CAN BE SERVICED BY OPENING DRIVE WHEEL COVER. A ROUND GLASS SIGHT GAGE IS LOCATED BEHIND DRIVE WHEEL AND CAN BE VIEWED WITHOUT WHEEL REMOVAL. A PLUG IS LOCATED BELOW THE SIGHT GAGE FOR DRAINING AND ANOTHER ABOVE FOR FILLING WITH OIL. PERIODICALLY CHECK OIL LEVEL AND ADD OIL IF LEVEL BELOW SIGHT GAGE WITH SAW IN HORIZONTAL POSITION. IF OIL LOOKS CONTAMINATED WITH WATER, GRITTY OR BROKEN DOWN, DRAIN AND REFILL TO ABOVE SIGHT GAGE WITH HIGH QUALITY GEAR LUBRICANT. WE RECOMMEND MOBILUBE HD 80W-90 SAE 80W-90 GEAR LUBRICANT, MULTI-PURPOSE. TRANSMISSION SHOULD BE FLUSHED OUT AND REFILLED AFTER EVERY 200 HOURS OF OPERATION, AND WHEN OPENED UP FOR MAINTENANCE. THE GEAR LUBRICANT USED SHOULD ALSO BE USED FOR FLUSHING OUT TRANSMISSION.

**BLADE GUIDE ASSEMBLY, TAKE-UP SIDE**



1709090: BLADE GUIDE ASSEMBLY, FRONT			
ITEM	PART #	DESCRIPTION	QTY
1	1708630	GUIDE HOLDER	1
2	1708640	REAR GUARD	1
3	1708650	FRONT GUARD	1
4	1709110	GUIDE	2
5	8865050	CARBID INSERT	3
6	8895100	BALL PLUNGER	1
7	9211050	SCREW	2
8	9213100	SCREW	2
9	8239050	SCREW	4
10	9501430	NUT	1
11	9620450	PIN	1
12	9870340	SCREW	1
13	9239050	SCREW	3

**Figure 14 BLADE GUIDE ASSEMBLY, FRONT (BM-V-S & SB)**

**BLADE GUARD ADJUSTMENTS**

BLADE GUARD CONSISTS OF TWO (2) CARBIDE INSERTS, ITEM 5 FIGURE 14, THROUGH WHICH THE BLADE PASSES, AND A BACK-UP INSERT LOCATED JUST ABOVE THE BLADE. THE INSERTS SHOULD BE CLEANED DAILY AND INSPECTED PERIODICALLY FOR WEAR AND PROPER GAP WIDTH. THE INSERTS MAY BE ROTATED UNTIL ALL FOUR (4) SIDES ARE WORN, AND THEN TURNED OVER FOR AN ADDITIONAL FOUR (4) SIDES. THE BACK-UP INSERT SHOULD BE ROTATED WHEN A GROOVE IS WORN INTO IT OR WEAR IS APPARENT.

**GAP ADJUSTMENT:**

1. REMOVE FOUR (4) SCREWS, ITEM 9, FIGURE 14
2. CLEAN, LUBRICATE AND ROTATE OR REPLACE INSERTS.

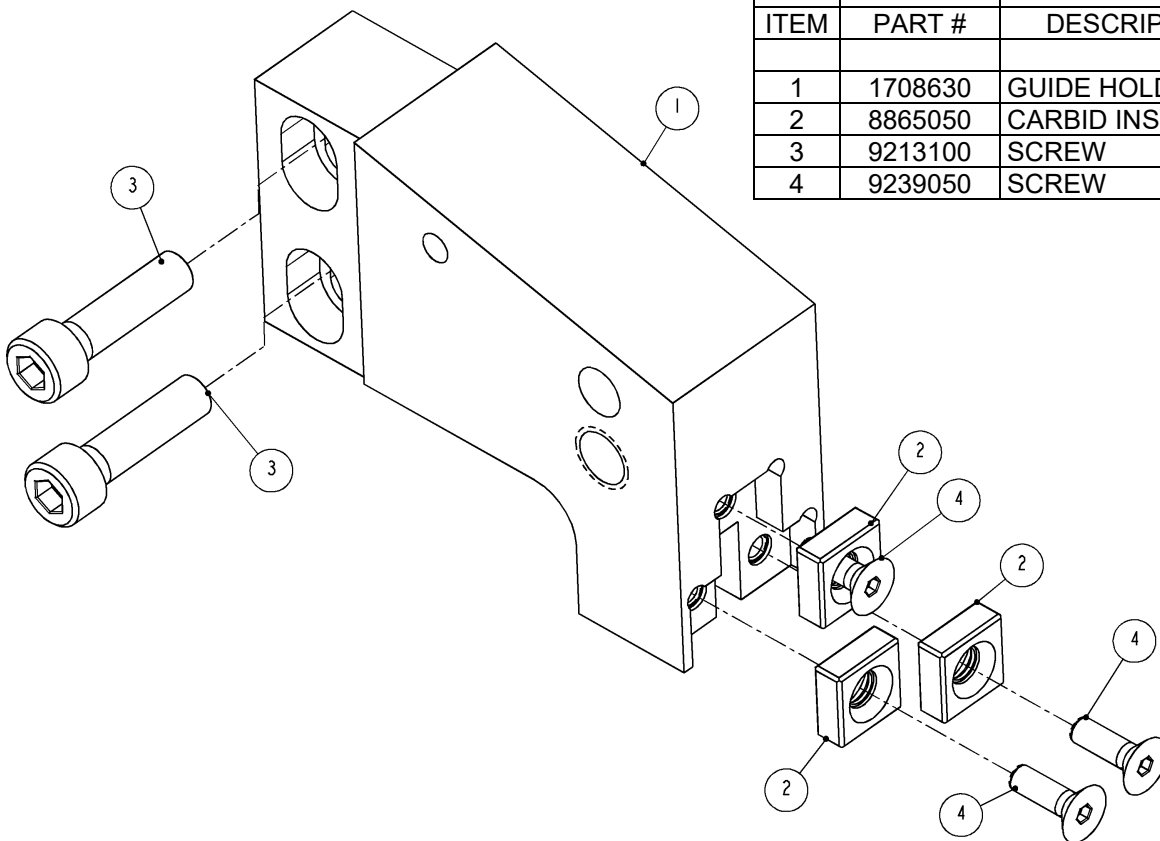
THERE ARE TWO (2) FIBER GUIDES, ITEM 4, LOCATED UNDER INSERTS. THEY HELP KEEP BLADE FROM BEING PULLED OUT OF GAP. REPLACE GUIDES IF EXCESSIVELY WORN.

WITH SAW IN FREE RUNNING CONDITION, CHECK BLADE'S VERTICAL LOCATION BETWEEN INSERTS. PROPER LOCATION IS TOP OF BLADE JUST TOUCHING BACK-UP INSERT.

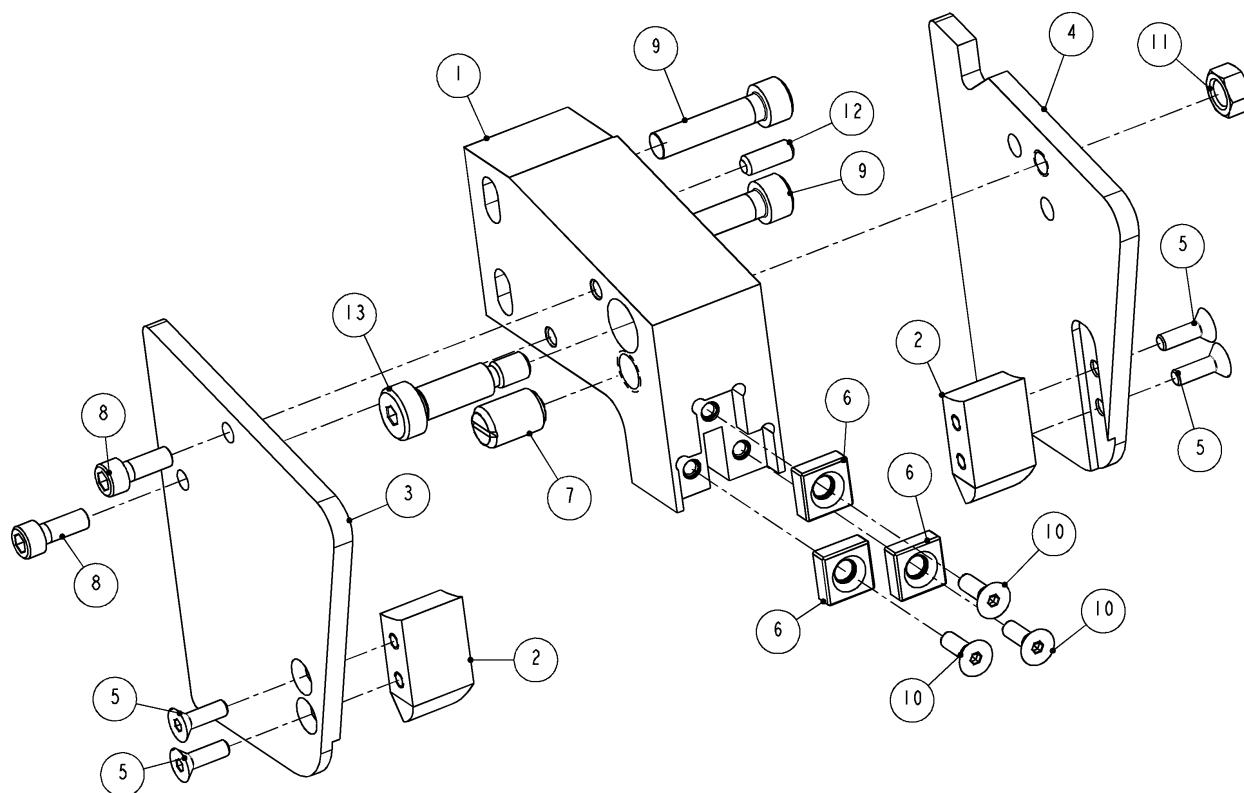
**VERTICAL ADJUSTMENT:**

1. LOOSEN TWO (2) SCREWS, ITEM 8.
2. SLIDE BLADE GUARD UP OR DOWN AS NEEDED.
3. RETIGHTEN SCREWS.

1709340:BLADE GUIDE ASSEMBLY, FRONT			
ITEM	PART #	DESCRIPTION	QTY
1	1708630	GUIDE HOLDER	1
2	8865050	CARBID INSERT	3
3	9213100	SCREW	2
4	9239050	SCREW	3



**Figure 15 BLADE GUIDE ASSEMBLY, FRONT (BM-V-SDB & SD)**

**BLADE GUIDE ASSEMBLY, DRIVE SIDE**

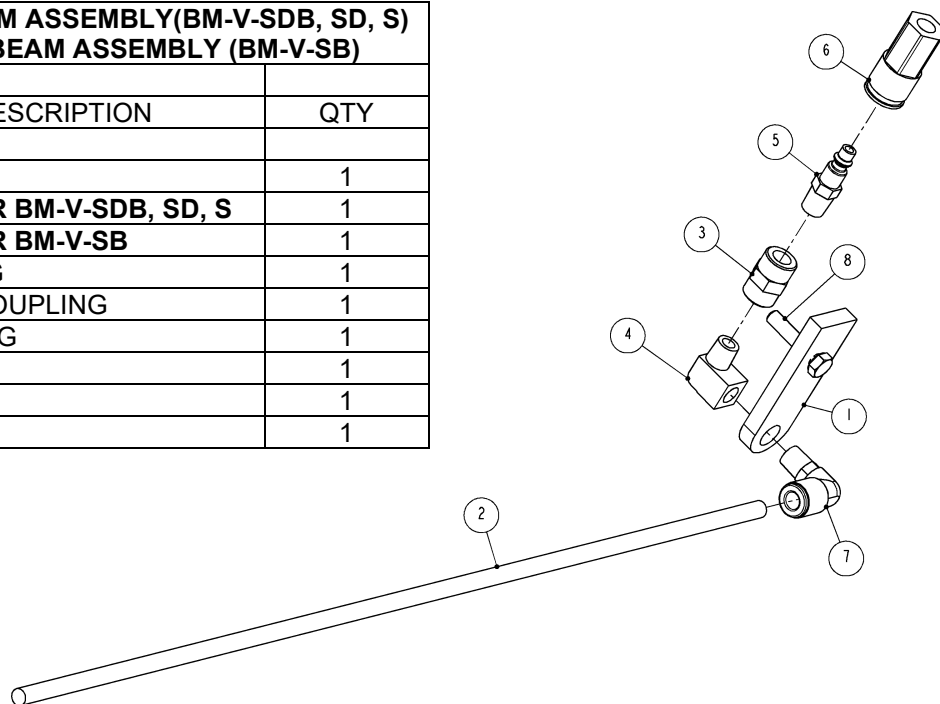
<b>1709100 (BM-V-SB, S, SD), 1709101 (BM-V-SDB): BLADE GUIDE ASSEMBLY, REAR</b>			
ITEM	PART #	DESCRIPTION	QTY
1	1708660	GUIDE HOLDER / <b>FOR 1709100 (BM-V-SB, S, SD)</b>	1
	1708661	GUIDE HOLDER / <b>FOR 1709101 (BM-V-SDB)</b>	1
2	1709110	GUIDE	2
3	1709750	REAR GUARD	1
4	1709760	FRONT GUARD	1
5	8239050	SCREW	4
6	8865050	CARBID INSERT	3
7	8895100	BALL PLUNGER	1
8	9211050	SCREW	2
9	9213110	SCREW	2
10	9239050	SCREW	3
11	9501430	NUT	1
12	9620450	PIN	1
13	9870340	SCREW	1

REFER TO "BLADE GUIDE ASSEMBLY, TAKE-UP SIDE" (FIGURE 13) FOR ADJUSTMENT INSTRUCTIONS.

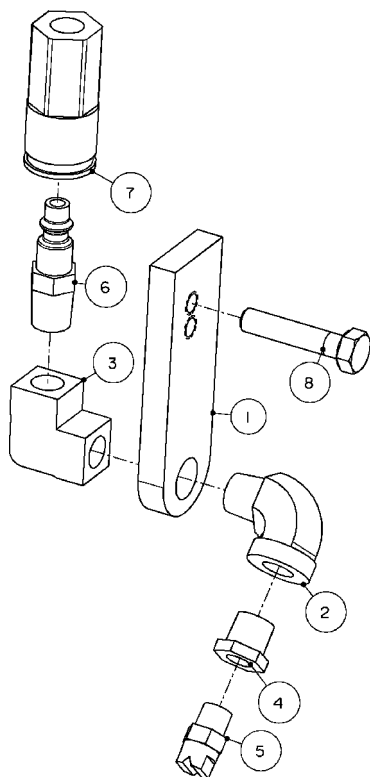
**Figure 16 BLADE GUIDE ASSEMBLY, DRIVE SIDE (BM-V-S, SB, SD, SDB)**

**ADDITIONAL SPRAY OPTIONS**

<b>1709890: SPRAY TUBE UNDER BEAM ASSEMBLY(BM-V-SDB, SD, S)</b>			
<b>1709910: SPRAY TUBE UNDER BEAM ASSEMBLY (BM-V-SB)</b>			
ITEM	PART #	DESCRIPTION	QTY
1	1709870	BRACKET	1
2	1709880	TUBE, <b>FOR BM-V-SDB, SD, S</b>	1
	1709900	TUBE, <b>FOR BM-V-SB</b>	1
3	7001110	COUPLING	1
4	7003110	ELBOW COUPLING	1
5	7034070	MALE PLUG	1
6	7034090	SOCKET	1
7	7036560	ELBOW	1
8	8413120	SCREW	1

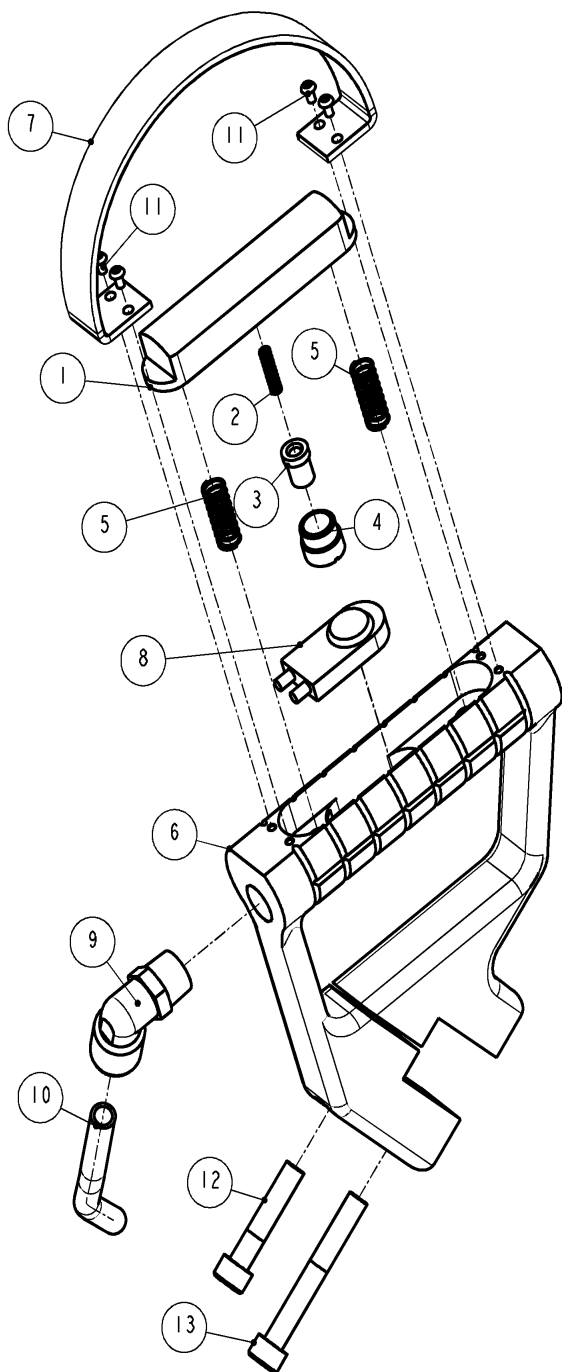


**Figure 17 SPRAY TUBE UNDER BEAM ASSEMBLY**



<b>1710897: EXTERNAL SPRAY NOZZLE</b>			
ITEM	PART #	DESCRIPTION	QTY
1	1709870	BRACKET	1
2	7000410	ELBOW	1
3	7004210	ELBOW	1
4	7003650	PIPE BUSHING	1
5	7011650	SPRAY NOZZLE	1
6	7034070	MALE PLUG	1
7	7034090	SOCKET	1
8	8413120	SCREW	1

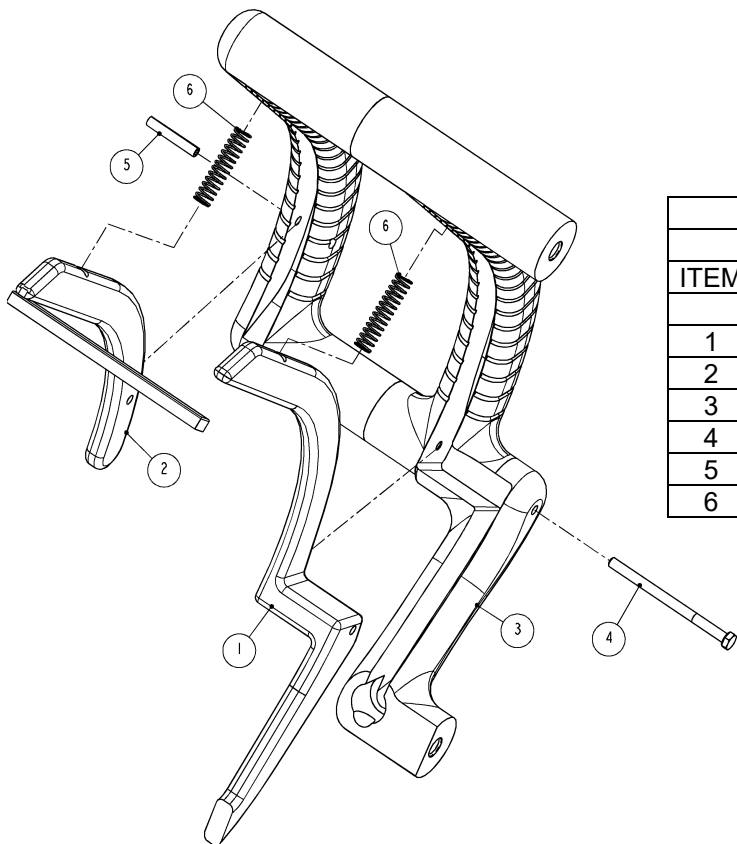
**Figure 18 1710897: EXTERNAL SPRAY NOZZLE**

**HANDLES**

<b>1709130: TOP HANDLE ASSEMBLY</b>			
<b>ITEM</b>	<b>PART #</b>	<b>DESCRIPTION</b>	<b>QTY</b>
1	1302430	TRIGGER	1
2	1302440	SPRING	1
3	1302450	PLUNGER	1
4	1302460	HOLDER, PLUNGER	1
5	1701550	SPRING	2
6	1708950	HANDLE	1
7	1710570	GUARD	1
8	2000690	SWITCH	1
9	7036450	ELBOW	1
10	7300753	TUBE	1
11	9045030	SCREW	4
12	9213120	SCREW	1
13	9213190	SCREW	1

**Figure 19 TOP HANDLE ASSEMBLY**

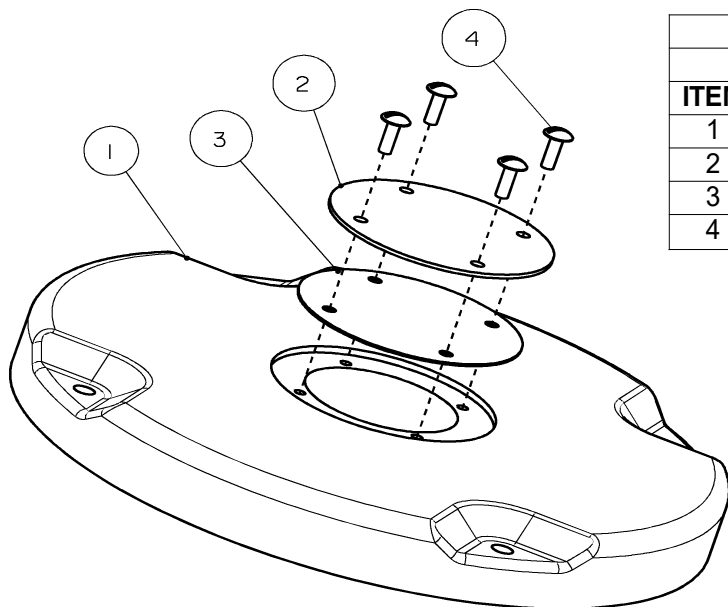




1709193: REAR HANDLE ASSEMBLY			
ITEM	PART #	DESCRIPTION	QTY
1	1708540	HANDLE TRIGGER	1
2	1709640	REAR HANDLE, TRIGGER	1
3	1710010	REAR HANDLA FRAME	1
4	8409240	SCREW	1
5	8613180	ROLL PIN	1
6	8890010	SPRING	2

**Figure 20 REAR HANDLE ASSEMBLY**

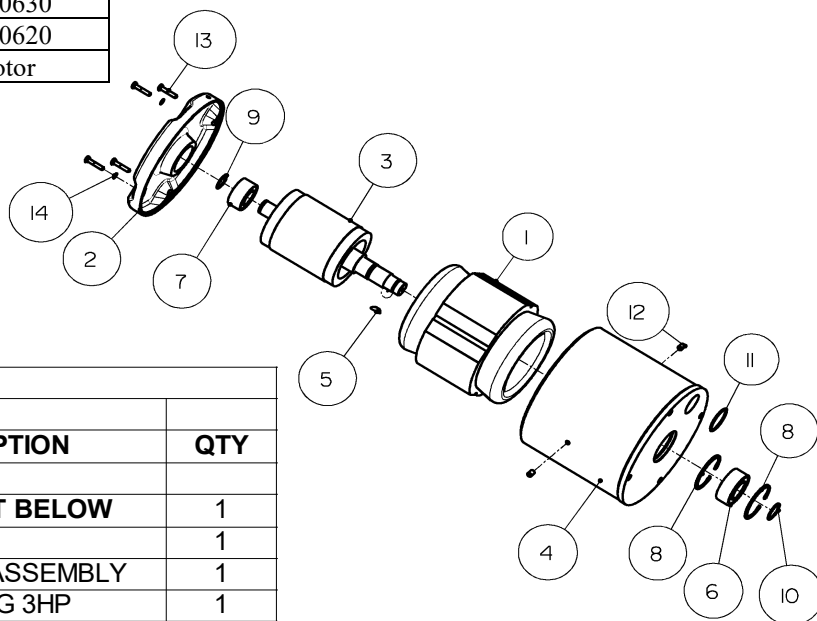
**MOTOR ASSEMBLY**



1501840: COVER			
ITEM	PART #	DESCRIPTION	QTY
1	1501810	COVER, MOTOR HOUSING	1
2	1501820	COVER	1
3	1501830	GASKET COVER	1
4	8108040	SCREW	4

**Figure 21 MOTOR COVER ASSEMBLY**

1703321	1703300	2340670
1703320	1703300	2340630
1703310	1703300	2340620
Rotor Shaft Ass'y	Motor Shaft	Rotor

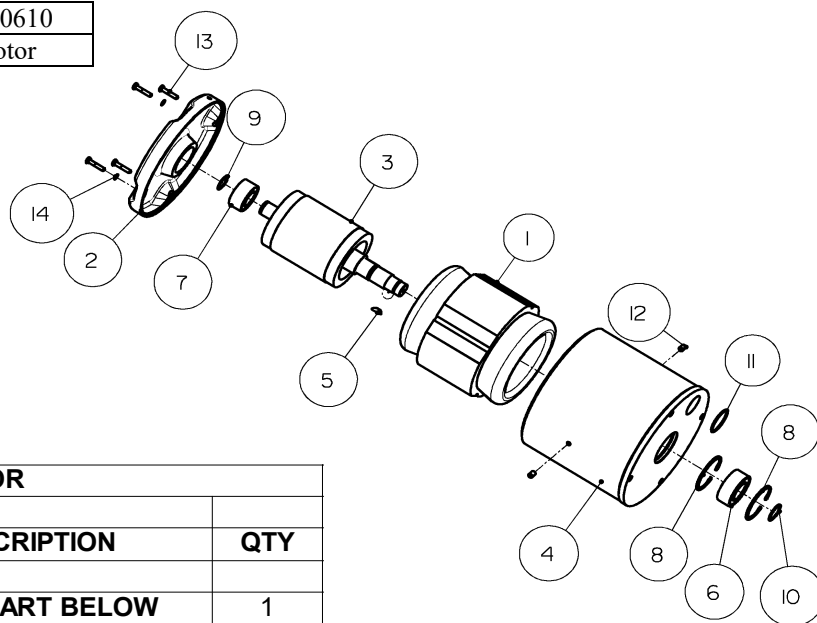


BM-V-2HP MOTOR			
ITEM	PART #	DESCRIPTION	QTY
1	<b>OPTIONS</b>	STATOR, CHART BELOW	1
2	1501840	COVER	1
3	<b>OPTIONS</b>	ROTOR-SHAFT ASSEMBLY	1
4	1703330	MOTOR HOUSING 3HP	1
5	1705620	KEY	1
6	3522060	BEARING	1
7	3524050	BEARING	1
8	5002440	RETAINING RING	2
9	5100980	RETAINING RING	1
10	5101180	RETAINING RING	1
11	7681300	O-RING	1
12	9313040	SET SCREW	2
13	9411080	SCREW	4
14	9507100	WASHER	4

MOTOR ASS'Y 230V, 2HP, 1PH, 50HZ, 12.2AMPS	1703470-230-150	2340270	1703321
MOTOR ASS'Y 115V, 2HP, 1PH, 50HZ, 24.4AMPS	1703470-115-150	2340270	1703321
MOTOR ASS'Y 230V, 2HP, 1PH, 60HZ, 11.7AMPS	1703460-230-160	2340260	1703320
MOTOR ASS'Y 115V, 2HP, 1PH, 60HZ, 23.4AMPS	1703460-115-160	2340260	1703320
MOTOR ASS'Y 42V, 2HP, 3PH, 50HZ, 36.0 AMPS	1703400	2340200	1703310
MOTOR ASS'Y 380V, 2HP, 3PH, 50HZ, 3.7 AMPS	1703420-380-350	2340220	1703310
MOTOR ASS'Y 220V, 2HP, 3PH, 50HZ, 6.4 AMPS	1703420-220-350	2340220	1703310
MOTOR ASS'Y 416V, 2HP, 3PH, 50HZ, 3.3 AMPS	1703430-416-350	2340230	1703310
MOTOR ASS'Y 208V, 2HP, 3PH, 50HZ, 6.6 AMPS	1703430-208-350	2340230	1703310
MOTOR ASS'Y 230V, 2HP, 3PH, 50HZ, 6.6 AMPS	1703410-230-350	2340210	1703310
MOTOR ASS'Y 115V, 2HP, 3PH, 50HZ, 13.2 AMPS	1703410-115-350	2340210	1703310
MOTOR ASS'Y 550V, 2HP, 3PH, 60HZ, 2.5AMPS	1703450	2340250	1703310
MOTOR ASS'Y 380V, 2HP, 3PH, 60HZ, 3.9 AMPS	1703440-380-360	2340240	1703310
MOTOR ASS'Y 220V, 2HP, 3PH, 60HZ, 6.8 AMPS	1703440-220-360	2340240	1703310
MOTOR ASS'Y 460V, 2HP, 3PH, 60HZ, 3.3 AMPS	1703430-460-360	2340230	1703310
MOTOR ASS'Y 230V, 2HP, 3PH, 60HZ, 6.6 AMPS	1703430-230-360	2340230	1703310
<b>MOTOR OPTION DESCRIPTION</b>	<b>MOTOR ASS'Y</b>	<b>STATOR</b>	<b>ROTOR</b>
<b>BM-V: 2HP MOTOR ASSEMBLY OPTIONS with STATOR</b>			

**Figure 22 2HP MOTOR OPTIONS**

1703350	1703340	2340610
Rotor Shaft Ass'y	Motor Shaft	Rotor

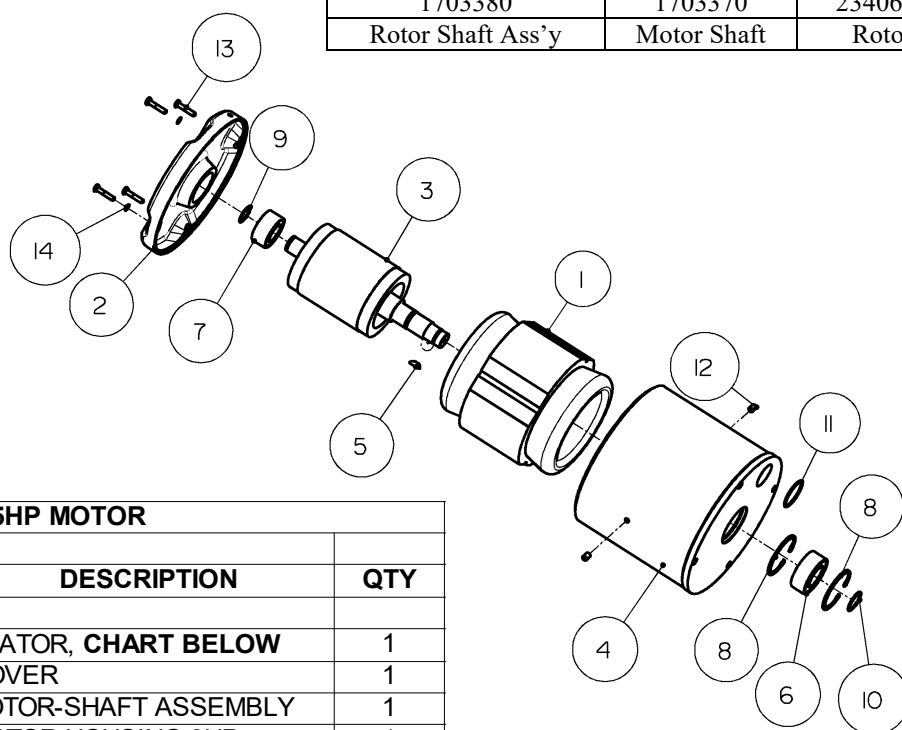


BM-V-3HP MOTOR			
ITEM	PART #	DESCRIPTION	QTY
1	<b>OPTIONS</b>	STATOR, <b>CHART BELOW</b>	1
2	1501840	COVER	1
3	1703350	ROTOR-SHAFT ASSEMBLY	1
4	1703360	MOTOR HOUSING 3HP	1
5	8600680	KEY	1
6	3522060	BEARING	1
7	3524050	BEARING	1
8	5002440	RETAINING RING	2
9	5100980	RETAINING RING	1
10	5101180	RETAINING RING	1
11	7681300	O-RING	1
12	9313040	SET SCREW	2
13	9411080	SCREW	4
14	9507100	WASHER	4

MOTOR ASS'Y 42V, 3HP, 3PH, 50HZ, 47.0 AMPS	1703500	2340100	1703350
MOTOR ASS'Y 380V, 3HP, 3PH, 50HZ, 5.1 AMPS	1703520-380-350	2340120	1703350
MOTOR ASS'Y 220V, 3HP, 3PH, 50HZ, 8.8 AMPS	1703520-220-350	2340120	1703350
MOTOR ASS'Y 416V, 3HP, 3PH, 50HZ, 4.3 AMPS	1703530-416-350	2340130	1703350
MOTOR ASS'Y 208V, 3HP, 3PH, 50HZ, 8.6 AMPS	1703530-208-350	2340130	1703350
MOTOR ASS'Y 230V, 3HP, 3PH, 50HZ, 8.8 AMPS	1703510-230-350	2340110	1703350
MOTOR ASS'Y 115V, 3HP, 3PH, 50HZ, 17.6 AMPS	1703510-115-350	2340110	1703350
MOTOR ASS'Y 550V, 3HP, 3PH, 60HZ, 3.8AMPS	1703550	2340150	1703350
MOTOR ASS'Y 380V, 3HP, 3PH, 60HZ, 5.0 AMPS	1703540-380-360	2340140	1703350
MOTOR ASS'Y 220V, 3HP, 3PH, 60HZ, 8.6 AMPS	1703540-220-360	2340140	1703350
MOTOR ASS'Y 460V, 3HP, 3PH, 60HZ, 4.1 AMPS	1703530-460-360	2340130	1703350
MOTOR ASS'Y 230V, 3HP, 3PH, 60HZ, 8.2 AMPS	1703530-230-360	2340130	1703350
<b>MOTOR OPTION DESCRIPTION</b>	<b>MOTOR ASS'Y</b>	<b>STATOR</b>	<b>ROTOR</b>
<b>BM-V: 3HP MOTOR ASSEMBLY OPTIONS with STATOR</b>			

**Figure 23 3HP MOTOR OPTIONS**

1703380	1703370	2340600
Rotor Shaft Ass'y	Motor Shaft	Rotor

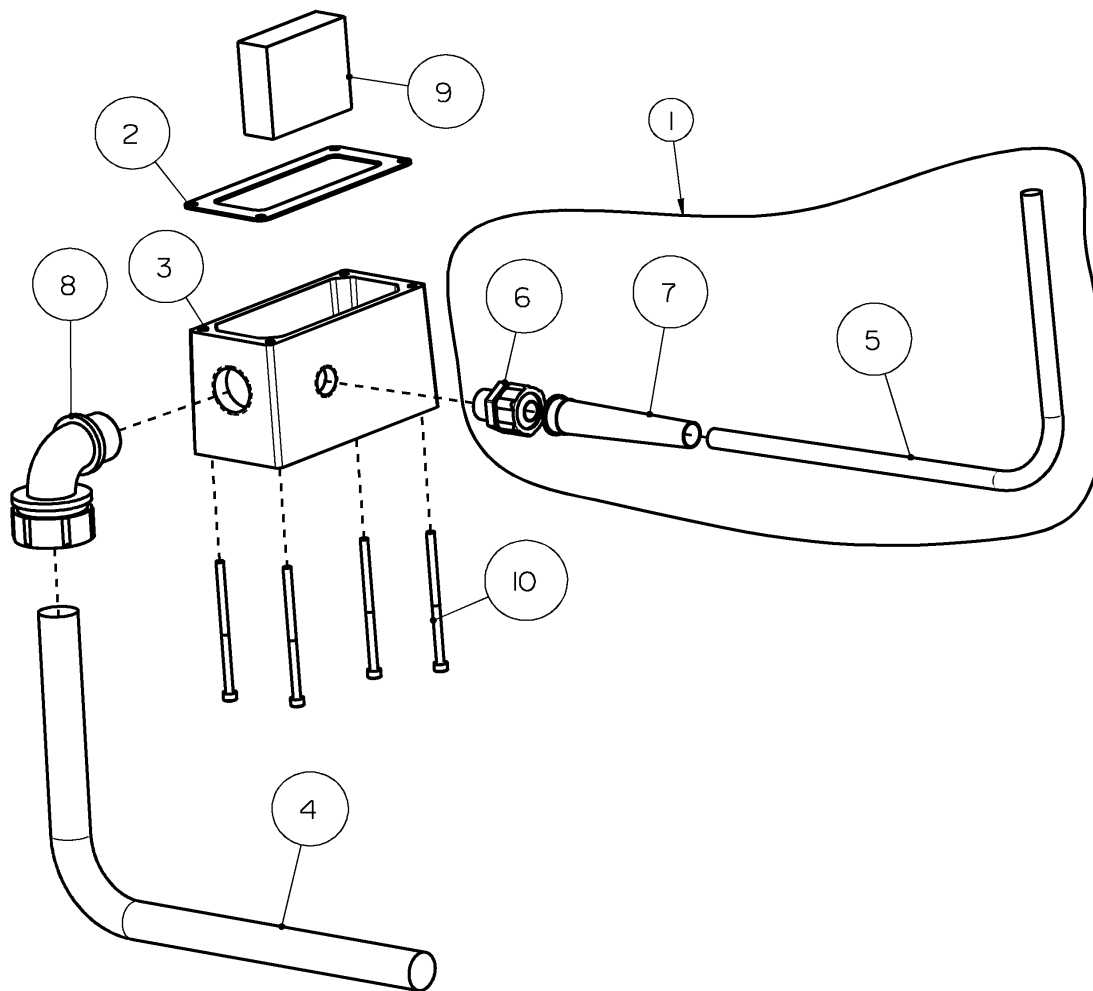


BM-V-5HP MOTOR			
ITEM	PART #	DESCRIPTION	QTY
1	<b>OPTIONS</b>	STATOR, <b>CHART BELOW</b>	1
2	1501840	COVER	1
3	1703380	ROTOR-SHAFT ASSEMBLY	1
4	1703390	MOTOR HOUSING 3HP	1
5	8600680	KEY	1
6	3522060	BEARING	1
7	3524050	BEARING	1
8	5002440	RETAINING RING	2
9	5100980	RETAINING RING	1
10	5101180	RETAINING RING	1
11	7681300	O-RING	1
12	9313040	SET SCREW	2
13	9411080	SCREW	4
14	9507100	WASHER	4

MOTOR ASS'Y 550V, 5HP, 3PH, 60HZ, 5.6 AMPS	1703650	2340050	1703380
MOTOR ASS'Y 380V, 5HP, 3PH, 60HZ, 7.8AMPS	1703640-380-360	2340040	1703380
MOTOR ASS'Y 220V, 5HP, 3PH, 60HZ, 14.7AMPS	1703640-220-360	2340040	1703380
MOTOR ASS'Y 380V, 5HP, 3PH, 50HZ, 7.7 AMPS	1703620-380-350	2340020	1703380
MOTOR ASS'Y 220V, 5HP, 3PH, 50HZ, 13.4 AMPS	1703620-220-350	2340020	1703380
MOTOR ASS'Y 42V, 5HP, 3PH, 50HZ, 73.0 AMPS	1703600	2340000	1703380
MOTOR ASS'Y 460V, 5HP, 3PH, 60HZ, 6.5 AMPS	1703630-460-360	2340030	1703380
MOTOR ASS'Y 230V, 5HP, 3PH, 60HZ, 13.0 AMPS	1703630-230-360	2340030	1703380
MOTOR ASS'Y 230V, 5HP, 3PH, 50HZ, 13.6 AMPS	1703610-230-350	2340010	1703380
MOTOR ASS'Y 115V, 5HP, 3PH, 50HZ, 27.2 AMPS	1703610-115-350	2340010	1703380
<b>MOTOR OPTION DESCRIPTION</b>	<b>MOTOR ASS'Y</b>	<b>STATOR</b>	<b>ROTOR</b>
<b>BM-V: 5HP MOTOR ASSEMBLY OPTIONS with STATOR</b>			

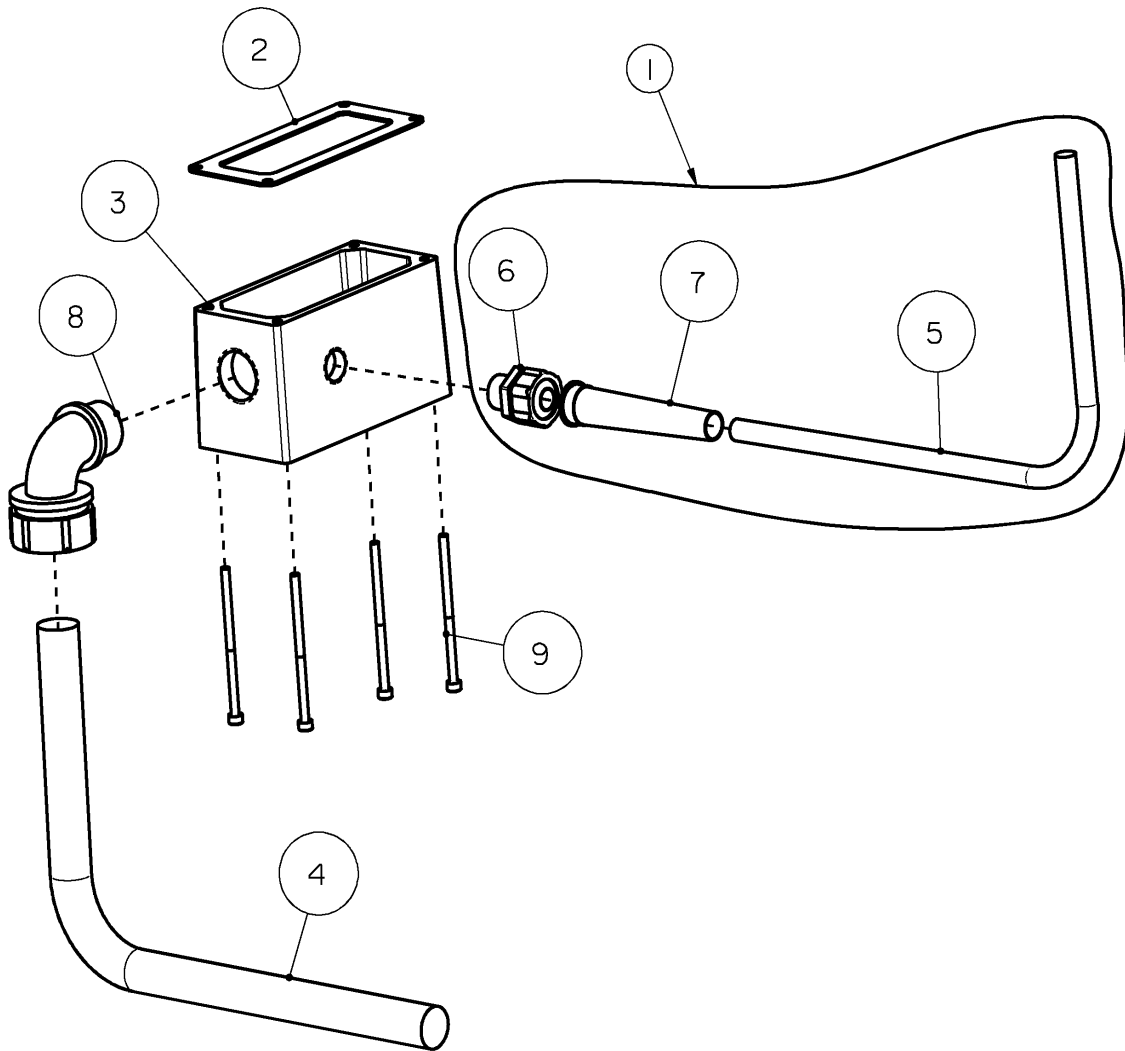
**Figure 24 5HP MOTOR OPTIONS**

**POWER SUPPLY OPTIONS**



<b>1720001 POWER CORD ASS'Y, 42V, ATD</b>			
<b>ITEM</b>	<b>PART #</b>	<b>DESCRIPTION</b>	<b>QTY</b>
1	1002433	POWER CORD ASSEMBLY, 14/3	1
2	1708730	GASKET	1
3	1709461	COVER, WIRE BOX	1
4	2001070	POWER CORD 4/4	1
5	2001260	POWER CORD 14/3	1
6	2008240	CONNECTOR	1
7	2008241	CORD STRAIN RELIEF	1
8	2008250	CONNECTOR	1
9	2009120	TIMER	1
10	9209260	SCREW	4

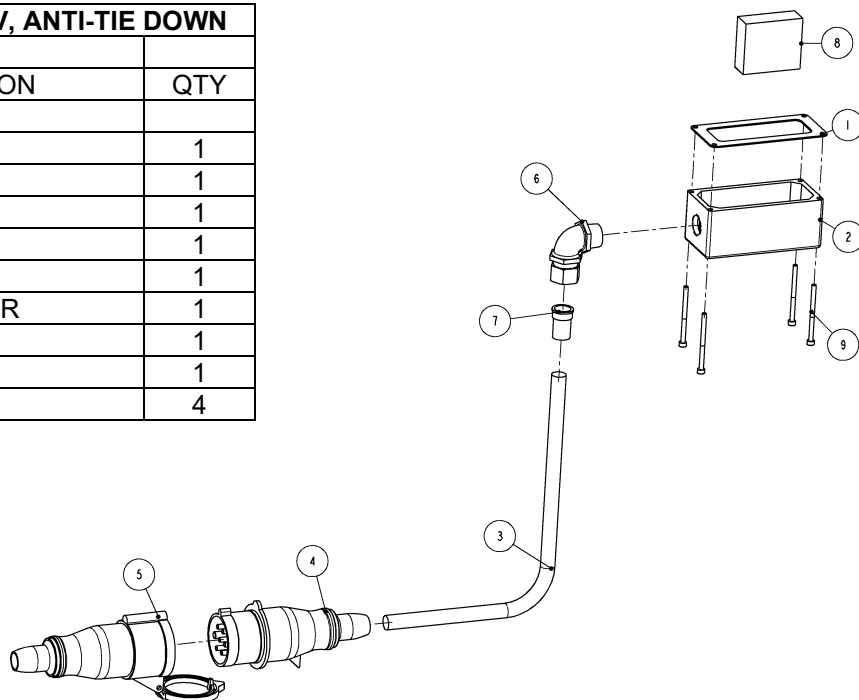
**Figure 25 POWER SUPPLY, 42V, with ANTI-TIEDOWN**



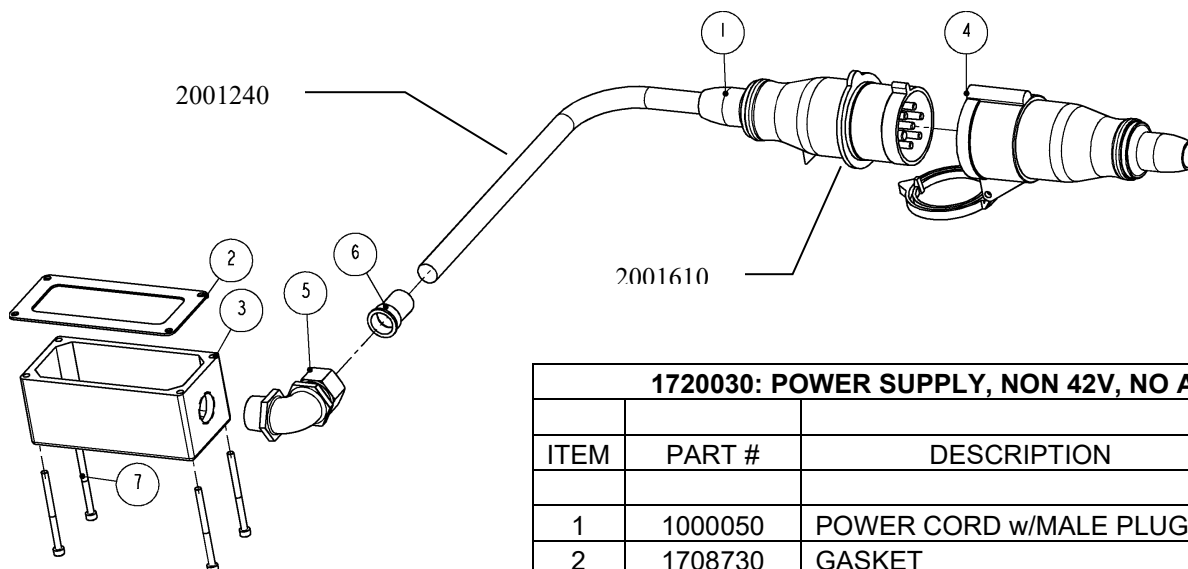
1720002: POWER CORD ASS'Y, 42V			
ITEM	PART #	DESCRIPTION	QTY
1	1002433	POWER CORD ASSEMBLY, 14/3	1
2	1708730	GASKET	1
3	1709461	COVER, WIRE BOX	1
4	2001070	POWER CORD	1
5	2001260	POWER CORD	1
6	2008240	CONNECTOR	1
7	2008241	CORD STRAIN RELIEF	1
8	2008250	CONNECTOR	1
9	9209260	SCREW	4

**Figure 26 POWER SUPPLY, 42V, without ANTI-TIEDOWN**

<b>1720020: POWER SUPPLY, NON 42V, ANTI-TIE DOWN</b>			
ITEM	PART #	DESCRIPTION	QTY
1	1708730	GASKET	1
2	1709460	COVER, WIRE BOX	1
3	2001080	POWER CORD	1
4	2001610	SOCKET, MALE	1
5	2001620	SOCKET, FEMALE	1
6	2008180	CABLE CONNECTOR	1
7	2008220	CORD GRIP	1
8	2009120	TIMER	1
9	9209240	SCREW	4



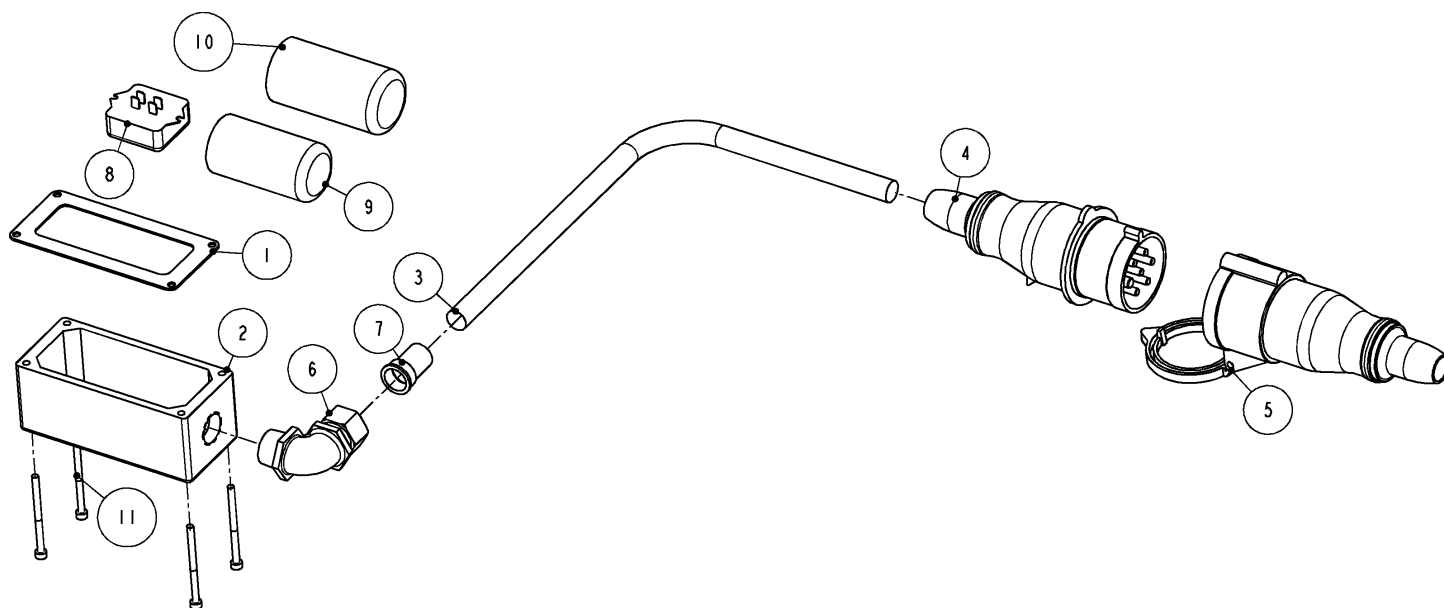
**Figure 27 POWER SUPPLY, NON 42V, with ANTI-TIEDOWN**



<b>1720030: POWER SUPPLY, NON 42V, NO ATD</b>			
ITEM	PART #	DESCRIPTION	QTY
1	1000050	POWER CORD w/MALE PLUG	1
2	1708730	GASKET	1
3	1709460	COVER, WIRE BOX	1
4	2001620	SOCKET, FEMALE	1
5	2008180	CABLE CONNECTOR	1
6	2008220	CORD GRIP	1
7	9209240	SCREW	4

POWER CORD 1000050: POWER CORD 20 FT LONG (2001240) + MALE PLUG (2001610)

**Figure 28 POWER SUPPLY, NON 42V, without ANTI-TIEDOWN**

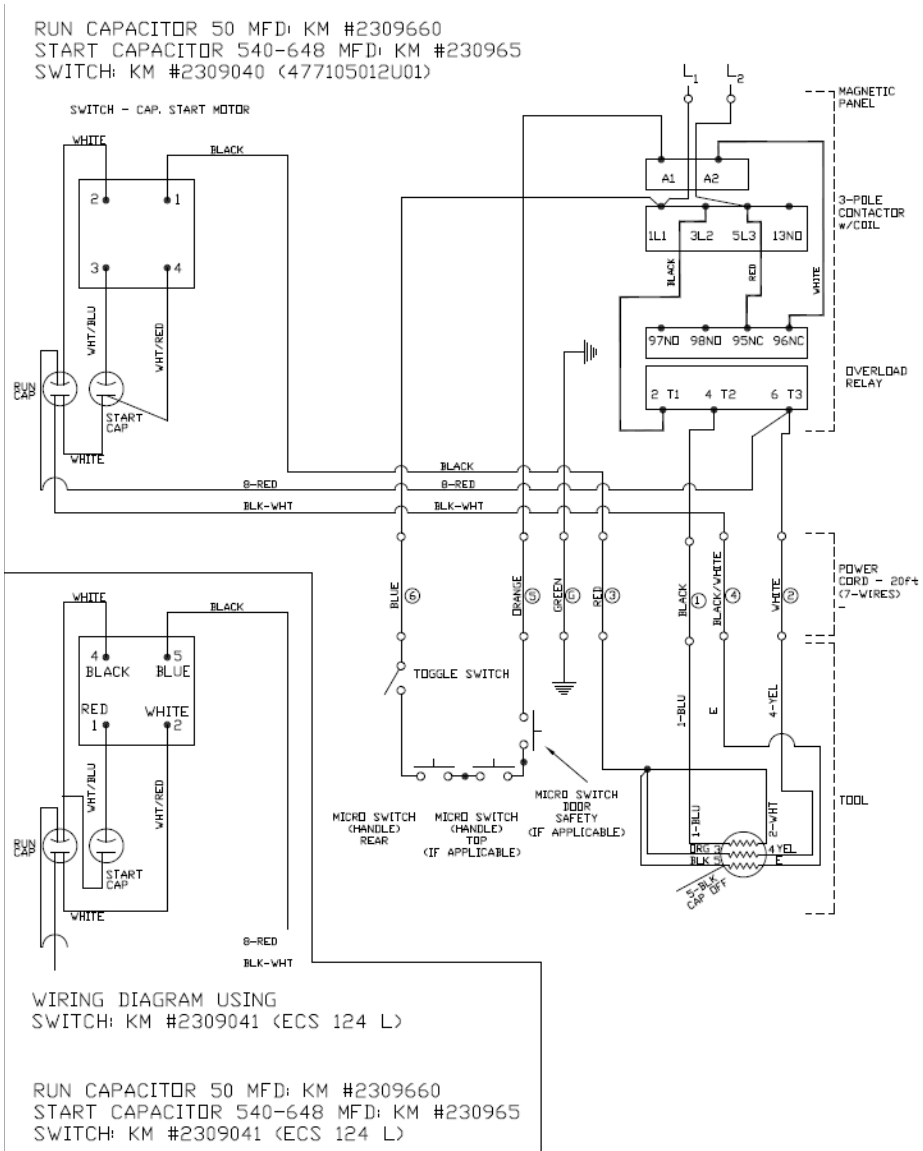


<b>1720007: POWER SUPPLY, SINGLE PHASE 115 / 230V</b>			
<b>ITEM</b>	<b>PART #</b>	<b>DESCRIPTION</b>	<b>QTY</b>
1	1708730	GASKET	1
2	1709460	COVER, WIRE BOX	1
3	2001080	POWER CORD	1
4	2001610	PLUG, MALE	1
5	2001620	SOCKET, FEMALE	1
6	2008180	CABLE CONNECTOR	1
7	2008220	CORD GRIP	1
8	2309040	SWITCH SINPAC (OPTION 1)	1
8	2309041	SWITCH ECL (OPTION 2)	1
9	2309650	START CAPACITOR – 540-648 MFD	1
10	2309660	RUN CAPACITOR – 50MFD	1
11	9209240	SCREW	4

**Figure 29 POWER SUPPLY, SINGLE PHASE, 115 / 230V**



## WIRING DIAGRAMS



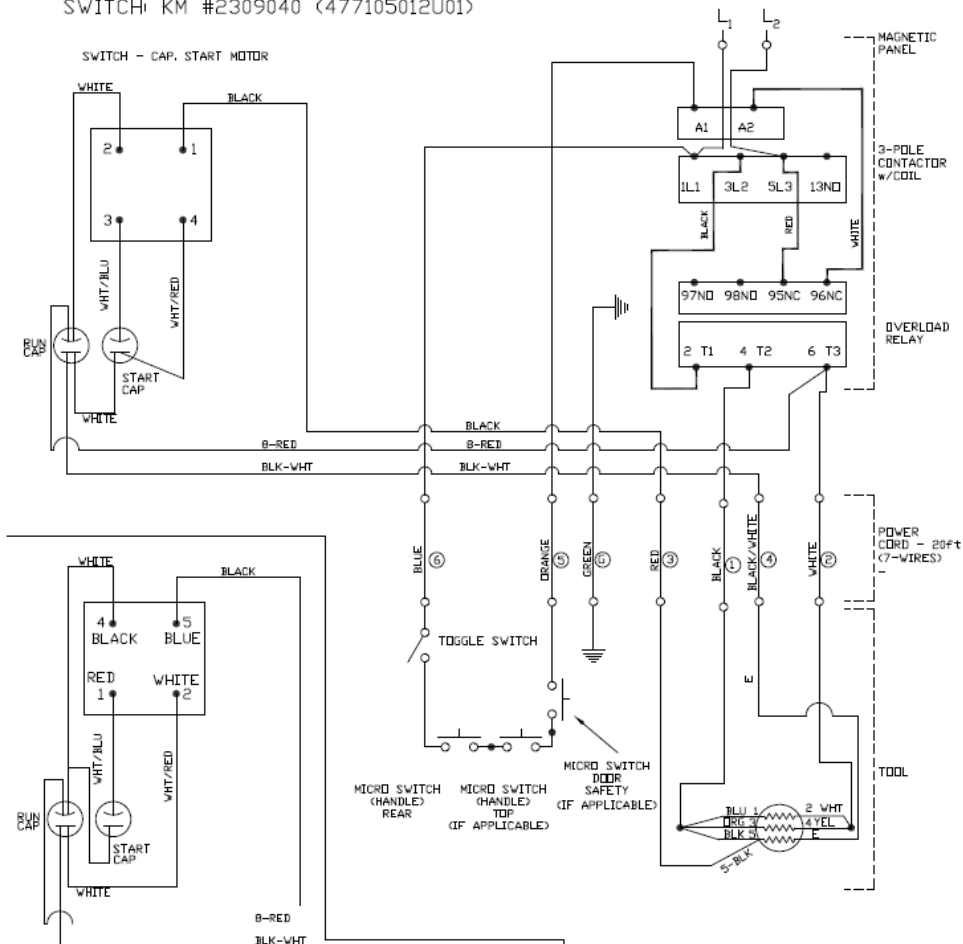
SINGLE PHASE – 230V			
CONTROL VOLTAGE	MOTOR OPTION	3-POLE CONTACTOR	OVERLOAD RELAY
220V	MOTOR 220V, 60HZ, 11.7AMPS, 2HP	2020033	2309170
220V	MOTOR 220V, 50HZ, 12.2AMPS, 2HP	2020033	2309170

**NOTES:**

1. DO NOT ATTEMPT OR MAKE REPAIRS ON THE MACHINE WHILE POWER IS ON.
2. ALL ELECTRICAL WORK MUST BE PERFORMED BY A QUALIFIED ELECTRICIAN.
3. THE CAPACITOR AND THE SWITCH – CAP. START MOTOR ARE MOUNTED INSIDE THE MAGNETIC PANEL BOX.
4. THE ELECTRICAL DIAGRAM SHOWS THE MACHINE IN THE “OFF” POSITION.
5. THE GROUND WIRE (GREEN) OF THE POWER CABLE IS CONNECTED TO THE FRAME OF THE MACHINE.
6. TO REVERSE DIRECTION, REVERSE MOTOR WIRES #5 AND #8.

**Figure 30 WIRING DIAGRAM – SINGLE PHASE – 230V**

RUN CAPACITOR 50 MFD: KM #2309660  
 START CAPACITOR 540-648 MFD: KM #230965  
 SWITCH: KM #2309040 (477105012U01)



WIRING DIAGRAM USING  
 SWITCH: KM #2309041 (ECS 124 L)

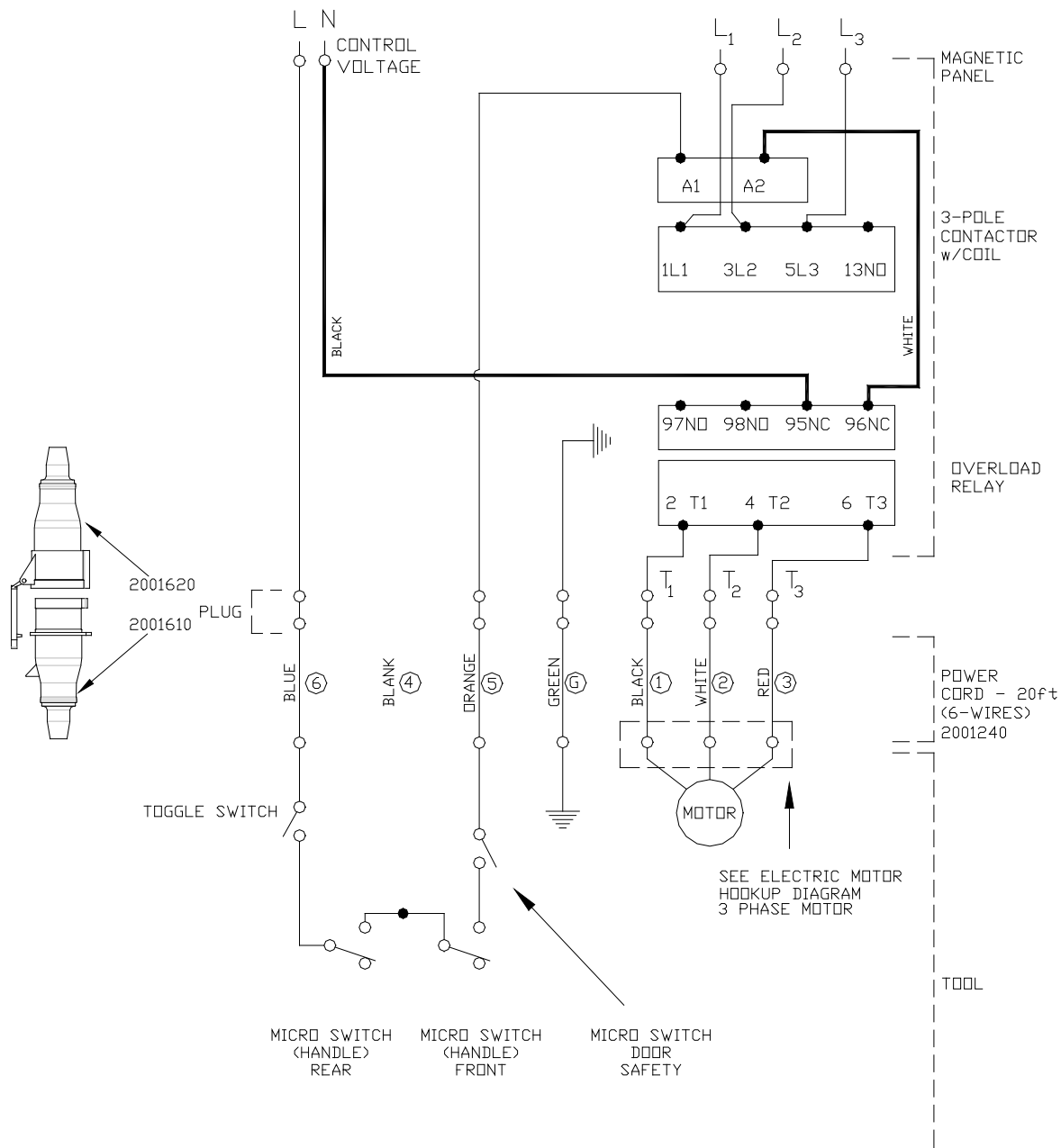
RUN CAPACITOR 50 MFD: KM #2309660  
 START CAPACITOR 540-648 MFD: KM #230965  
 SWITCH: KM #2309041 (ECS 124 L)

SINGLE PHASE – 115V			
CONTROL VOLTAGE	MOTOR OPTION	3-POLE CONTACTOR	OVERLOAD RELAY
115V	MOTOR 115V, 60HZ, 23.4AMPS, 2HP	2020038	2309200
115V	MOTOR 115V, 50HZ, 24.4AMPS, 2HP	2020038	2309200

NOTES:

- DO NOT ATTEMPT OR MAKE REPAIRS ON THE MACHINE WHILE POWER IS ON.
- ALL ELECTRICAL WORK MUST BE PERFORMED BY A QUALIFIED ELECTRICIAN.
- THE CAPACITOR AND THE SWITCH – CAP. START MOTOR ARE MOUNTED INSIDE THE MAGNETIC PANEL BOX.
- THE ELECTRICAL DIAGRAM SHOWS THE MACHINE IN THE “OFF” POSITION.
- THE GROUND WIRE (GREEN) OF THE POWER CABLE IS CONNECTED TO THE FRAME OF THE MACHINE.
- TO REVERSE DIRECTION, REVERSE MOTOR WIRES #5 AND #8.

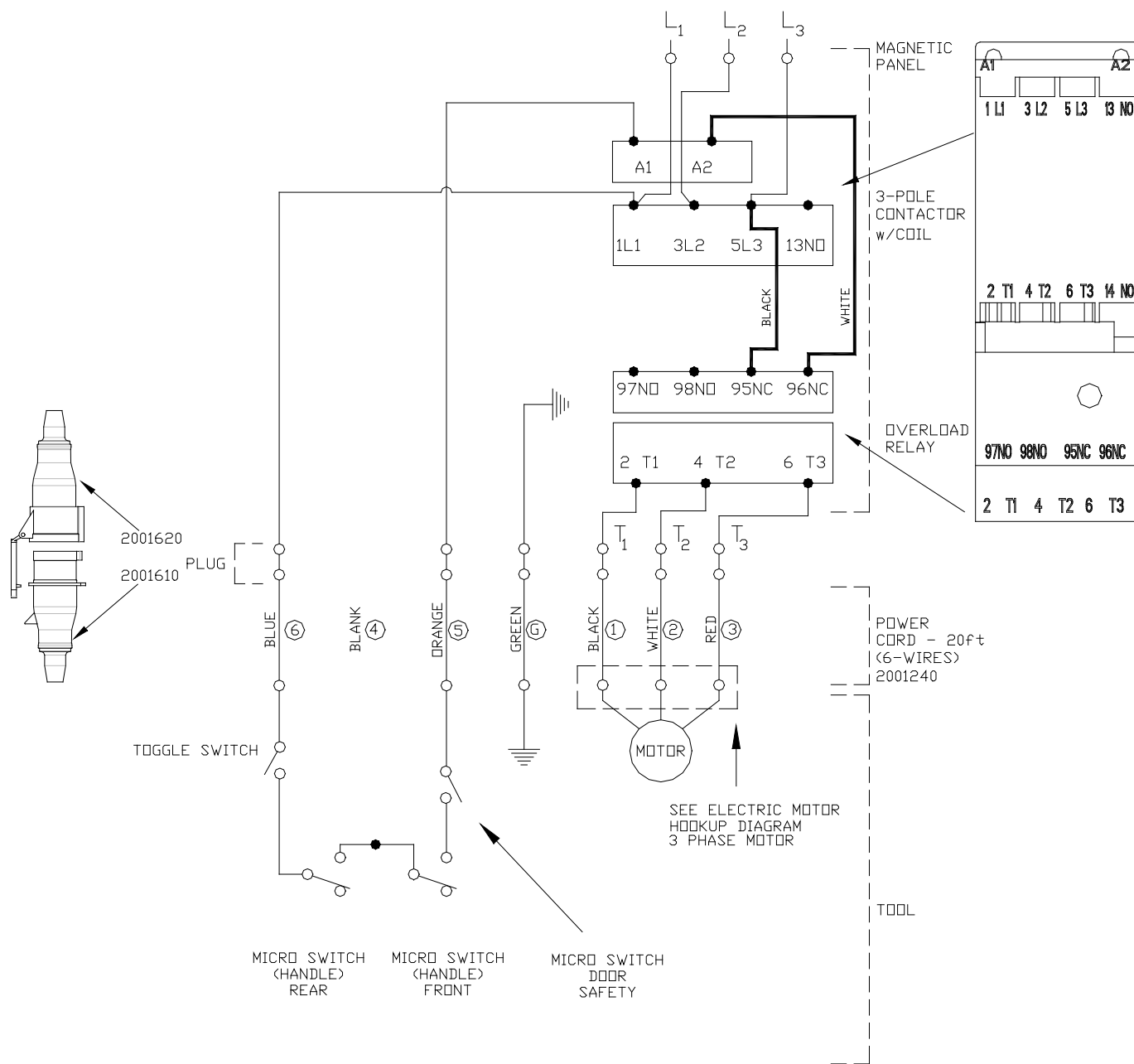
**Figure 31 WIRING DIAGRAM – SINGLE PHASE – 115V**



1. DO NOT ATTEMPT OR MAKE REPAIRS ON THE MACHINE WHILE POWER IS ON.
2. ALL ELECTRICAL WORK MUST BE PERFORMED BY A QUALIFIED ELECTRICIAN.
3. THE ELECTRICAL DIAGRAM SHOWS THE MACHINE IN THE "OFF" POSITION.

**To obtain the correct Kentmaster part number for 3-pole contactor and overload relay, please contact the Kentmaster representative.**

**Figure 32 WIRING DIAGRAM – 3 PHASE – DIFFERENT CONTROL AND MOTOR VOLTAGE – without Anti-Tie Down**



1. DO NOT ATTEMPT OR MAKE REPAIRS ON THE MACHINE WHILE POWER IS ON.
2. ALL ELECTRICAL WORK MUST BE PERFORMED BY A QUALIFIED ELECTRICIAN.
3. THE ELECTRICAL DIAGRAM SHOWS THE MACHINE IN THE “OFF” POSITION.

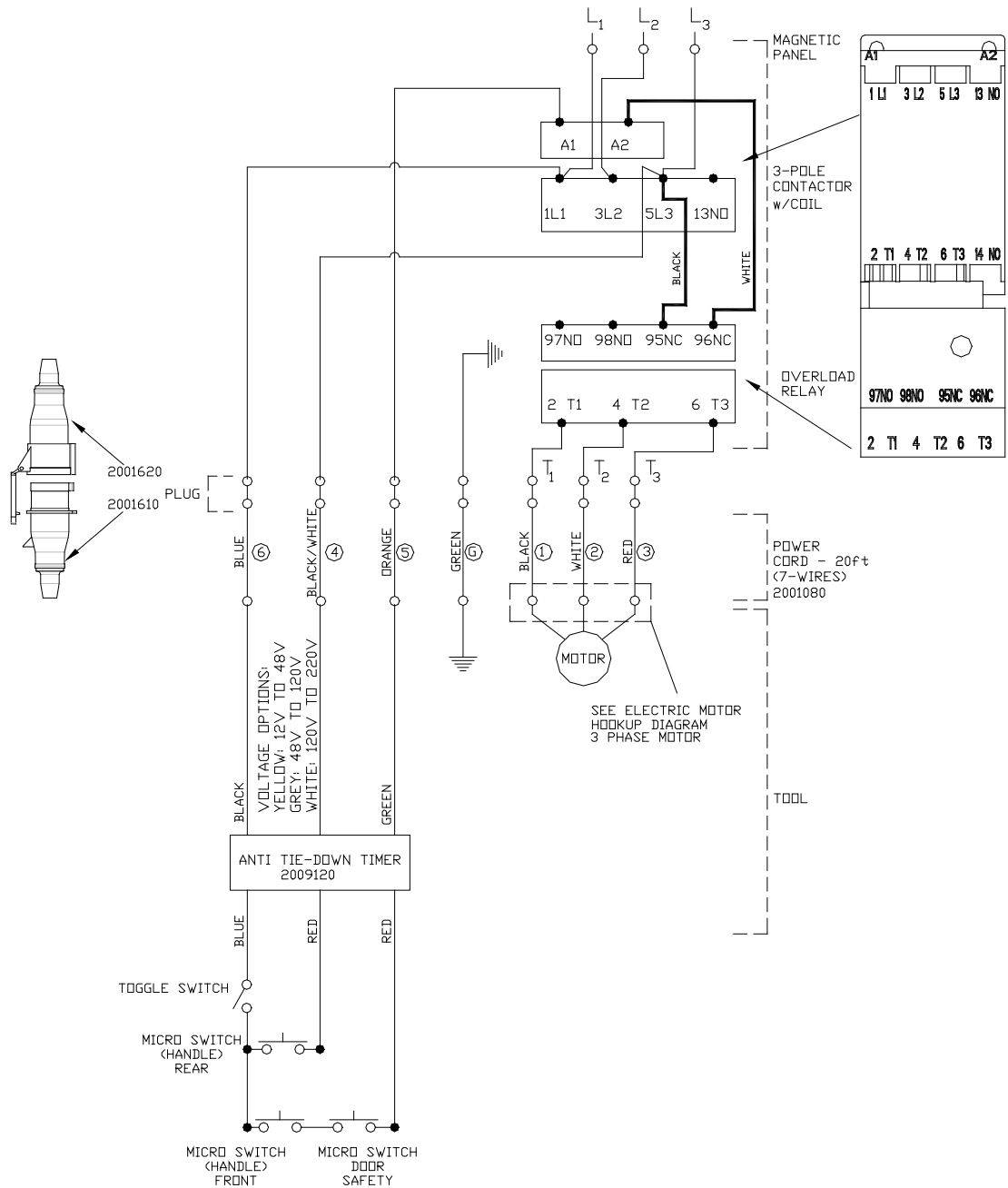
**To obtain the correct Kentmaster part number for 3-pole contactor and overload relay, please contact the Kentmaster representative.**

**Figure 33 WIRING DIAGRAM – 3 PHASE – SAME CONTROL AND MOTOR VOLTAGE –without Anti-Tie Down**

1. DO NOT ATTEMPT OR MAKE REPAIRS ON THE MACHINE WHILE POWER IS ON.
2. ALL ELECTRICAL WORK MUST BE PERFORMED BY A QUALIFIED ELECTRICIAN.
3. THE ELECTRICAL DIAGRAM SHOWS THE MACHINE IN THE "OFF" POSITION.

**To obtain the correct Kentmaster part number for 3-pole contactor and overload relay, please contact the Kentmaster representative.**

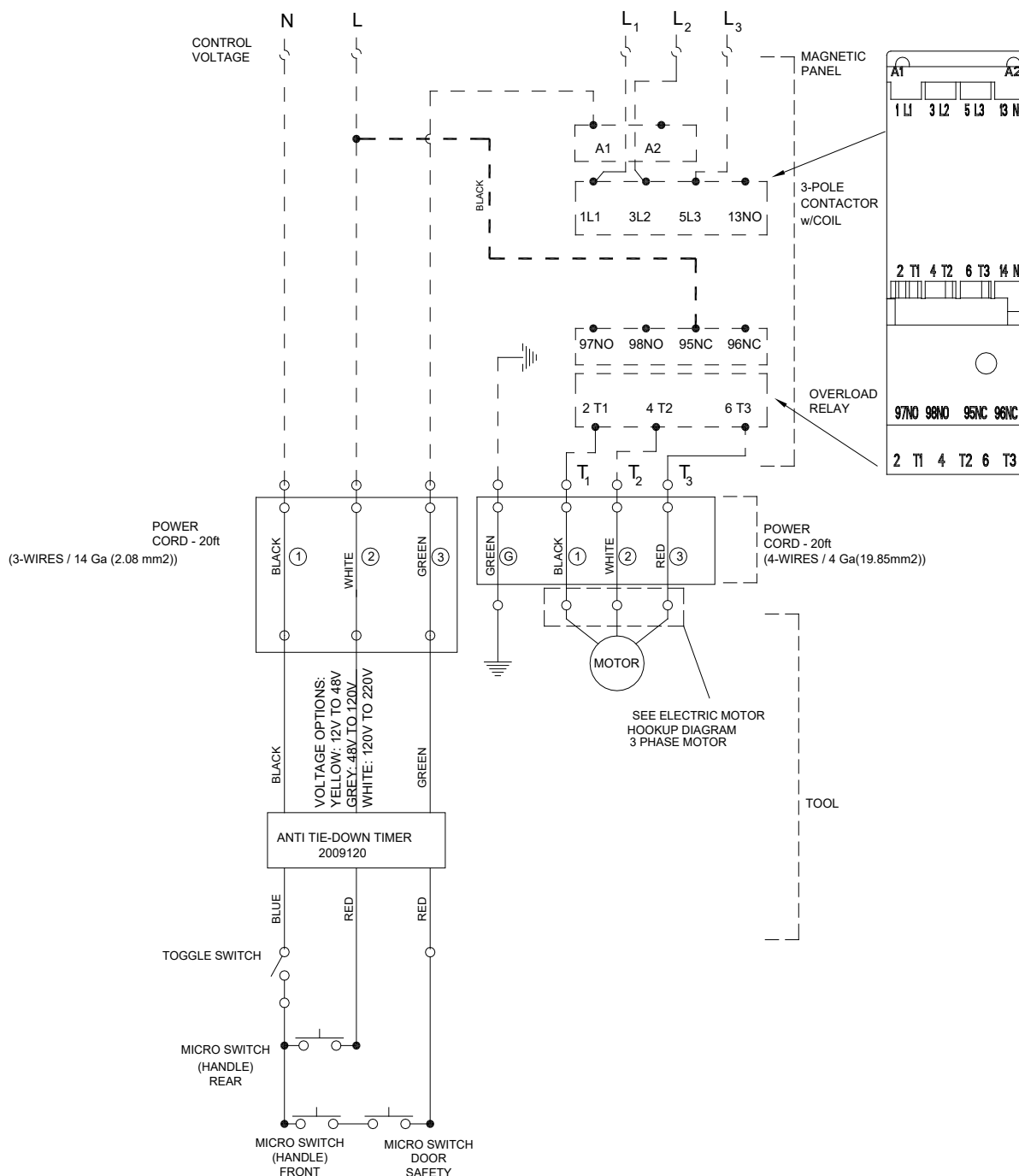
**Figure 34 WIRING DIAGRAM – 3 PHASE – DIFFERENT CONTROL AND MOTOR VOLTAGE – with Anti-Tie Down**



1. DO NOT ATTEMPT OR MAKE REPAIRS ON THE MACHINE WHILE POWER IS ON.
2. ALL ELECTRICAL WORK MUST BE PERFORMED BY A QUALIFIED ELECTRICIAN.
3. THE ELECTRICAL DIAGRAM SHOWS THE MACHINE IN THE "OFF" POSITION.

**To obtain the correct Kentmaster part number for 3-pole contactor and overload relay, please contact the Kentmaster representative.**

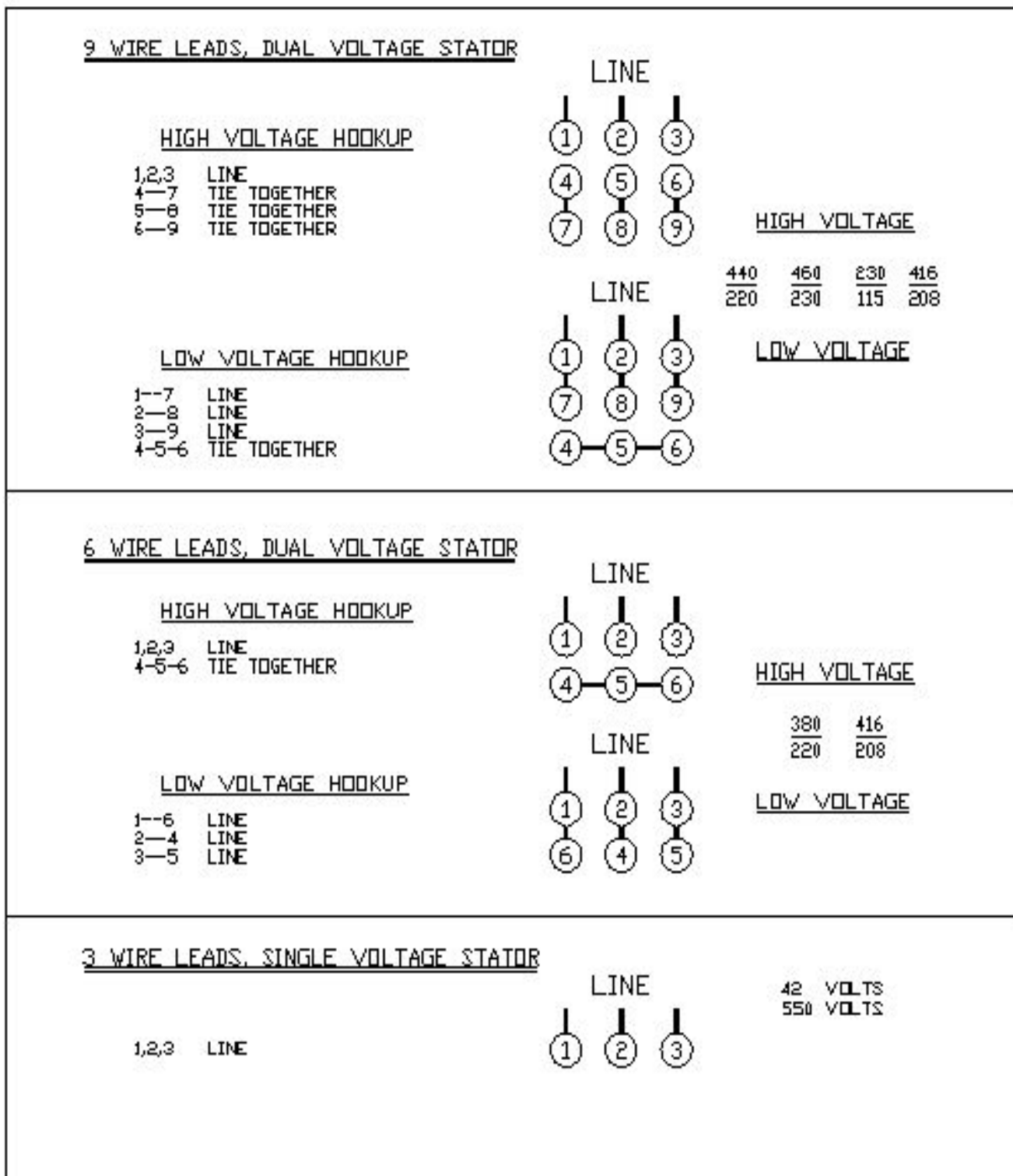
**Figure 35 WIRING DIAGRAM – 3 PHASE – SAME CONTROL/TRIGGER AND MOTOR VOLTAGE  
with Anti-Tie Down**



4. DO NOT ATTEMPT OR MAKE RAPAIRS ON THE MACHINE WHILE POWER IS ON.
5. ALL ELECTRICAL WORK MUST BE PERFORMED BY A QUALIFIED ELECTRICIAN.
6. THE ELECTRICAL DIAGRAM SHOWS THE MACHINE IN THE “OFF” POSITION.

**To obtain the correct Kentmaster part number for 3-pole contactor and overload relay, please contact the Kentmaster representative.**

**Figure 36 WIRING DIAGRAM – 3 PHASE – 42V Motor option - with Anti-Tie Down**

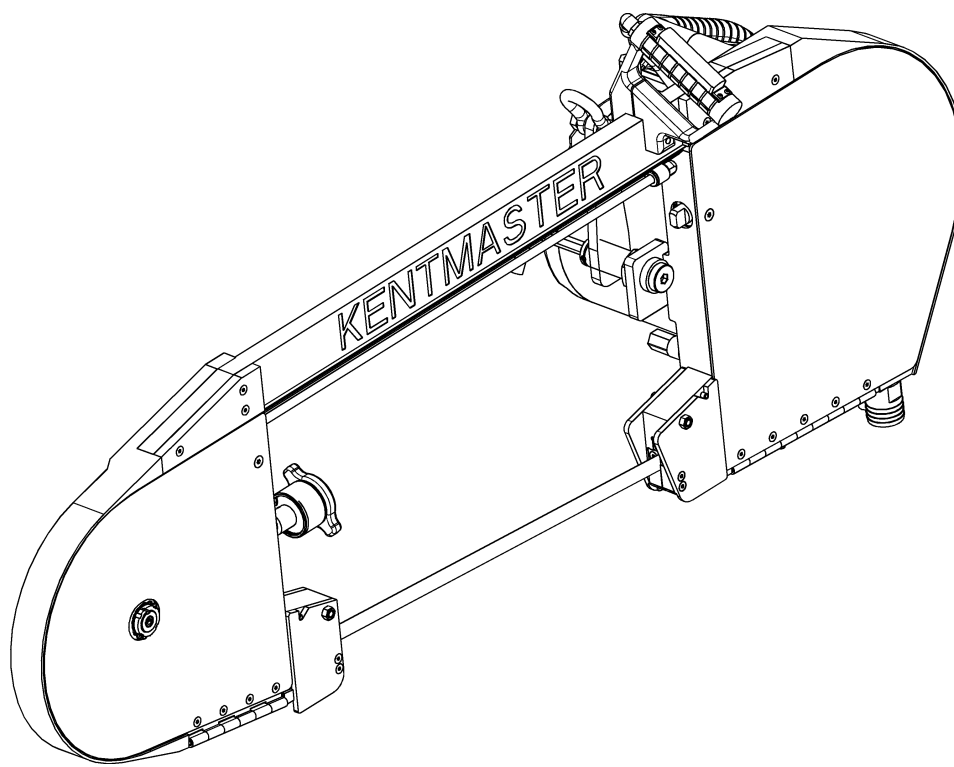


**Figure 37 ELECTRIC MOTOR LEAD HOOKUP DIAGRAM 3 PHASE MOTOR**



[ENGLISH]

## GENERAL INFORMATION



### MODELS

**BM-V-SB CARCASS SPLITTING SAW (1708050)**  
**BM-V-S CARCASS SPLITTING SAW (1708000)**  
**BM-V-SD CARCASS SPLITTING SAW (1708100)**  
**BM-V-SDB CARCASS SPLITTING SAW (1730000)**

### SERVICE CENTERS

**KENTMASTER LTD. (U.K)**  
16 AVONBANK INDUSTRIAL CENTRE  
WEST TOWN ROAD  
AVONMOUTH - BRISTOL BS11 9DE  
UNITED KINGDOM

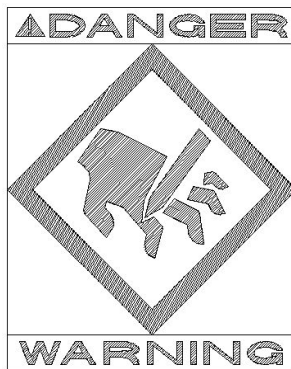
☎ TELEPHONE: ++ 44- (0) 117- 9235035  
FAX: ++ 44- (0) 117- 9829010

**KENTMASTER MFG. CO., INC.**  
1801 SOUTH MOUNTAIN AVE.  
MONROVIA, CALIFORNIA 91016  
UNITED STATES OF AMERICA

☎ TELEPHONE: (626) 359-8888  
FAX: (626) 303-5151

**NOTICE TO EMPLOYER AND PURCHASER OF TOOL**  
**NOTICE TO SAFETY DIRECTOR**

**You have purchased a powerful tool that, if misused, can cause severe injury and harm to your employees. You must instruct your employees in the safe and proper use of this tool and to follow the safety procedures and instructions that have been supplied by the manufacturer of this tool. Please follow the following instructions.**



1. Instruct tool operators to test the tool each day before using it to be sure it does not malfunction. Remove and repair any tool that malfunctions.
2. Instruct tool operators to immediately stop using a tool that malfunctions or is defective.
3. Instruct personnel to immediately remove all tools that malfunction. Be sure to disconnect tool from power supply.
4. Instruct all personnel to stay clear of tool, and not to stand or walk in front of, or next to tool when in use.
5. Point out to all personnel the dangers related to the misuse of tool and the importance of following safety procedures and instructions.
6. Do not make, or allow others to make, alterations or modifications to this tool. Replace all lost or illegible labels.
7. Follow all safety, installation and maintenance instructions provided with this tool. Establish proper safety procedures in accordance with local and national requirements to prevent accidental energizing of tool that can cause injuries.
8. If this tool is sold or change in ownership takes place, you must provide the new owner all safety instructions, notices and maintenance instructions you were originally provided. You can obtain additional copies of the instructions from Kentmaster, free of charge upon request.
9. Give copies of instructions to:
  - (A) Tool Operators**
  - (B) Maintenance Supervisor**
  - (C) Clean-up Supervisor**

## GENERAL INFORMATION

COVERING: SAFETY PRECAUTIONS AND PLACING INTO SERVICE  
**ELECTRICAL POWERED CARCASS SPLITTING SAW**

**READ THIS MANUAL CAREFULLY BEFORE INSTALLING, OPERATING OR SERVICING THIS TOOL**

IT IS THE RESPONSIBILITY OF THE EMPLOYER TO PLACE THIS INFORMATION INTO THE HANDS OF THE OPERATOR.

### PLACING INTO SERVICE

 **WARNING**

= Hazards or unsafe practices which could result in severe personal injury, death or substantial property damage.

 **CAUTION**

= Hazards or unsafe practices which could result in minor personal injury, product or property damage.

 **NOTICE**

= Important installation, operation or maintenance information.

 **WARNING**

Installation, adjustment repair and maintenance of this tool must be made by trained and qualified personnel.

 **WARNING**

Always disconnect power supply from tool before:

- (A) Installing or removing blade from tool.
- (B) Making repairs or adjustments to the tool.
- (C) performing maintenance or cleanup work.

## INSTALLATION INSTRUCTIONS

 **WARNING**

**ALL ELECTRICAL WIRING MUST BE DONE BY A LICENSED ELECTRICIAN IN ACCORDANCE WITH THE NATIONAL, STATE AND LOCAL ELECTRICAL CODES. (REFER TO NAMEPLATE ON TOOL FOR PROPER POWER CONFIGURATION).**

1. A BALANCER IS REQUIRED FOR OPERATION AND USE OF THIS TOOL. WEIGHT OF TOOL MUST FALL WITHIN WEIGHT RANGE OF BALANCER. "AIR-BALANCERS" WHICH OPERATE ON COMPRESSED AIR, ARE HIGHLY RECOMMENDED FOR USE WITH BANDMASTER SAWS. THEY PROVIDE LONG TRAVEL AND VERY SMOOTH, UNIFORM RISE AND FALL. THEY CAN BE INTERFACED WITH THE OPERATION OF THE SAW.
2. INSTALL BALANCER ABOVE WORK AREA. BALANCER MUST HAVE SUFFICIENT VERTICAL TRAVEL SO OPERATOR CAN REACH ENTIRE WORK AREA WITH TOOL WITHOUT STRAIN.
3. ADJUST BALANCER ACCORDING TO THE OPERATOR'S PREFERENCE AND COMFORT.
4. TOOL REQUIRES GREASING AFTER EVERY 40 HOURS OF OPERATION. GREASE USING KENTMASTER GREASE (PART NO. 7903070).

 **WARNING**

**WE STRONGLY SUGGEST THAT AN ADDITIONAL SAFETY CHAIN BE USED TO CHAIN BALANCER TO OVERHEAD TROLLEY. THIS ADDITIONAL MEASURE OF SAFETY WILL HELP REDUCE INJURIES.**

## OPERATING INSTRUCTIONS

**⚠ WARNING ONLY TRAINED PERSONNEL ARE TO OPERATE THIS TOOL.**

1. HOLD TOOL FIRMLY AT BOTH TRIGGER HANDLES. SQUEEZE TRIGGERS SIMULTANEOUSLY TO ACTIVATE TOOL.
2. START CUT WITH SAW NOSE POINTED UP AT AN ANGLE.
3. LEVEL SAW TO HORIZONTAL POSITION IN LOIN AREA.
4. POINT NOSE OF SAW AT DOWNWARD ANGLE IN CHUCK AND NECK AREA.
5. A BEGINNING SPLITTER CAN MARK BACKFAT OF BEEF WITH A KNIFE TO HELP GUIDE SAW DOWN CENTER OF BACKBONE AND UNTIL OPERATOR IS FAMILIAR WITH SPLITTING PROCEDURE.
6. DO NOT EXERT EXCESSIVE PRESSURE. ALLOW TIME FOR THE TOOL TO CUT.
7. PUSH SAW FORWARD SO THAT GUARDS, ITEMS 1 AND 2, FIGURE 1, RIDE AGAINST BEEF. THIS HELPS STEADY SAW IN CUT AND HELPS ELIMINATE BLADE JUMPING AND CHATTERING.

## MAINTENANCE

**⚠ WARNING ONLY TRAINED AND QUALIFIED PERSONNEL ARE TO PERFORM MAINTENANCE AND SERVICE TO THIS TOOL.**

1. FOLLOW PROCEDURE NO. 4 OF INSTALLATION INSTRUCTIONS.

## BLADE REMOVAL AND CLEANING.

**⚠ WARNING ALWAYS DISCONNECT POWER SUPPLY FROM TOOL BEFORE INSTALLING OR REMOVING BLADE FROM TOOL.**

**⚠ WARNING ALWAYS WEAR WIRE MESH GLOVES WHEN INSTALLING OR REMOVING BLADES FROM TOOL.**

1. REMOVE PAPER WRAPPER FROM BLADE.
2. OPEN COVERS, FIGURE 1, ITEMS 3 AND 4.
3. INSTALL TORQUE WRENCH INTO SCREW, FIGURE 1, ITEM 5, AND TURN COUNTER-CLOCKWISE (CCW). THIS ALLOWS TAKE-UP WHEEL AND SLIDE, ITEM 7 AND 8, TO RETRACT.
4. SLIDE TAKE-UP WHEEL TO RIGHT.
5. HOLD BLADE, WITH TEETH FACING AWAY FROM YOU, AND INSTALL INTO SLOT OF BEAM, CONTINUING AROUND AND OVER THE TAKE-UP AND DRIVE WHEELS.
6. TURN TORQUE WRENCH CLOCKWISE (CW) TO ELIMINATE BLADE SLACK AND TIGHTEN TAKE-UP WHEEL AGAINST BLADE (TORQUE WRENCH IS PRESET AT FACTORY AND WILL SLIP AFTER PLACING PROPER TENSION ON BLADE).
7. TWIST BLADE 90 DEGREES AT BLADE GUARDS AND INSERT BLADE INTO SLOTS WITH TEETH FACING DOWNWARD.
8. TURN DRIVE WHEEL, ITEM 9, SLOWLY BY HAND, ONE OR TWO TURNS TO CHECK TRACKING OF BLADE ON WHEELS.
9. RETORQUE AGAIN UNTIL TORQUE WRENCH SLIPS.

## SERVICE

1. KEEP GOOD RECORDS OF ALL SERVICE ACTIVITY AND INCLUDE TOOL IN YOUR PREVENTIVE MAINTENANCE PROGRAM.
2. USE ONLY GENUINE KENTMASTER REPLACEMENT PARTS TO ASSURE PROPER PERFORMANCE OF TOOL.
3. CONTACT THE KENTMASTER SUPPLIER NEAREST YOU FOR PARTS AND CUSTOMER SERVICE INFORMATION.

## Kentmaster Worldwide Location

Kentmaster Equipment (Aust) PTY.LTD.  
Unit 2,24 Central Court  
Browns Plains Qld. 4118  
Australia

Telephone: (07) 3806-8400  
Fax: (07) 3806-7933  
Australia@Kentmaster.com

Kentmaster do Brasil, Ltda.  
Av. Dr. Joao Teodoro No. 805  
Bairro De Vila Rezende  
13405-240 Piracicaba, SP,  
Brazil

Telephone #1: (019) 3 413 3113  
Telephone #2: (019)983-4973  
Fax: (019) 3 413 3113  
Brazil@Kentmaster.com

Kentmaster (IRL) LTD.  
Benamore, Dublin Road.  
Roscrea,  
CO, Tipperary,  
Ireland

Telephone: (353) 0505-23292  
Fax: (353) 0505-23299  
Ireland@Kentmaster.com

Kentmaster Equipment (NZ) LTD.  
5 Cooper Street  
Havelock North  
New Zealand

Telephone #1: (64) 6 8777 857  
Telephone #2: 0800 KENTMASTER  
Fax: (64) 6 8777 858  
NewZealand@Kentmaster.com

Kentmaster South Africa (PTY) LTD.  
Johannesburg - S. Africa  
Unit 54 Sunnyrock Park  
Sunrock Close, Germiston  
South Africa

Telephone: (27) 11-455-3748  
Fax: (27) 11-455-3749  
SouthAfrica@Kentmaster.com

Kentmaster (UK ) LTD.  
Unit 16 Avonbank Ind. Centre  
West Town Rd, Avonmouth-Bristol,  
BS11 9DE  
England

Telephone: (44) 117-923-5035  
Fax: (44)-117-932-9010  
UK@Kentmaster.com

Kentmaster Mfg. Co., Inc.  
1801 South Mountain Ave.  
Monrovia, CA, 91016  
USA

Telephone #1: (626) 359-8888  
Telephone #2: (800) 421-1477  
Fax: (626) 303-5151  
info@Kentmaster.com

Kentmaster Omaha  
4417 South 139th Street  
Omaha, NE, 68137  
USA

Telephone #1: (402) 896-3355  
Telephone #2: (800) 367-3181  
Fax: (402) 896-3311  
Omaha@Kentmaster.com

KENTMASTER ARGENTINA SA  
San Lorenzo 3501, Olivos (1636) Buenos Aires Argentina  
+54 11 47900044  
www.kentmaster.com.ar

## INDEX

<b><i>OPERATING AND SAFETY INSTRUCTIONS</i></b> .....	<b>2</b>
<b>OPERATING INSTRUCTIONS</b> .....	<b>3</b>
<b>MAINTENANCE</b> .....	<b>3</b>
<b>CLEANING AND STERILIZING SAW</b> .....	<b>4</b>
<b>WATER CONNECTION</b> .....	<b>4</b>
<b>TORQUE WRENCH CALIBRATION</b> .....	<b>4</b>
<b>HANGER</b> .....	<b>5</b>
<b><i>TROUBLE SHOOTING HINTS:</i></b> .....	<b>6</b>
<b><i>SERVICE</i></b> .....	<b>7</b>
<b><i>PARTS BOOKMODELS</i></b> .....	<b>7</b>
<b><i>MAIN ASSEMBLIES</i></b> .....	<b>7</b>
<b>DRIVE WHEEL ASSEMBLY</b> .....	<b>14</b>
<b>TAKE-UP SIDE ASSEMBLY</b> .....	<b>15</b>
<b>DRIVE SIDE ASSEMBLY</b> .....	<b>17</b>
<b>BLADE GUIDE ASSEMBLY, TAKE-UP SIDE</b> .....	<b>20</b>
<b>BLADE GUIDE ASSEMBLY, DRIVE SIDE</b> .....	<b>22</b>
<b>ADDITIONAL SPRAY OPTIONS</b> .....	<b>23</b>
<b>HANDLES</b> .....	<b>24</b>
<b>MOTOR ASSEMBLY</b> .....	<b>25</b>
<b>POWER SUPPLY OPTIONS</b> .....	<b>29</b>
<b><i>WIRING DIAGRAMS</i></b> .....	<b>33</b>
<b><i>NOTICE TO EMPLOYER AND PURCHASER OF TOOL</i></b> .....	<b>42</b>
<b><i>GENERAL INFORMATION</i></b> .....	<b>43</b>
<b>INSTALLATION INSTRUCTIONS</b> .....	<b>43</b>
<b>OPERATING INSTRUCTIONS</b> .....	<b>44</b>
<b>MAINTENANCE</b> .....	<b>44</b>
<b>SERVICE</b> .....	<b>44</b>
<b><i>Kentmaster Worldwide Location</i></b> .....	<b>45</b>
<b><i>INDEX</i></b> .....	<b>46</b>
<b><i>FIGURES - INDEX</i></b> .....	<b>47</b>

**FIGURES - INDEX**

Figure 1 BM-V- .....	5
Figure 2 MODELS BM-V-SDB AND BM-V-SD.....	8
Figure 3 BOM FOR MODELS BM-V-SDB AND BM-V-SD .....	9
Figure 4 MODEL BM-V-S .....	10
Figure 5 BOM FOR MODEL BM-V-S .....	11
Figure 6 MODEL BM-V-SB .....	12
Figure 7 BOM FOR MODEL BM-V-SB.....	13
Figure 8 DRIVE WHEEL ASSEMBLY .....	14
Figure 9 TAKE-UP SIDE ASSEMBLY .....	15
Figure 10 TAKE-UP SIDE ASSEMBLY BOM.....	16
Figure 11 DRIVE SIDE ASSEMBLY .....	17
Figure 12 DRIVE SIDE ASSEMBLY BOM.....	19
Figure 13 TRANSMISSION OVERVIEW .....	19
Figure 14 BLADE GUIDE ASSEMBLY, FRONT (BM-V-S & SB).....	20
Figure 15 BLADE GUIDE ASSEMBLY, FRONT (BM-V-SDB & SD) .....	21
Figure 16 BLADE GUIDE ASSEMBLY, DRIVE SIDE (BM-V-S, SB, SD, SDB) .....	22
Figure 17 SPRAY TUBE UNDER BEAM ASSEMBLY .....	23
Figure 18 1710897: EXTERNAL SPRAY NOZZLE.....	23
Figure 19 TOP HANDLE ASSEMBLY .....	24
Figure 20 REAR HANDLE ASSEMBLY .....	25
Figure 21 MOTOR COVER ASSEMBLY .....	25
Figure 22 2HP MOTOR OPTIONS.....	26
Figure 23 3HP MOTOR OPTIONS.....	27
Figure 24 5HP MOTOR OPTIONS.....	28
Figure 25 POWER SUPPLY, 42V, with ANTI-TIEDOWN .....	29
Figure 26 POWER SUPPLY, 42V, without ANTI-TIEDOWN .....	30
Figure 27 POWER SUPPLY, NON 42V, with ANTI-TIEDOWN.....	31
Figure 28 POWER SUPPLY, NON 42V, without ANTI-TIEDOWN .....	31
Figure 29 POWER SUPPLY, SINGLE PHASE, 115 / 230V.....	32
Figure 30 WIRING DIAGRAM – SINGLE PHASE – 230V.....	33
Figure 31 WIRING DIAGRAM – SINGLE PHASE – 115V.....	34
Figure 32 WIRING DIAGRAM – 3 PHASE – DIFFERENT CONTROL AND MOTOR VOLTAGE –without Anti-Tie Down .....	35
Figure 33 WIRING DIAGRAM – 3 PHASE – SAME CONTROL AND MOTOR VOLTAGE –without Anti-Tie Down.....	36
Figure 34 WIRING DIAGRAM – 3 PHASE – DIFFERENT CONTROL AND MOTOR VOLTAGE –with Anti-Tie Down.....	37
Figure 35 WIRING DIAGRAM – 3 PHASE – SAME CONTROL/TRIGGER AND MOTOR VOLTAGE with Anti-Tie Down.....	38
Figure 36 WIRING DIAGRAM – 3 PHASE – 42V Motor option - with Anti-Tie Down .....	39
Figure 37 ELECTRIC MOTOR LEAD HOOKUP DIAGRAM 3 PHASE MOTOR.....	40

**Kentmaster Meat equipment (Beijing) Co.,Ltd**

(北京) 有限公司

Room 403, Fourth floor, Building 1, No. 21, Linhe Street, Linhe Industrial Development Zone, Shunyi District, Beijing

北京市 区林河工 开区林河大街 21 号 1 幢 4 403 室

MP: +86 18888823139. Telephone: 010 89496968

**Kentmaster Equipment & Material Bengbu Co. Ltd**

斯特 材料蚌埠有限公司

1st Floor, Building 29, Industrial Park for Small and Medium Enterprises, No. 635, Donghai Avenue, Longzihu District, Bengbu City

安徽省蚌埠市 子湖区 海大道635号工投中小企 园29幢一楼

微信公众号： 斯特公司

http: www.kentmaster-china.com

Email: nereus.mei@kentmaster.com