

9KG STACK DRYER/DRYER



MLE27 AND MLG27



LARGE CAPACITY

- Two large 9kg capacity dryers allows for large loads to be dried effectively
- Stack configuration allows for two dryers in the floor space of just one to get the most out of your laundry



CONTROLS TO MEET YOUR NEEDS

- Simple one touch cycle selection for easy of operation
- "PD" Coin or Card activated machines come stand with M-Series technology to allows owners to optimize earnings with multiple pricing options



FRONT-ACCESS PANEL

- Streamlines self-service by providing fast entry to internal component
- Minimizes downtime to help keep the machine running



BUILT TO LAST

- Four-roller suspension with permanently lubricating bearings
- Heavy-duty steel cabinet
- Blower guard — reduces service calls, helping to keep machines running at optimal turns

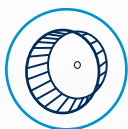

TURBOVENT® SYSTEM

- A high-speed blower wheel optimizes performance in long vents
- High airflow helps reduce drying times for a wide variety of loads
- Helps to increase efficiency and number of cycles over the life of the machine



COIN DROP OR CARD READER READY

MLE27PD (pictured)
Also available in gas



NON-COIN

MLE27PN (pictured)
Also available in gas

Single-Load Stack Dryer/Dryer		
Payment Configuration	Electric	Gas
Non-Coin	MLE27PN	MLG27PN
Coin Drop or Card Reader Ready	MLE27PD	MLG27PD



See maytagcommerciallaundry.com for warranty details.

9KG STACK DRYER/DRYER



MLE27 AND MLG27

SIDE VIEW

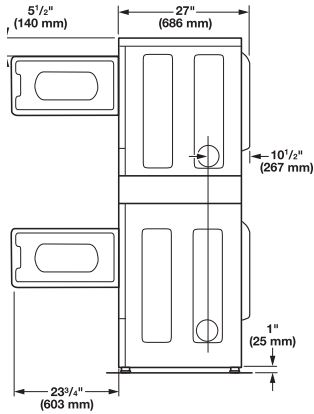

BACK VIEW

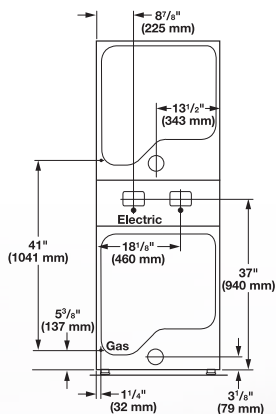

Maximum Exhaust Duct Length Per Number of Turns

Rigid Metal Vent

Box Hood and Louvered Style

Angled Hood Style

No. of 90° Turns



No. of 90° Turns	Box Hood and Louvered Style	Angled Hood Style
0	39.6 m	39.3 m
1	38.1 m	36.3 m
2	35.1 m	33.2 m
3	32.3 m	30.5 m
4	29.9 m	28.0 m

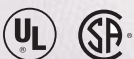

*Use 4" (100 mm) diameter rigid aluminum or galvanized steel duct. Never use plastic, non-metal or combustible duct. See specific instructions for proper installation. Because of continuous product improvement, Maytag reserves the right to change specifications without notice.

MODELS	MLE27PD MLE27PN	MLG27PD MLG27PN
COIN DROP / CARD READY NON-COIN		
Fuel Type	Electric	Gas
CAPACITY		
Cylinder Volume — liters	209.5	209.5
Cylinder Diameter — mm	667	667
Cylinder Depth — mm	590	590
DIMENSIONS		
Width — mm	686	686
Depth — mm	737	737
Height — mm	1,950	1,950
Door Opening — mm	514	514
Exhaust Duct Diameter — in. (mm)	4 (100)*	4 (100)*
CRATED DIMENSIONS		
Crated Width — mm	730	730
Crated Depth — mm	848	848
Crated Height — mm	2,008	2,008
APPROXIMATE WEIGHT		
Uncrated — kg	123.4	123.4
Crated — kg	133.4	133.4
ELECTRICAL REQUIREMENTS		
Voltage	220-240V - 50Hz	220-240V - 50Hz
Breaker/Fuse — amps	50	10
Airflow — CFM (CMM)	230 (6.5)	215 (6.1)
Electric Heating Element (watts)	4,600	N/A
Gas Rating — BTU/hr (kcal/hr)	N/A	24,000 (6,048)