

TOPLID

TopLid is the ultra compact tray-sealer by Gruppo Fabbri, known for its performance and simplicity of use.

Fully automatic, it is particularly suitable for the packaging of food products in a protective atmosphere, particularly meat, thanks to the patented gas exchange system.

The compact size, high productivity and simplicity of use make this machine unique. The design of the punching tool has resulted in the extreme lightness of the components, making the format change accessible to everyone.

Also available in a version completely made of steel, **TopLid** can be used both in supermarket departments and large and medium-sized packaging centres.

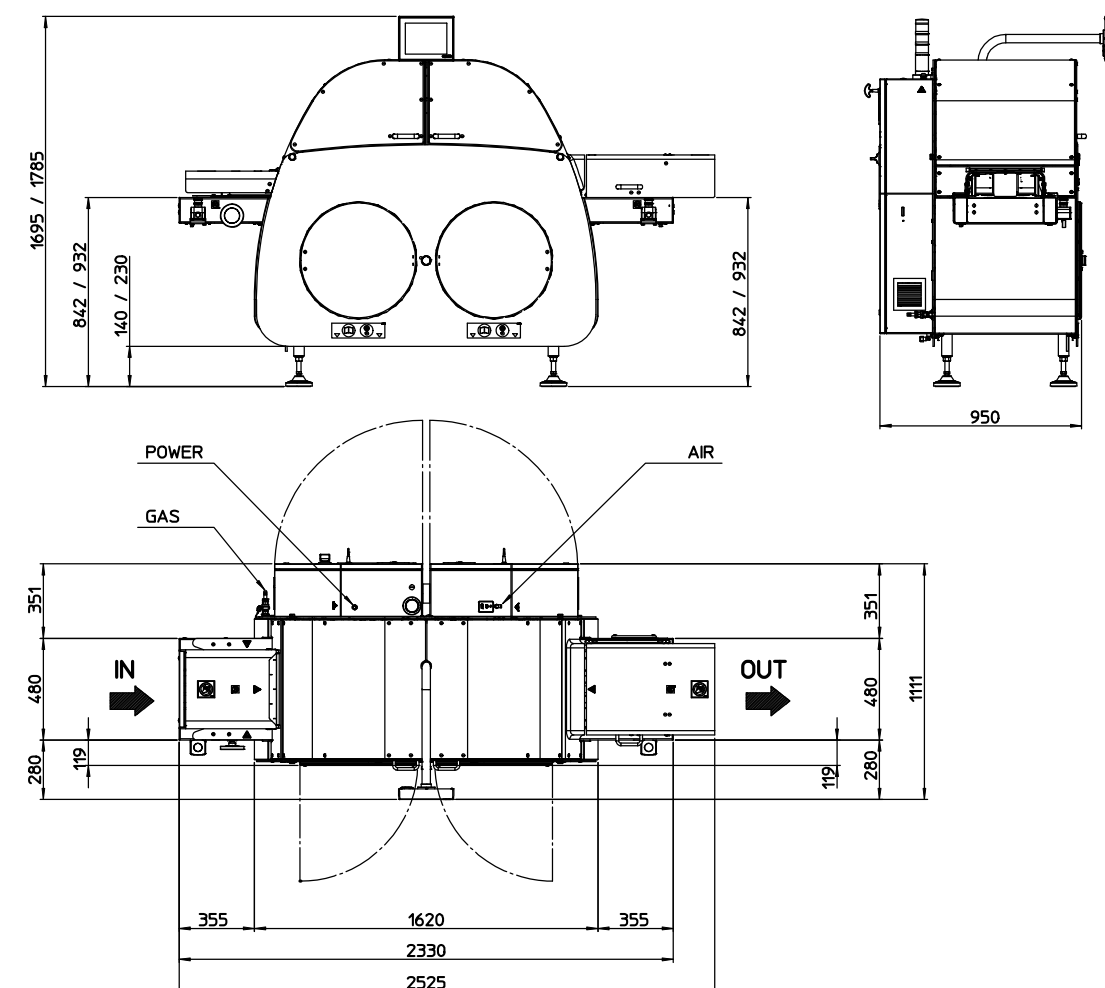

A Class of
its own

TOPLID
EN



Main characteristics	
Small space, great speed	TopLid occupies about 1.6m ² of floor area and provides packaging speeds up to 40 trays per minute in the double-line version. It is the only tray-sealer in the world to offer these benefits with such small dimensions.
Patented gas exchange system: perfect mixture, always	Thanks to the innovative gas exchange system, TopLid can handle mixtures with residual oxygen up to 0.3%, without resorting to expensive systems equipped with vacuum generating pump.
Sporty or classic clothing?	TopLid is available in both blue safety guard versions, to give you the opportunity to always have the right machine in the right place.
Format change: in less than 4 minutes and in complete safety!	The format change is managed by touch-screen monitors and operators can perform operations by following simple, step by step instructions. In addition, the positioning of the various parts is controlled by the machine at different times, effectively excluding the possibility of making errors. Great attention has been given to the operator at this delicate stage: the extremities of the staff are never in contact with the critical parts such as sealer tools and blades, so that each format change can take place in complete safety. Thanks to the tool lightness, the machine doesn't need a mould change chariot.
Ring road or highway: the choice is yours	TopLid can be ordered with a double line configuration, a solution that allows for the use of the full potential of the machine. This configuration can be easily converted to the single line version by simply changing the punching tool and the programme. In the same time that is needed to perform a format change, you will have a machine available that can package different types of trays at the most suitable speeds. Unique!
Touch-screen monitor: with the most beautiful colours	Simple and intuitive interface to control all machine functions with a simple touch. Everything, multi-lingual and coloured.
Guaranteed sealing	TopLid, in conjunction with the best performing film in the market, ensures excellent sealing even at maximum speed, ensuring higher safety standards to clients. TopLid provides the best performance with PELid 22, a 5-layer high barrier film, specially developed for tray sealer machines by Gruppo Fabbri.
Suitable for every tray, in every way	The automatic in-feed of TopLid allows for the packaging of trays without any need for prepositioning or spacing at the entrance, typical of traversing bar machines. It can also handle the same format with different heights at the same time, thanks to its innovative tray-loading system.
All accessible, all protected	TopLid, like all the packaging machines of Gruppo Fabbri, features several access points to various mechanical parts, thanks to the semi-covers that can be opened, the two front panels and the exit safety guards. This guarantees utmost simplicity and speed in performing operations of cleaning and regular maintenance. The cabinets containing the electric, electronic and pneumatic units have an IP65 degree of protection and are located at the rear of the machine, ensuring total protection.
Redundant product, overflowing solution	TopLid can package trays with overflowing products i.e. all those products that, due to presentation or management, need to rise above the ideal edge of the tray. Thanks to the dedicated optional feature, TopLid can offer a protected atmosphere solution with an attractive fresh appearance. It is special also in this regard.



Double row infeed option.



Very accessible inner parts.



Touchscreen monitor for machine interface.



Machine exit conveyor.



Tool workstation area.



Film unwind and tool workstation area.

1,6 Square meter surface area occupied.

4 Minutes to change format.

15 Up to 15 cycles/minute of maximum speed

170 Minimum reel width.

340 Maximum reel width.

365 Maximum tray size (L x W x H mm) 280 x 365 x 100.

OPTIONAL DEVICES
Motorized in-feed conveyors (1 m, 2 m, 4 m) 1 or 2 rows.
In-line exit roller and 90° (right/left) - 180° (right) motorized exit conveyors.
Photocell for product exit control.
Photocell for registered printed film.
Gas mixer and gas analyzer kit.
1, 2, 4 cavities moulds.
Protruding products.
Reversible 1-2 rows TopLid version.
Stainless steel covers.
Motorized tray-turning exit belt.
Server TCP/IP connection.
Teleservice and other optional features.

19 Optional features available from the list.

40 Up to 40 trays/minute in the 4-print set up.

110 Minimum tray format (L x W x H mm) 110 x 120 x 20.

620 Weight 620 kg.

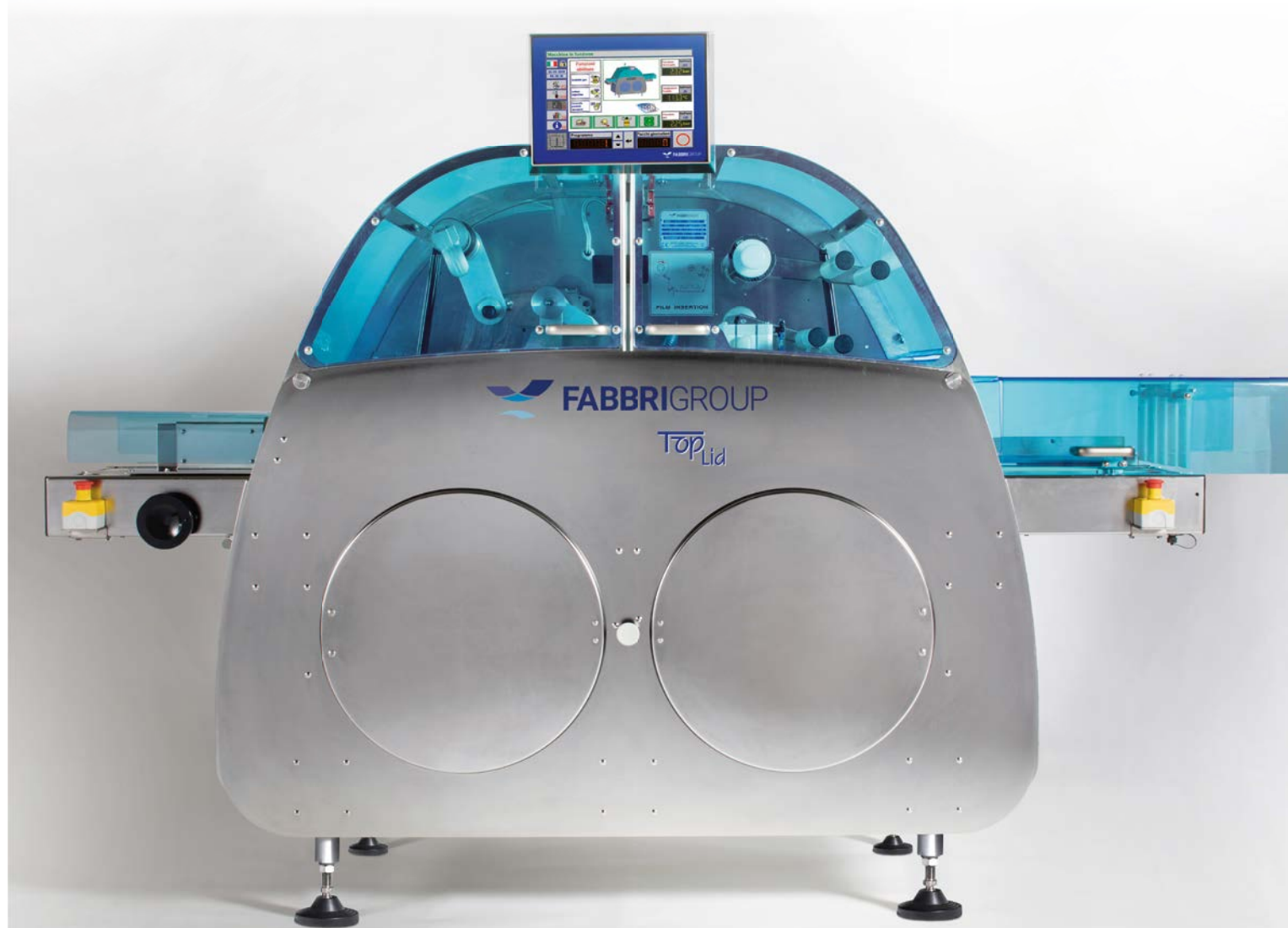

Gruppo Fabbri Vignola guarantees quick, efficient and widespread technical assistance, thanks to a team of qualified and multi-lingual professionals, always at the disposal of customers. **DISCLAIMER:** the content and information provided in this brochure are intended for general marketing purposes, therefore no subject (person or company) must consider them exact or complete. Gruppo Fabbri Vignola, its company organisations, managers, officials, employees, agents and consultants will not be held liable (including liability resulting from error or negligence, without any limitation) for any direct or indirect loss, damage, cost or obligation which could have been suffered resulting from the use or reliance on that contained or omitted in this brochure. Gruppo Fabbri Vignola reserves the right to modify the specifics of its products without any prior notice. For further technical or economical information, please contact the Gruppo Fabbri Vignola Sales Department.