

# CAIZER F60



High Quality, Affordable Price

**6000kg SWL**  
**Platform Length : 6,000mm**

The hydraulic cylinder is located inside the platform thus perfectly protected.

High-resistant, galvanised and pre-stretched metal cables.

Large-diameter pulleys with self-lubricating and maintenance-free bushes.

Adjustable parking ratchet rails ensure that the platforms and cross members are horizontal within 4-wheel alignment tolerances.

Automatic spring-loaded safety hook system in the event of cable breakage also ensures complete stability during parking.



**15,000 CYCLE TESTED**





# DRAWING: F60

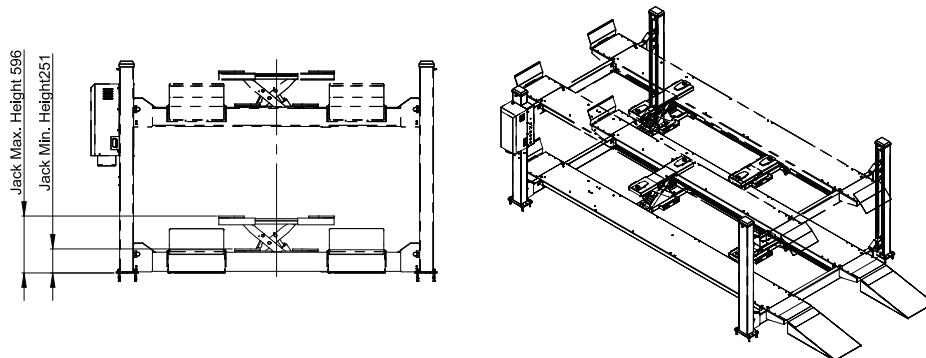
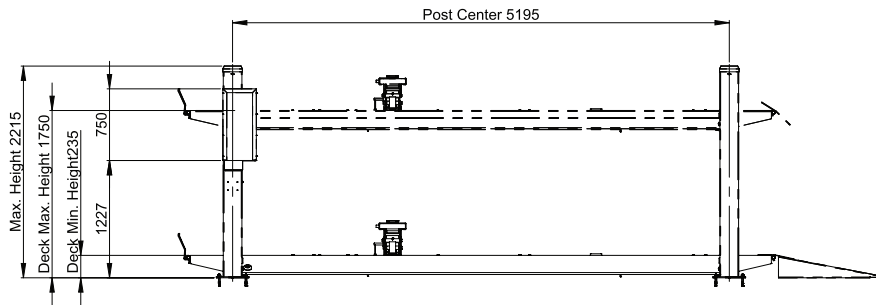
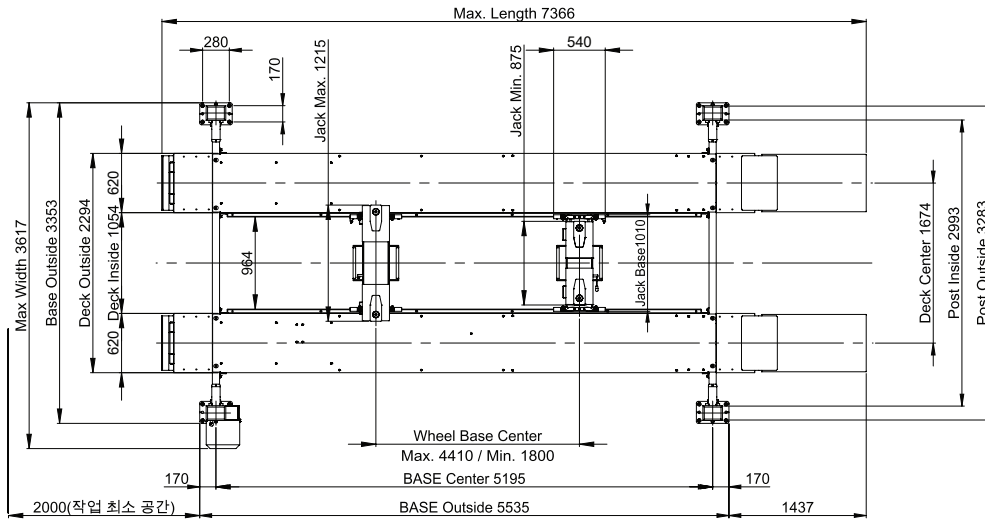

## CAIZER 4 POST HOISTS F60

Lifting Capacity : MAIN	6,000 Kg
JACK	3,000Kg
Max. Height : MAIN	1,750 mm
JACK	595 mm
Min.Height : MAIN	235 mm
JACK	251 mm
Stroke : MAIN	1,515 mm
JACK	344 mm
Overall DIM	Out-Width-In-Width x Length : 3,616 x 2,254 x 7,384 (mm) Max.Height : 2,215 (mm) Main Plate; Out-Width x In-Width x Length : 2,254 x 1,054 x 6,076 (mm)
Ascending Time : Main	Approx. 40 ~ 60 sec
Jack	5 ~ 15 sec
Descending Time : Main	Approx. 45 ~ 60 sec
Jack	5 ~ 15 sec
Elec & Motor	3PH : 3HP x 4P x 220V / 380V x 50/60Hz
Control	Control Panel (Push Button)
Net Weight	About 1,920 Kg
Jack (Option)	140Kg / 1EA
Total Weight	Approx. 2,200Kg



sales@caizer.com.au



(02) 4255 7888



CAIZER.COM.AU