

ToolReg®

PRESET REGULATOR FOR AIR WITH SECONDARY PRESSURE RELIEF



ToolReg®

ToolReg® in-line preset pressure regulator with automatic secondary pressure relief.

The ToolReg® regulator is an independent piston regulator that can be mounted on any pneumatic tool or installed in every compressed air system. It supplies a constant, exact outlet pressure regardless of the inlet pressure. The pressure is factory-set and cannot be changed. The ToolReg® prevents “dynamic pressure waste”, which arises when the pressure and flow at the withdrawal point are unnecessarily higher than those specified by the manufacturer to achieve the desired function. “Dynamic pressure waste” is extremely costly – a waste of energy that may be found throughout the industry.

For pneumatic tools, the ToolReg® must be mounted directly on the tool in order to ensure correct pressure and that possible pressure drops in hoses, tubes, etc., do not influence the pressure on the tool itself.

Preset regulators are an economical way to achieve the ideal pressure in the tool. Furthermore, the residual pressure in the tool is relieved when it is removed from the compressed air supply line, preventing unintentional actuation of the tool that could have disastrous consequences.

Your advantages

- ✓ Automatic secondary pressure relief
- ✓ Protection guaranteed – no residual pressure in the tool
- ✓ High flow performance (0 – 4.600 Ltrs./Min / 0 – 162 scfm)
- ✓ High pressure performance
- ✓ P1 – inlet pressure up to 25 bar / 355 psig)
- ✓ Corrosion resistant
- ✓ Supplies tools exclusively with the specified pressure
- ✓ No pressure gauge needed
- ✓ Prevents compressed air waste
- ✓ Saves energy – reduces costs
- ✓ Highly reliable
- ✓ Locked to prevent pressure change - tamperproof
- ✓ Lightweight - Small and compact size



Technical data

Max. inlet pressure:	25 bar
Outlet pressure (preset):	2... 8 bar
Flow:	500... 4600 NI/min
Connection:	1/4" ... 3/4" BSP/NPT
Temperature range:	0°C to 60°C
Weight:	40g... 258g

Applications

Pneumatic Impact Wrench	Lifting bags
Pipe plugs	Pneumatic doors
Pick and place units	Workshop air lines
Nail guns	Jackhammers
Pneumatic power tools	

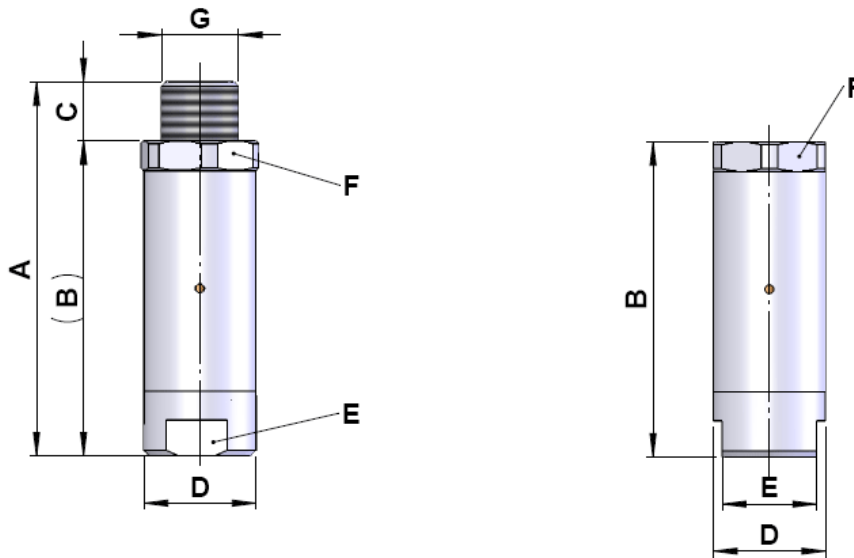

*Dimensions see datasheet on website – protect-air.com



TRI-MATIC AG
Bösch 82
CH-6331 Hünenberg
Phone +41 (0)41 780 22 22
Email: info@tri-matic.ch



Distributed by:
Compressed Air Australia Pty Ltd
GPO Box 2792, Darwin NT 0801
Phone: 1300 787 688 / +61 8 8983 3999
Email: info@caasafety.com.au
www.caasafety.com.au