TECHNICAL DATA SHEET

MH Range

Off-road IC forklifts

Region 2



2000 - 2500 kg

TECHNICAL SPECS

Stage 3A

Specifications	1.1	Manufacturer			MANITOU
	1.2	Model			MH 25
	1.3	Power source			Diesel
	1.4	Driving position			Seated
	1.5	Nominal capacity	Q	kg	2500
	1.6	Load - centre of gravity	c	mm	500
	1.8	Distance from the load-bearing surface to centre of front axle	x	mm	625
Weight	1.9	Wheelbase	y	mm	1800
	2.1	Operating weight		kg	4260
	2.2	Axle load, with load, front / rear		kg	5812 / 948
Tyres, frame	2.3	Axle load, without load, front / rear		kg	1750 / 2510
	3.1	Tyre equipment: cushion (V), superelastic (SE), pneumatic (L)			L
	3.2	Size of front wheels			280/80 R20 XMCL
	3.3	Size of rear wheels			27,10- 12 IC 30 14PR
	3.5	Number of front wheels (x = drive wheel) / rear wheels			2x / 2x
	3.6	Front wheel gauge (middle of wheels)	b10	mm	1160
	3.7	Rear wheel gauge (middle of wheels)	b11	mm	1164
Dimensions	4.1	Tilt of mast forwards / backwards (1)	α / β	deg	10 / 12
	4.2	Height mast lowered	h1	mm	1835
	4.3	Free lift	h2	mm	130
	4.4	Lift height	h3	mm	3300
	4.5	Height mast extended	h4	mm	4070
	4.7	Height of overhead guard (cabin)	h6	mm	2105
	4.8	Height of seat	h7	mm	1025
	4.12	Height of towing bar	h10	mm	310
	4.19	Overall length	l1	mm	4045
	4.20	Length at fork heels	l2	mm	2945
	4.21	Total width (overall)	b1	mm	1450
	4.22	Fork dimensions	s / e / l	mm	40 / 100 / 1100
	4.23	Fork carriage to DIN 15173 A/B			FEM2A
	4.24	Width of fork carriage	b3	mm	1260
	4.31	Ground clearance below mast	m1	mm	266
	4.32	Ground clearance at centre of wheel-base	m2	mm	260
	Performances	4.33	Width of aisle for pallet 1000 x 1200 crossways	Ast	mm
4.34		Width of aisle for pallet 800 x 1200 lengthways	Ast	mm	5290
4.35		Turning radius	Wa	mm	3265
4.36		Inner turning radius	b13	mm	1080
5.1		Speed of travel laden / unladen		km/h	14
5.2		Speed of raise laden / unladen		m/s	0,4 / 0,5
Motors	5.3	Speed of lowering laden / unladen		m/s	0,5 / 0,4
	5.5	Nominal towing power laden / unladen		daN	3550
	5.7	Gradeability with / without load		%	50 / 48
	5.10	Service brake			Hydraulic
Miscellan.	7.1	Manufacturer / Type of engine			Kubota V2403 M-E3B
	7.2	Power delivery		kW	36
	7.3	Regime nominal		tr/min	2700
	7.4	Number of pistons / Cubic capacity		cm ³	4/2434
Miscellan.	8.1	Power control			Hydraulic
	8.2	Operating pressure for attachments		bar	170
	8.3	Oil flow for attachments		l/min	77
	8.4	Average noise level for the driver (in motion) measured / guaranteed		db (A)	104

1- Values with duplex mast

Data is based on standard configurations (forks, mast).
Performance data and dimensions are nominal and subject to tolerances.
Manitou products and their specifications are subject to change without notice.

DIMENSIONAL DRAWINGS

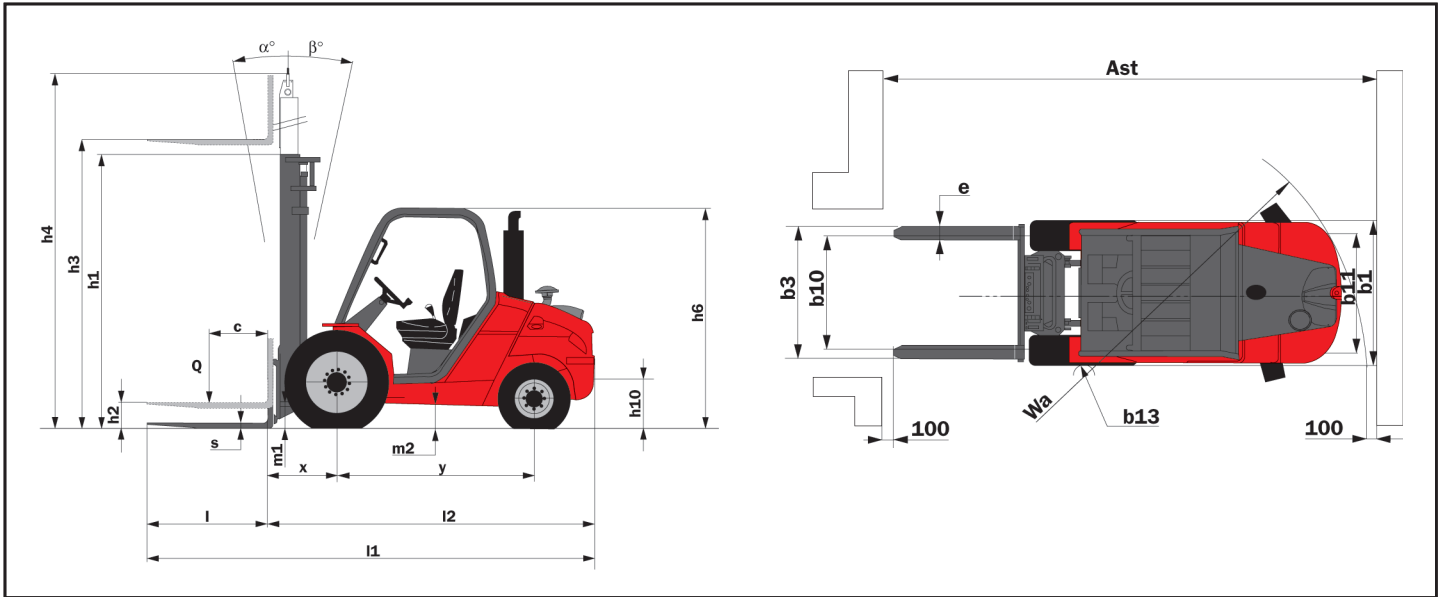

MASTS AND RESIDUAL CAPACITIES

MH 25			Total Visibility Duplex									
			DVT27	DVT30	DVT33	DVT35	DVT37	DVT40	DVT45	DVT50	DVT55	DVT60
h3	Lift height	mm	2700	3000	3300	3500	3700	4000	4500	5000	5500	6000
h1	Height mast lowered	mm	1995	2145	2295	2395	2555	2745	2995	3245	3495	3785
h2	Free lift	mm	130	130	130	130	130	130	130	130	130	130
h4	Height mast extended*	mm	3531	3831	4070	4331	4531	4831	5331	5831	6331	6831
	Residual capacity at max height MH20 - c=500mm	kg	2500	2500	2500	1900	1900	1550	1100	-	-	-
	Tilt of mast forwards / backwards	deg	10 / 12	10 / 12	10 / 12	10 / 12	10 / 12	10 / 12	10 / 12	6 / 6	6 / 6	6 / 6

MH 25			Free Lift Triplex								
			TLL37	TLL40	TLL43	TLL47	TLL50	TLL55	TLL60	TLL65	TLL70
h3	Lift height	mm	3700	4000	4300	4700	5000	5500	6000	6500	7000
h1	Height mast lowered	mm	1945	2045	2145	2295	2395	2555	2745	2995	3245
h2	Free lift	mm	1221	1321	1421	1571	1671	1831	2021	2271	2521
h4	Height mast extended*	mm	4469	4769	5069	5469	5769	6269	6769	7269	7769
	Residual capacity at max height MH20 - c=500mm	kg	1900	1550	1250	1000	-	700	-	-	-
	Tilt of mast forwards / backwards	deg	10 / 12	10 / 12	10 / 12	10 / 12	6 / 6	6 / 6	6 / 6	6 / 6	6 / 6

* Without backrest and Integrated sideshift

Your nearest MANITOU dealer :



Head office

B.P. 249 - 430 rue de l'Aubinière - 44158 Ancenis Cedex - France

Tel: 00 33 (0)2 40 09 10 11 - Fax: 00 33 (0)2 40 09 10 97

www.manitou.com



This brochure describes versions and configuration options for Manitou products which may be fitted with different equipment. The equipment described in this brochure may be standard, optional or not available depending on version. Manitou reserves the right to change the specifications shown and described at any time and without prior warning. The manufacturer is not liable for the specifications given. For more information, contact your Manitou dealer. Non-contractual document. Product descriptions may differ from actual products. List of specifications is not comprehensive. The logos and visual identity of the company are the property of Manitou and may not be used without authorisation. All rights reserved. The photos and diagrams contained in this brochure are provided for information only.
MANITOU BF SA - Limited company with board of directors - Share capital: 39,547,824 euros - 857 802 508 RCS Nantes