

Freestanding Electric Fryers

The Austheat 3 phase electric fryers are ideal for take away shops or where high-speed production of fried food, such as fish and chips, is required.



AF812 pictured



AF822 pictured



AF813 pictured

AF812 Single Pan 29 Litres 15 kW

The Austheat AF812 has a single pan and comes complete with two heavy-duty, stainless steel baskets. With robust stainless steel construction and a tank thickness of 1.5 mm, the AF812 will give you years of trouble free service in the production of quality fried foods.

AF812R (Rapid Recovery) 18 kW

Featuring 18 kW of power the AF812R is designed to perform where the demand for quick recovery is extreme.

AF822 Twin Pan 2 x 14 litres 15 kW

This compact high performance fryer has two separate tanks with individual controls. These provide the ability to operate the tanks at different temperatures, to separate flavours or to shut down one tank in quieter periods. The AF822 comes complete with two heavy-duty, stainless steel baskets and has all the features of the other fryers in the range.

AF813 Single Pan 39 Litres 18 kW

This high performance single pan fryer has been specifically designed for the production of high volumes of fish and chips. It is equipped with three heavy-duty, stainless steel baskets but can be used stand-alone for wet batters. Construction is similar to that of the AF812.

AF813R (Rapid Recovery) 22.5 kW

With 22.5 kW of power the AF813R is designed to perform in the most demanding environment.

Freestanding Electric Fryers

SPECIFICATIONS

MODEL	BASKETS No.	POWER	CURRENT Amps	PHASE	OIL CAPACITY	COOKING TIME* (per 1.5 kg)	HOURLY OUTPUT PER HOUR* (frozen), (thawed)	HEAT UP TIME (to 185° C)
SINGLE TANK								
AF812	2	15 kW	63	3 (+N)	29 litres	2-3 mins	32 kg, 39 kg	10 mins
AF812R	2	18 kW	72	3 (+N)	29 litres	2-3 mins	35 kg, 42 kg	9 mins
AF813	3	18 kW	72	3 (+N)	39 litres	2-3 mins	40 kg, 49 kg	10 mins
AF813R	3	22.5 kW	93	3 (+N)	39 litres	2-3 mins	45 kg, 55 kg	8.5 mins
DOUBLE TANK								
AF822	2	15 kW	61	3 (+N)	2 x 14 litres	2-3 mins	32 kg, 39 kg	10 mins

* Approximate productivity 12 mm sq blanched chips.

Electric vs Gas

The benefits of electric fryers are significant - from contributing to a cleaner work place, to providing financial savings. Maintaining a cooler, more pleasant work environment is possible as electric fryers generally add less heat to your kitchen than gas fryers. Additionally, as there is no gas flame, Austheat fryers deliver a cleaner, healthier working environment by not burning the available oxygen, or emitting burnt and unburned gases into your kitchen.

Longevity

Electric emersion elements tend to greatly outlast gas burners and their replacement costs are considerably less. Additionally, tank deterioration that is so prevalent in gas fryers is negligible in electric fryers.

Energy efficient

In electric fryers, the majority of the energy from electricity is supplied directly into the elements, which are immersed in the oil, providing a very energy efficient solution and quick recovery time when loading food into the fryer. In the case of gas fryers, much of the energy is ultimately lost in the flue.

High performance

Designed to achieve a balance of high output and fast recovery, Austheat electric fryers consistently deliver fried food of the highest quality, while maximizing the life of your oil.

Easy to clean

Austheat fryers feature elements that swing out and up in seconds, providing access to a smooth, open, square tank for easy cleaning. There are no gas pipes to clean around and under, nor awkward crevices to access to thoroughly clean as can be the case with gas fryers.



Freestanding Electric Fryers

Dual control thermostats for efficiency and peace of mind

Each tank has a cook/idle switch that allows you to quickly switch between two temperature settings. Each cook/idle switch is linked to two thermostats housed behind the bottom door – one thermostat can be programmed with a cook temperature and the other with an idle temperature setting, reducing operating costs. The dual thermostats provide peace of mind that in the unlikely event of a thermostat failure, where the secondary thermostat can be set to cook temperature to allow you to continue operating.

Rear castors and adjustable front legs for complete manoeuvrability



Fishplate, element cover and cool zone below elements to prolong your oil life



Open tank provides clear access for easy cleaning

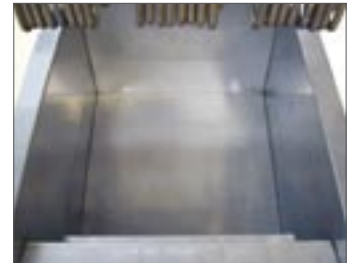

Safety thermostats

All units are fitted as standard with manual reset over-temperature safety cut-outs.

Cool zone

All Austheat fryers provide a cool zone that collects crumbs. The cool zone prevents the burning of crumbs so that the oil is not tainted by a burnt flavour. It also prolongs the life of the oil.



Fryers can be joined together modularly using the tank joining cover (SS1794)



Freestanding Electric Fryers

Melt cycles on all thermostats for use with solid cooking oil



Melt cycles on all thermostats for use with solid cooking oil



Easy to read LED digital display



Cook idle switch for quick control



Dual control thermostats for peace of mind



Wide 25 mm (1") diameter drain pipe with lockable ball valve.



Tilt up elements for safe and easy cleaning of tank

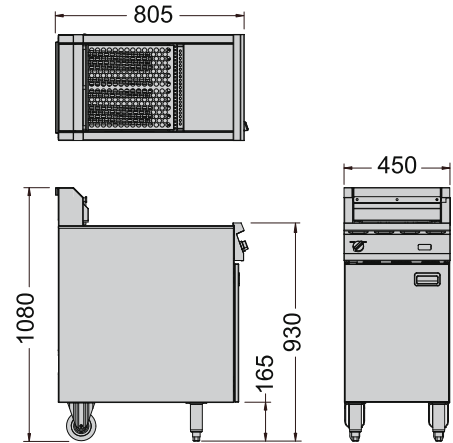

AF812 & AF812R dimensions (mm)

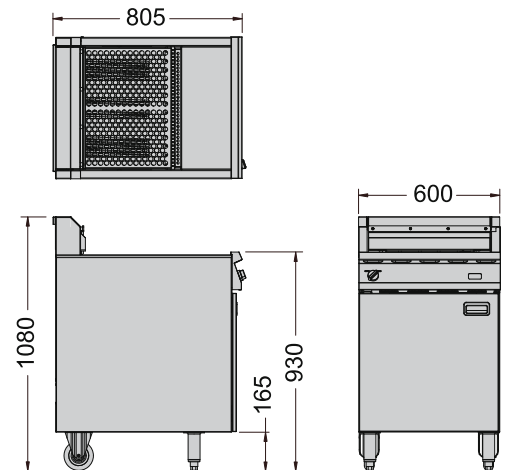

AF813 & AF813R dimensions (mm)

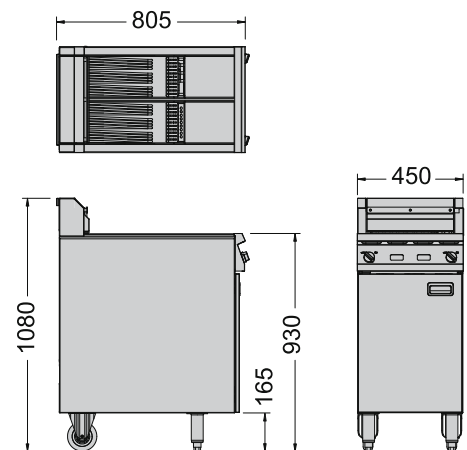

AF822 dimensions (mm)