

MODEL RANGE

FH 84TF 3A

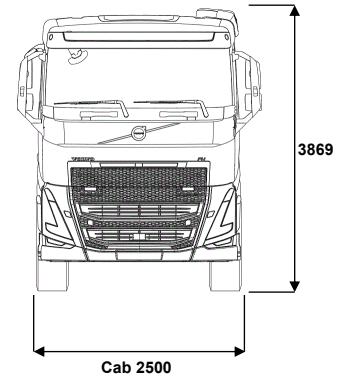
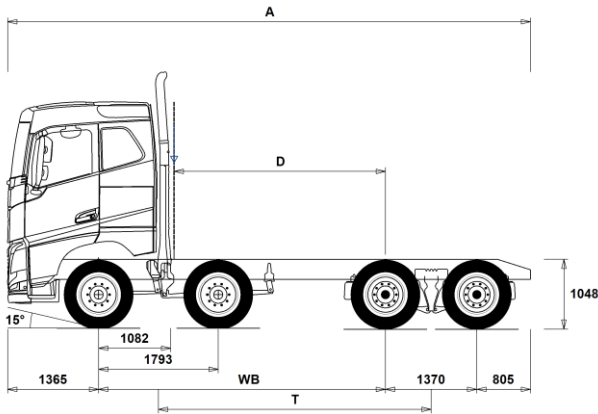

Chassis Dimensions [mm]

WB Wheelbase	4300
A Overall Chassis Length	7840
D Center of rear axle to back of cab	3168
T Theoretical Wheelbase	4088

Chassis Weights [kg]

Front Axles	7595
Rear Bogie	3195
Kerb Weight	10790

Turning Diameter [mm]

Turning Circle Diameter Kerb to Kerb	18100
Turning Circle Diameter Wall to Wall	19400

Plated Weights [kg]

	Plated	Design
Gross Vehicle Weight	27500	34000
Gross Combination Weight	42500	70000
Front Axles	11000	13000
Rear Bogie	16500	21000

Important Notes

Chassis Dimensions

Cab Height: +84 mm for CAB-XHSL.
 D-measure includes a front clearance of 50 mm and for rigid trucks also a subframe of 100 mm.
 Height can vary ± 20 mm for leaf and ± 10 mm for air suspension.
 All dimensions are for unladen chassis and any tag axles down.

Weight and dimensions are based upon the following tyres:
 Front Axle Tyres: 295/80R22.5
 Drive Axle Tyres: 295/80R22.5

Chassis weight includes oil, water, AdBlue, 0 litres fuel and without driver. Kerb weight can vary $\pm 3\%$.

Turning diameters are theoretically calculated.

Legal weights can differ from country to country.

For more detailed weight information, including optional equipment weights, ask your Volvo sales contact to enter your specification into the Volvo Weight Information system (WIS).

Do NOT use this drawing for bodybuilding. Refer to Volvo Bodybuilder Instructions and chassis assembly drawing FH84TF3A.

MODEL RANGE

FH 84TF 3A

Important Notes

Chassis Dimensions

Cab Height: +84 mm for CAB-XHSL.

D-measure includes a front clearance of 50 mm and for rigid trucks also a subframe of 100 mm.

Height can vary ± 20 mm for leaf and ± 10 mm for air suspension.

All dimensions are for unladen chassis and any tag axles down.

Weight and dimensions are based upon the following tyres:

Front Axle Tyres: 295/80R22.5

Drive Axle Tyres: 295/80R22.5

Chassis weight includes oil, water, AdBlue, 0 litres fuel and without driver. Kerb weight can vary $\pm 3\%$.

Turning diameters are theoretically calculated.

Legal weights can differ from country to country.

For more detailed weight information, including optional equipment weights, ask your Volvo sales contact to enter your specification into the Volvo Weight Information system (WIS).

Do NOT use this drawing for bodybuilding. Refer to Volvo Bodybuilder Instructions and chassis assembly drawing FH84TF3A.