

XE10S MINI EXCAVATOR

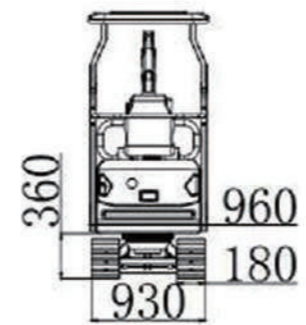

- ☆ Engine: Koop diesel hydraulic oil cooling
- ☆ Easy access to engine gas strut hood
- ☆ Foldable canopy design for low access
- ☆ Large ranges of attachments available

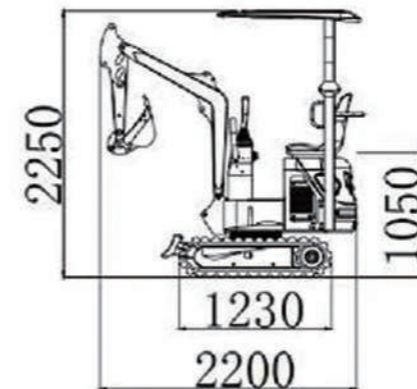
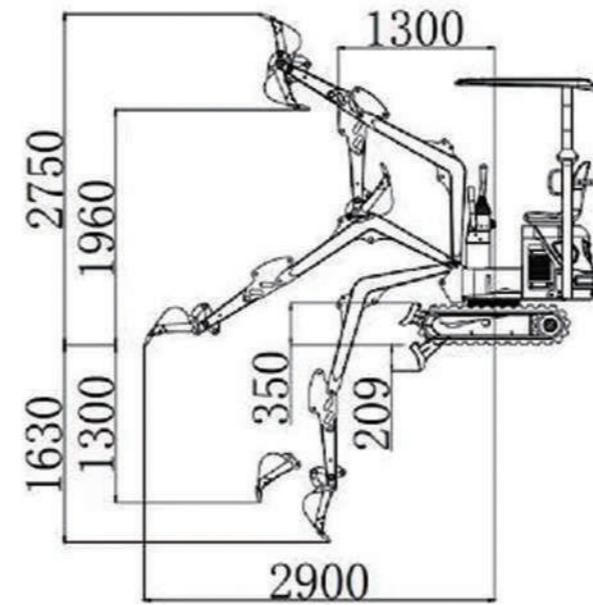

Model/Specifications	XE10S	XE13SE
Operation Weight(kg)	1000	1200
Bucket capacity(m ³)	0.028	0.028
Engine model	KOOP	KOOP
Engine power(Kw/Hp)	8.6/11.7	8.6/11.7
System pressure(Mpa)	16	16
Swing speed(rmp)	12	11
Maximum climbing angle	30°	35°
Walking speed	2km/h	2km/h
Hydraulic oil tank volume	18L	18L
Fuel tank volume	10L	10L

Dimensions		
Dimensions	2770X870X2150	2770X870X2150
Swing Boom/Arm	/	Yes
Total track length	1230mm	1230mm
Expandable Track	/	Yes
Track Adjustable Width	860	800-950
Width of track	180mm	180mm
Track material	Rubber track	Rubber track

Working Range		
Max. digging radius	2900mm	2900mm
Max. digging depth	1650mm	1650mm
Max. digging height	2750mm	2750mm
Max. dumping height	1960mm	1960mm
Max. digging distance	2900mm	2900mm
Min. gyration radius	1300mm	1300mm
Max. lifting height of bulldozer	180 mm	180 mm
Blade maximum digging depth	210 mm	210 mm
Width of chassis	930mm	930mm
Platform ground clearance	375mm	375mm

MXG Machinery assume no responsibility or liability for any errors or omissions in the content of this brochure. Specifications from the manufacturer are subject to change without notice. Refer to our sales team for model details at time of purchase.

0401 347 788
1800 834 611
Info@mxg.com.au

www.mxg.com.au
Melbourne Branch: 10-14 Citrus St, Braeside VIC 3195