

STATUS PROVAC 360

PROFESSIONAL VACUUM PACKING MACHINE

USER MANUAL



STATUS
innovations

1. SAFETY INSTRUCTIONS AND INTRODUCTION

1.1. OPERATING CONDITIONS

Maximum ambient temperature in normal use is +40°C; the average of temperatures over a 24-hour period should not exceed +35°C. Minimum ambient temperature allowed is -5°C. Surrounding air should be clean; relative humidity should not exceed 50 % at the maximum temperature

of +40°C. Higher relative humidity is allowed at lower ambient temperature (e.g. 90 % at +20°C).

If the machine is not operational for 5 minutes, it goes into standby mode and the mode of operation has to be chosen again – Auto or Manual.

1.2. IMPORTANT SAFETY INSTRUCTIONS

- a.) Working surface must be dry, normal temperature (not hot) and clear from obstructions.
- b.) Before connecting the appliance to mains socket, check the power cord, plugs and socket. If you observe any defect, contact our repair service listed below.
- c.) Machine should be cleaned only with a dry or slightly damp cloth.
- d.) Never touch the Sealing Strip when using the machine (Item 17 in Figure 1) – it may be hot.
- e.) Use the machine only for the purposes described in the User Manual.
- f.) If the supply cord is damaged, it must be replaced by the manufacturer, its service agent or similarly qualified persons in order to avoid a hazard.
- g.) This machine can be used by children aged from 8 years and above and persons with reduced physical, sensory or mental capabilities or lack of experience and knowledge only if they have been given supervision or instruction concerning use of the machine in a safe way and understand the hazards involved.
- h.) Children shall not play with the machine. Cleaning and user maintenance shall not be made by children without supervision.
- i.) Warranty is invalid if:
 - The machine has been tampered with.
 - The machine has been used for unintended purposes.
 - Safety regulations and instructions in the User Manual were not respected and followed.

The manufacturer will not accept responsibility for any damage that may occur as a result of not following the User Manual or improper use.

1.3. MAINTENANCE AND CLEANING

- a.) Unplug the machine.
- b.) Use a soft, damp cloth to clean the machine. Do not use anything which could scratch or damage the surface. Never submerge the machine in water or place it under running water. Never squirt detergent directly onto or into the machine.
- c.) Before using the machine make sure that it is completely dry.
- d.) The Sealing Strip is covered with Teflon. Remove any plastic residues using a soft cloth.
- e.) You can only clean the Sealing Strip when the machine has cooled down. Never try to clean the sealing strip using a sharp object.
- f.) If the black foam seals become contaminated with grease or liquid, then you can wash them in soapy water, rinse and dry them before replacing them. This will increase the lifespan of the foam seals.

1.4. GENERAL INFORMATION

Status Provac 360 is the first machine for professional use from Status Innovations. It is intended for long-term storage of foodstuffs in vacuum and for vacuum packing of foods in bags or vacuum containers. It was developed especially for professional kitchens, butcheries, cheeseeries, and other production facilities, which store large quantities of foods daily. It can also be used by those who want only the best and have large quantities of foods they want stored quickly and efficiently.

This machine represents the new generation of Status vacuum packing machines, designed to be even more user-friendly. It is developed and produced by Status d.o.o. Metlika, Slovenia.

It features unprecedented NEW FUNCTIONS:

- **Status Smart Seal: A sealing process, which ensures remarkably fast vacuum packing cycles and what is more it is energy efficient.**
 - The machine automatically adjusts sealing time according to the temperature of the sealing mechanism (the longer the machine is active, the less time is needed to complete the sealing process).
 - During the sealing process the machine is completely silent and energy-efficient. Since it has two sealing bars Provac 360 does not need to be preheated before operation. The double seal acts as an additional safeguard when vacuum packing moist and delicate foodstuffs in case liquid would seep through the first seal.
- **Status Smart Open/Lock:**
 - The lid of the machine opens automatically in the Auto mode.
 - Exceptionally easy locking/unlocking due to the readily accessible handle on the lid.
 - A pivoted locking system enables the lock to be operated quick and easy and does not require great force. The construction is designed to lock securely and without undue wear to the materials, which ensures the longevity of the product.
- **Status Stiki:** A reusable and easily detachable double-sided adhesive tape for the easiest vacuum packing in the world. Attach the adhesive tape to the designated position, remove the top protective layer and simply tape the bag to the Stiki adhesive

tape before vacuum packing. The bag is perfectly straight and without creases, while the accuracy of bag placement on the sealing strip ensures the most economical use of the bag. The machine comes with five Status Stiki adhesive tapes, which allow for up to 1000 vacuum packing cycles.

Most significant advantages of vacuum storage:

- Preserves vitamins, minerals, nutrients, and the aroma of foodstuffs.
- Protects foodstuffs from the spread of mould and bacteria.
- Prolongs the shelf life of foodstuffs.
- Prevents the unpleasant mixing of odours in a refrigerator and freezer.

You can also prolong the freshness and shelf life of foodstuffs by using Status vacuum containers, lids, a canning jar sealer and a jug, which can all be vacuum sealed with a manual or an electric vacuum pump. All these products can also be vacuum sealed with Provac 360 which comes equipped with a special tube for this type of vacuum packing.

We also have to mention that Status' Provac 360 helps you save money, since you can buy in bulk, repack your purchase in portions and then vacuum package. Food can be divided into smaller serving portions, vacuum packaged and stored in the refrigerator for a longer period of time.

The serial number is located on the technical label of each individual machine.

Before first use please read the user manual thoroughly and follow the instructions.

Contact us if you have additional questions, opinions or comments.

For more explicit directions visit our website <http://innovations.status.si/shop/vacuum-packing-machines>. Use the same address to locate an online version of this user manual.

The use of the machine is simple and efficient. You will store food in an entirely natural and healthy way, the food will remain fresh longer, and you will save time and money.

1.5. COMPONENTS AND FUNCTION BUTTONS

Figure 1 below shows components of the vacuum packing machine. Numbers in explanations of machine operation are used in the same manner as in the Figure throughout the user manual.

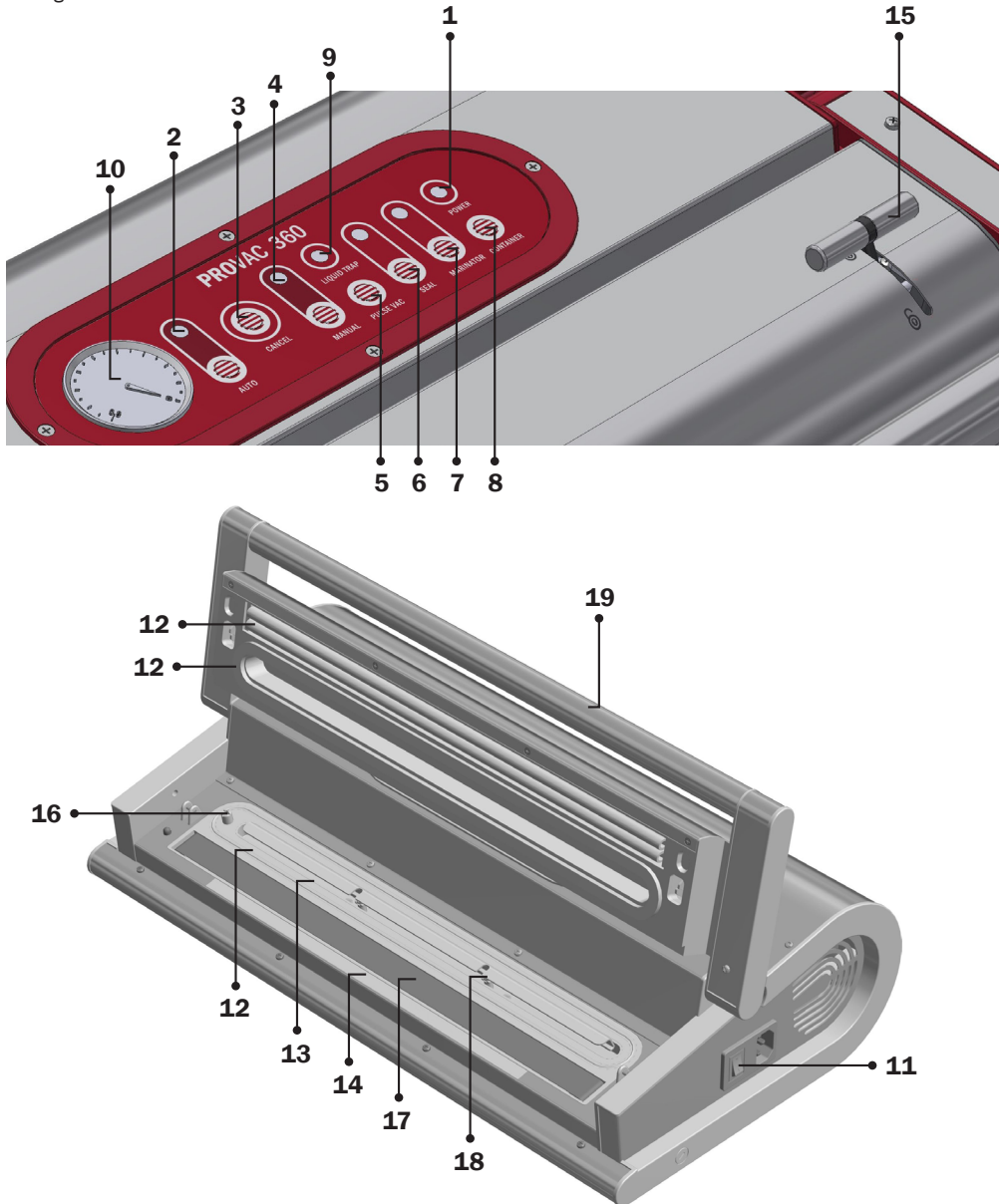

Figure 1: STATUS PROVAC 360 – components are marked with numbers.

LABEL	
1.	Power (On/Off) An On/Off indicator. When the machine is on and in standby mode the light is green.
2.	Auto (automatic vacuum packing process) Press Auto button, adjust the foodstuff in the bag, lower the lid and press it down for a few seconds. The machine operates the task automatically. After the process is complete the lid opens.
3.	Cancel The machine cancels an operation and reverts to the beginning of a selected programme.
4.	Manual Used in the following two situations: <ul style="list-style-type: none"> • In the process of vacuum packing delicate, soft and moist foodstuffs (followed by the use of Pulse Vac and Seal buttons). • In the process of turning foil rolls into bags.
5.	Pulse Vac (pulse vacuum) Used in the manual operating mode or with manual vacuum packing. When you hold Pulse Vac down the machine is creating vacuum (vacuum pump is running), when you release the button the operation stops. The process can be repeated until the desired amount of air has been removed.
6.	Seal Used in two situations (both in the manual operating mode): <ul style="list-style-type: none"> • In the process of turning foil rolls into bags. • With manual vacuum packing.
7.	Marinator (marinating) Begins the marinating programme in a vacuum container. This a fully automated process that lasts for 18 minutes. The light switches off indicating that the process has ended. A vacuum container and a marinating attachment are accessories that are sold separately.
8.	Container For the vacuum sealing of Status vacuum products (containers, lids, jug, and stopper) by using an attachment and a tube. The vacuum sealing process stops automatically when pre-adjusted pressure is reached.
9.	Liquid trap The light turns on to indicate that during the vacuum packing process the machine drew liquid from the foods out of the vacuum bag and into the vacuum channel.
10.	Manometer Displays the established level of vacuum.
COMPONENTS	
11.	On/Off Switch The machine is switched on by moving the button to position I.
12.	Gaskets Gaskets for vacuum packing and gaskets for sealing.
13.	Vacuum Channel If the liquid from a foodstuff enters the machine, the machine stops operating and the Liquid Trap light turns on. After cleaning the vacuum channel you can continue vacuum packing.
14.	Status Stiki™ A reusable and easily detachable double-sided adhesive tape for the easiest vacuum packing in the world. Stiki's main purpose is facilitating the vacuum packing process and ensuring the most economical use of the bag. The set includes 5 double-sided Status Stiki adhesive tapes.

15.	Lock/Unlock Handle <ul style="list-style-type: none"> • Lock: locking in manual mode and for sealing the bag when turning foil rolls into bags. • Unlock: operational position with the lid opening automatically
16.	Attachment for vacuum sealing of Status vacuum containers and the marinating container. Used with a tube and connects a vacuum container to the vacuum packing machine.
17.	Sealing Strip It is coated in teflon foil and it double seals a bag.
18.	Position Marker/Barrier Indicates where to position the bag during the vacuum packing process.
19.	Grip on the Lid

1.6. TECHNICAL INFORMATION

Dimensions	length: 510 mm (with the cord attached: 570 mm) width: 288 mm height: 137 mm
Weight	approximately 8.9 kg
Material	stainless steel (external casing)
Pump	double piston pump
Vacuum pressure	up to - 900 mbar
Electric motor	230V ~, 50/60Hz Automatic shutdown in case of overheating
Maximum electric motor revolutions per minute	2900 rev/min
Transformer	230V~, 50Hz / 16V~, 6A (100VA) Automatic shutdown in case of overheating
Pump volume	30 litres/min
Controls	Electronic
Max. length of the sealing area	Dual sealing at 360 mm length
Rated power and voltage of the machine	400 W, 220-240 V~, 50/60Hz

2. USE

2.1. GENERAL INSTRUCTIONS

- a.) When removing the machine from the packaging ensure that all the components are included and that the machine and its accessories are in pristine condition.
- b.) **It is essential that you read the User Manual before first use.**
- c.) Place the machine on a level smooth surface with enough room to allow for placing foodstuffs into the bags.

When vacuum packing foodstuffs the machine has two basic modes of operation:

- The Auto mode is intended for automatic vacuum packing of solid and firm foodstuffs; this function is almost entirely automated – Button 2.
- The Manual mode is intended for vacuum packing more delicate, soft, and moist foodstuffs or for turning foil rolls into bags – Button 4.

NOTE: Cover of the machine has to be lifted when choosing Auto or Manual mode.

Handle on the lid:

The handle on the lid of the machine can be set in two positions. Place it in the appropriate position before

using the machine.

- Lock – the locked position is used for vacuum packing in manual mode and for sealing the bag when turning foil rolls into bags.
- Unlock for auto function, in this position the lid opens automatically.

In order to move the handle Lock/Unlock, press firmly on middle of the grip of the machine.

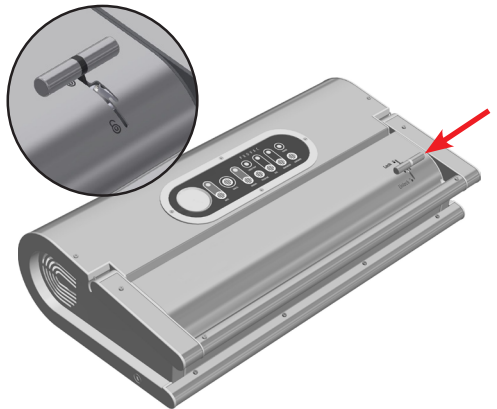

Figure 2: Handle.

2.2. PREPARING THE MACHINE FOR USE

2.2.1. ATTACH THE STATUS STIKI DOUBLE-SIDED ADHESIVE TAPE

- a.) Clean the surface of the area where the Status Stiki tape will be attached with alcohol or acetone. See Item 14 in Figure 1.
- b.) Peel off one side of the double-sided tape and attach it to the cleaned surface. Press firmly to allow for the glue to adhere.
- c.) Before using the machine peel off the upper side of the tape and Stiki is ready for use.
- d.) When operating the machine the vacuum bag is adhered to the Stiki tape (the bag adheres on contact – there is no need to press) and there is no need to worry about the bag moving.

- e.) Removal: When Stiki gets dirty or no longer adheres to the bag, remove it manually and attach a new one. The double-sided Status Stiki tape does not leave marks on the machine.



Figure 3: Make sure to always clean the surface before attaching Stiki.

RECOMMENDATION: Stiki tape allows you to freely vacuum seal several narrower bags at a time; the maximum bag-width (a single one or several together) is 36 cm. Furthermore, because the bag is attached far less of it is used than if it were merely positioned in place.

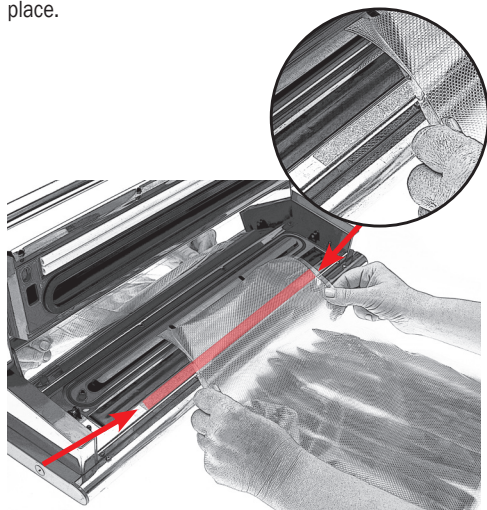

Figure 4: Always put the bag on the Status Stiki for easier placement of the bag.

2.2.2. TURN ON THE MACHINE

Turn the machine on by pressing the button on the right side of the machine (Item 11 in Figure 1). Make sure that the control light marked Power is on (Item 1 in Figure 1).

2.3. TURNING FOIL ROLLS INTO BAGS: SEAL BUTTON

Status foil rolls come in four widths: 200, 280 and 120 mm (for salami) and 350 mm.

- Determine the correct length of the foil by adding some extra centimetres to the length of the foods you intend to vacuum pack.
- Cut the foil with the attached blade.
- Using the Status Stiki tape, place the foil onto the wide sealing strip aligning it with the gasket (see detailed Figure 3).
- Press the Manual button. It will only work if the cover of the machine is lifted.
- Press the Seal button (Item 6 in Figure 1). During the sealing process the Seal button blinks and remains lit towards the end of the process.
- Once the light turns off, unlock the machine and open the lid.

During the sealing process the machine is completely silent and energy-efficient. Since it has two sealing bars Provac 360 does not need to be preheated before operation.

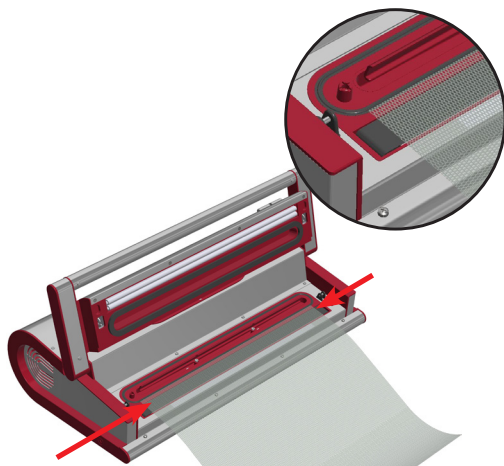

Figure 5: When sealing, position the bag on the sealing strip precisely and all the way to the gasket.

2.4. AUTO MODE: VACUUM PACKING SOLID AND FIRM FOODSTUFFS (CURED MEAT PRODUCTS, HARD CHEESES ...)

- Press the Auto button (Item 2 in Figure 1) to run the full cycle and achieve maximum negative pressure. Make sure the cover of the machine is lifted.
- Place the foods into a bag. The bag should always be longer than the length of the foodstuff, which is to be vacuum packed.
- Position the bag between the sealing gaskets; the position marker in the vacuum channel delineates where to position the bag.
- Use the Status Stiki tape to ensure that the bag remains in the correct place and without creases – see User Manual, 2.2.1..
- The handle on the lid should be in the Unlock position.
- Hold the grip on the lid, lower the lid and hold it in place for a few seconds.

When the lid is lowered the machine will:

- start automatically,
 - take control of the lid after a few seconds (when it reaches negative pressure of -300 mbar you can let go),
 - seal the bag (with a double seal),
 - after the sealing process is complete the lid will lift automatically.
- g.) The foods in the bag is vacuum packed and sealed with a double seal. To be removed, the bag needs to be detached from the Status Stiki double-sided adhesive tape.

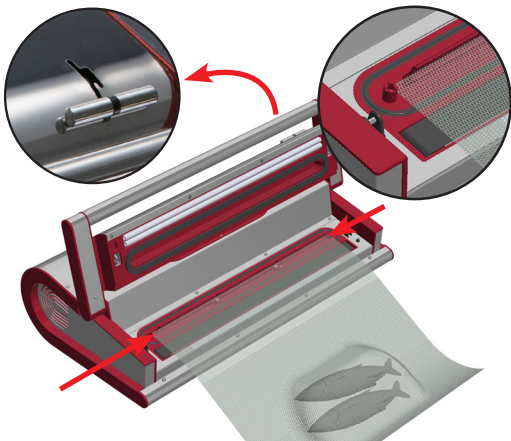

Figure 6: During the vacuum packing process the edge of the bag needs to reach all the way to the barrier in the middle of the vacuum channel.

***RECOMMENDATION:** When vacuum packing greasy cured meat products (particularly bacon), we advise that you first fold the edges of the bag outwardly before placing the foodstuff into the bag and then unfold the edges back into place. This will ensure that the edges do not become greasy.

HOW TO ACT IF THE MACHINE BEGINS TO DRAW LIQUID WHILE VACUUM PACKING?

If you notice that the machine is drawing liquid IMMEDIATELY stop the vacuum packing process by pressing the Cancel button (Item 3 in Figure 1). If the vacuum packing process is not stopped in time and the liquid enters the vacuum channel, the machine will automatically stop the vacuum packing process. The control light Liquid Trap will turn on.

- Open the lid. There is a container between the gaskets that must be lifted directly upwards.
- Pour the liquid out and thoroughly wipe the container in its entirety.
- Put the container back and continue with vacuum packing. If the liquid made its way into the channel container, wipe and dry the channel as well.

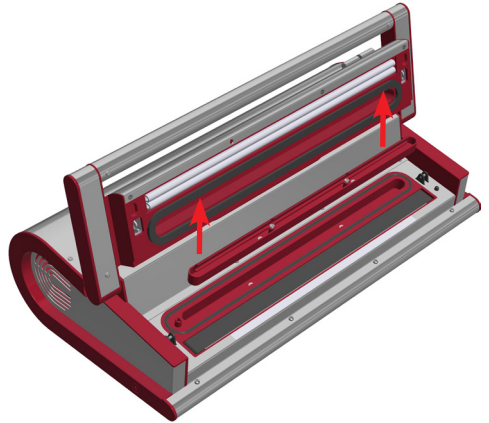

Figure 7: When liquid finds its way into the container, lift the container directly upwards, pour the liquid out, and dry the container thoroughly.

2.5. MANUAL MODE : VACUUM PACKING DELICATE AND SOFT FOODS (FRESH MEAT, FISH, VEGETABLES, FRUIT, CAKES, SOFT CHEESES ...)

Foods sensitive to pressure, moist foods and foodstuffs that contain high levels of moisture (fresh fruit, bread, cakes, mushrooms), should be conserved using lower levels of vacuum pressure (from 0 to -300 mbar).

Manual vacuum packing allows you to stop the process of suction when you determine that enough air has been extracted from the bag, before the tender foods incurs damage.

When vacuum packing soft and moist foodstuffs, keep in mind that you must pay particular attention to what is happening inside the bag.

To control how much negative pressure is introduced – i.e. the manual vacuum packing process – press the Manual button (Item 4 in Figure 1).

- a.) Place the bag between the gaskets all the way to the barrier in the middle of the vacuum channel (use the Status Stiki self-adhesive tape to ensure the bag will remain in the correct position).
- b.) Take the lid by the grip, lower the lid, and move the handle on the lid in the Lock position (simultaneously).
- c.) Vacuum pack by pressing the Pulse Vac button (Item 5) and finish the process by pressing the Seal button (Item 6):
 - When you hold Pulse Vac down the vacuum pump is running, when you release the button the operation stops. The intention is that we are able to achieve a specific negative pressure in the bag with several consecutive pushes. When you estimate that enough air has been extracted (observe what is happening to the foodstuff and when liquid is beginning to seep towards the machine, or when the soft foodstuff could become damaged) stop pressing the button (Item 5 in Figure 1).

- Once the desired negative pressure has been achieved, press the Seal button to begin the sealing process (the Seal light turns on and the machine remains silent).
- When the sealing process is concluded (the Seal light turns off), unlock the machine using the handle (Unlock) and the lid returns to its original position.



Figure 8: While in manual mode, handle has to be in lock position.

RECOMMENDATION: The simplest way to vacuum pack almost all sorts of fruit and most vegetables, fresh meats, mushrooms and the like, is to keep them in a freezer for a few hours before vacuum packing. This way foods, for example strawberries, will retain their shape completely and there will be no risk of liquid seeping into the vacuum channel.

2.6. MARINATING

Meat and fish are marinated faster in vacuum, since vacuum opens the pores of the food and allow the marinade to quickly and thoroughly penetrate deep into the food. By performing a series of consecutive vacuum packing and unpacking operations it is possible to achieve great effect in 18 minutes that would otherwise take several hours to attain.

NOTE: The tube with the vacuum packing attachment is not included and needs to be purchased separately. Any Status container can be used for marinating, though we recommend the 2-litre square or 2-, 3-, or 4.5 litre rectangular vacuum containers.

- a.) Connect the tube aperture to the attachment on the extreme left edge of the vacuum channel (Item 16 in Figure 1).
- b.) Connect it to the container for marinating (see Figure 9).
- c.) Press Marinator to start the marinating programme.

The programme is entirely automated and lasts 18 minutes all together. While the process of marinating "is running" the light Marinator blinks (Item 7 in Figure 1). Once the light turns off, the programme is concluded. 150 seconds of vacuum and 60 seconds of rest equals one cycle that is repeated five times.

While the process of marinating "is running" the light Marinator blinks.

After it is concluded, the machine enters stand by mode – the Power light turns on.

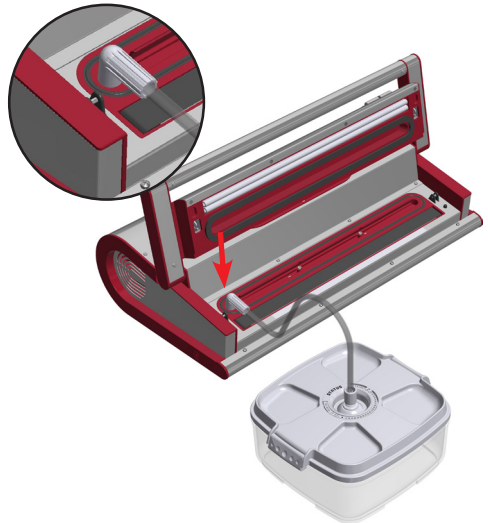

Figure 9: Marinating process.

2.7. VACUUM SEALING OF STATUS' VACUUM CONTAINERS AND LIDS

A tube with an attachment for the vacuum sealing of Status vacuum accessories (containers, lids and jug) is included in the set.

- a.) Connect the aperture of the tube to the attachment located on the extreme left edge of the vacuum channel.
- b.) Slide the attachment at the other end of the tube onto the valve of the chosen vacuum container (the valve is the round part at the centre of the lid).
- c.) Press Container (Item 8 in Figure 1). Once the pre-set negative pressure is achieved inside the container, the process ends automatically.

When using the vacuum containers to store liquid food-stuffs (soups, sauces, and similar), they should not be filled to the top. There should be a minimum of 1.5 cm distance between the surface of the liquid and the lid.

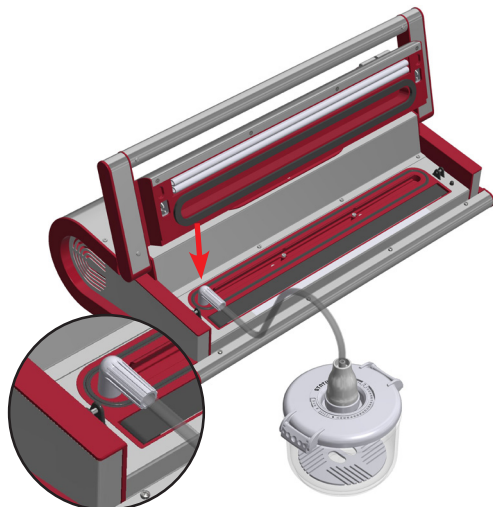

Figure 10: A depiction of the vacuum sealing of vacuum containers.

3. VACUUM PACKING DIFFERENT TYPES OF FOOD

Vacuum packing is not a substitute for freezing or refrigeration. Despite being vacuum packed foods still have to be stored in the refrigerator or freezer or in a cool place (e.g. dried meat products in a cellar).

Do not use bags or rolls for packing foods which contain a lot of liquid.

Soups, sauces and liquids should be either pre-frozen before packing in a vacuum bag or vacuum packed in a vacuum container.

Boiled meat, raw meat and fish: For best results we recommend you to pre-freeze meat and fish for 1-2 hours prior to vacuum packing to ensure the retention of juices and shape, and to help guarantee a good seal. If pre-freezing is not possible, place a folded paper towel between the meat and the top of the bag, avoiding the area to be sealed. Leave the paper towel in the bag when vacuum packing to absorb excess moisture and juices.

Note: Beef may appear darker after vacuum packing due to the removal of oxygen. However, this does not indicate it is spoiled.

Vegetables: When storing in the refrigerator vegetables should be blanched prior to vacuum packing. When freezing the blanching is optional. The process of blanching stops the enzyme action and preserves flavour, colour and texture. One to two minutes in boiling water is enough for fresh leaf vegetables or beans. For chopped zucchini or broccoli and other cruciferous vegetables allow 3 to 4 minutes, for carrots allow 5 minutes. After blanching, submerge the vegetables in cold water to stop the process then dry them with a paper towel prior to vacuum packing.

We recommend you to store leaf vegetables in vacuum containers. They should first be washed and dried with a paper towel, and then stored in a vacuum container. This way, spinach and lettuce will stay fresh up to 2 weeks when refrigerated.

Herbs: Herbs containing a high portion of essential oils, such as sage, thyme, rosemary or peppermint are not suitable for vacuum packing but only for drying. Basil, tarragon, garden dill, parsley and chive should be frozen. If dried, they lose too much flavour.

Mushrooms, raw garlic and raw potatoes: We strongly recommend the "manual vacuum packing" function. Only hard, meaty and fresh mushrooms are suitable for vacuum packing and freezing. First wash and dry the mushrooms, then chop them with a fine knife and store them in small quantities. Almost all types of mushrooms should be blanched. We recommend that you put them in the freezer for half an hour before vacuum packing. Do not thaw the mushrooms before preparing them. Boil frozen mushrooms in hot salty water or add them to sauces.

Coffee: If you want to properly vacuum package coffee or other ground food with Provac 360, leave the items in their original packaging and place them into the Status' bag. If you do not have the original packaging, use a regular bag and insert it in the Status' bag. This way you can prevent beans or ground items from being sucked into the machine.

Thawing of vacuum packaged foods: Foods should always be thawed in the refrigerator to preserve quality.

4. BENEFITS OF VACUUM PACKING

4.1. WHAT IS VACUUM?

Oxygen provokes a chemical change on food and is an important factor in the formation of moulds and bacteria. As a consequence, grease can go rancid, food colour changes, moulds and bacteria multiply, and flavour, vitamins, aroma and minerals are lost. Vacuum packing holds up such undesired

effects, prolongs shelf life and preserves food quality. Only with the help of vacuum packing, i.e. removing air from packing using manual or pump, a suitable environment required to extend food freshness can be established. The process of vacuum packing in containers or bags creates negative pressure.

4.2. WHAT IS FREEZER BURN?

Signs of freezer burn are rancid meat, rotten vegetables and tasteless fruit. Freezer burn appears, when the packaging is permeable to air (common 1 ply PE bags) and frozen food comes into contact with oxygen. Consequently, water evaporates and the surface

of frozen food dries out. Oxygen penetrates through the porous cracks and initiates oxidation. As a consequence, food loses its aroma and fresh taste. We can recognize freezer burn by the white and dun stains on the food.

4.3. DEEP FROZEN OR CHILLED

The advantage of storing deep frozen food is in preserving its essence – vitamins, minerals and taste. Besides, at temperatures between -30°C and -40°C the texture of raw food changes only to a minimum extent (e.g. meat). Freeze food as quickly as possible.

Reason: When you are freezing food slowly, big ice crystals are formed on the surface. They overgrow food cells and subsequently damage their structure. When you are freezing food quickly, small ice crystals are formed, which do not damage the food to such an extent. If possible, freeze food at constant temperature (-18°C at the most). Only food of the

highest quality should be frozen. Some foods have to be blanched (scalded) in order to avoid unwanted changes when freezing or deeply refrigerating (enzyme activation, ceased germination). Blanched or in any other way heat treated foods must be chilled before freezing. Otherwise, already stored food can start thawing and become damaged or vacuum can be lost when storing food in vacuum containers. To ensure better quality of stored fruit, use sugar as additive. This also preserves aroma and colours. In the freezer, containers should be kept together as close as possible. The rest of them can be kept in the refrigerator.

4.4. THAWING

Thawing should be a slow (the most suitable way of thawing is in the refrigerator) and natural process. It should not be forced (as it is when putting a bag into hot water or thawing food in the microwave). Once the food is defrosted, it should not be refrozen. When refreezing, mechanical damages occur and food can perish

more quickly. Taste, colour and aroma are decomposed. Micro-organisms (bacteria, mould) multiply much faster. These consequences cannot be eliminated by refreezing. It is therefore recommended that once the foods are thawed, they should be used as soon as possible.

4.5. SOUS VIDE COOKING

Cooking Sous Vide is a modern cooking technique where we cook food in vacuum packed bags immersed in hot water. The Sous Vide technique provides a superior flavour of your home-cooked food, where foods optimally retain their natural taste, colour and texture.

Make sure to use Pulse vac function for vacuum packing and to use high quality Status vacuum bags.

The best Sous Vide vacuum bags on the market are the ones that have the perfect combination of materials (airtight polyamide and food-grade polyethylene) and where the thickness of materials is just right. Status' bags perfectly fulfill both of these characteristics.

Food for Sous Vide cooking can also be prepared in advance before freezing, for example adding spices and herbs into the vacuum bag together with meat.

4.6. SAILING, CAMPING AND PICNICKING

Vacuum packing is also suitable for picnics, sailing and camping. Food, equipment and documents stay dry and protected. Batteries, mobile phones and cameras can also be vacuum packaged to keep them from getting

wet. Vacuum packing prevents mixing of odours and keeps food from perishing due to moisture. This is particularly important in small spaces.

5. WHY USE STATUS' BAGS AND FOIL ROLLS?

Status vacuum bags are impermeable, food safe, neutral in taste and smell, reusable, BPA free and suitable for Sous Vide cooking. The foodstuffs stored in them will remain the same at least half a year after you have stored it.

The quality of a bag and a foil roll is determined by the thickness of the bag, the combination of materials and the height of the ribbed profile.

The thickness of the bag Status' bags are characterized by a 100 µm thick smooth foil and a 130 µm thick ribbed foil. Their embossed criss-cross pattern helps that the air is removed more effectively during the vacuum sealing process.

The combination of materials, of polyamide and polyethylene, affects the (im)permeability of the bag. Polyamide is the material that affects the permeability

of a bag the most, while the passage of oxygen through the bag affects the quality of stored food. Compared to competing brands Status' bags and foils boast the thickest layer of polyamide (30 µm) which makes them the most quality option for storing food.

The height of the ribbed profile determines the quality of vacuum packing. Status' bags feature at least 0.2 mm high ribbed layer which enables them all to be vacuum sealed uniformly whether it be the first of the 50th vacuum cycle. Thinner bags can be vacuum sealed well during the initial few cycles (maximum of 10 bags) but later even the quality vacuum packing machines cannot establish vacuum or generate enough negative pressure.

Bags and foil rolls are compatible with all brands of vacuum packing machines.

BAG STRUCTURE

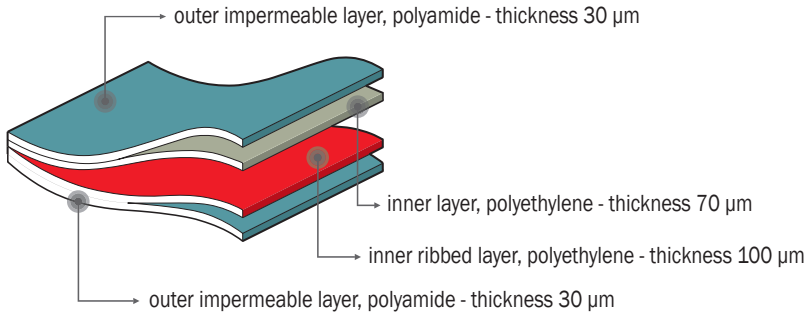

VACUUM BAGS AND FOIL ROLL SETS

Foil roll	4 ply foil (PA/PE) <ul style="list-style-type: none"> length 3000 mm x width 200 mm, 4-piece set length 3000 mm x width 280 mm, 3-piece set length 3000 mm x width 120 mm (for salami), 5-piece set length 3000 mm x width 350 mm, 3-piece set
Bags for vacuum packing	4 ply foil (PA/PE) <ul style="list-style-type: none"> length 280 mm x width 200 mm, 40-piece set and 100-piece set length 360 mm x width 280 mm, 25-piece set and 100-piece set length 550 mm x width 120 mm (for salami), 30-piece set and 100-piece set length 400 mm x width 350 mm, 25-piece set and 100-piece set
Thickness of the foil	100 µm (smooth, unribbed part) and 130 µm (structured ribbed part of the foil)
Quality of the foil	Impermeable, two-ply, food-grade, neutral in taste and smell, reusable, microwave safe, appropriate for Sous Vide cooking.

6. COMPARATIVE STORAGE TABLES

Source: Status' Development Dept. manufacturer

6.1. COMPARATIVE TABLE OF FOOD STORAGE IN THE REFRIGERATOR

Type of food	Regular storage	Vacuum storage
Boiled food	2 days	10 days
Fresh meat	2 days	6 days
Fresh poultry	2 days	6 days
Boiled meat	4-5 days	8-10 days
Fresh fish	2 days	4-5 days
Cold meats	3 days	6-8 days
Smoked sausages	90 days	365 days
Hard cheeses	12-15 days	50-55 days
Soft cheeses	5-7 days	13-15 days
Fresh vegetables	5 days	18-20 days
Fresh herbs	2-3 days	7-14 days
Washed lettuce	3 days	6-8 days
Fresh fruit	3-7 days	8-20 days
Desserts	5 days	10-15 days

Tip: Before vacuum packing properly chill the food.

6.2. COMPARATIVE TABLE OF FOOD STORAGE IN CUPBOARDS AND ON SHELVES

Type of food	Regular storage	Vacuum storage
Bread/rolls	2-3 days	7-8 days
Pastry	120 days	300 days
Dried food	10-30 days	30-90 days
Raw rice/pasta	180 days	365 days
Coffee/tea	30-60 days	365 days
Wine	2-3 days	20-25 days
Non-alcoholic drink (sealed)	7-10 days	20-25 days
Non-alcoholic drink in a vacuum jar	2-3 days	7-10 days
Baking goods	2-3 days	7-10 days
Hazelnuts, walnuts etc.	30-60 days	120-180 days
Crackers/potato chips	5-10 days	20-30 days

6.3. COMPARATIVE TABLE OF FOOD STORAGE IN THE FREEZER

Type of food	Regular storage	Vacuum storage
Fresh meat	6 months	18 months
Ground meat	4 months	12 months
Poultry	6 months	18 months
Fish	6 months	18 months
Fresh vegetables	8 months	24 months
Mushrooms	8 months	24 months
Herbs	3-4 months	8-12 months
Fruit	6-10 months	18-30 months
Cold meats	2 months	4-6 months
Baking goods	6-12 months	18 months
Coffee beans	6-9 months	18-27 months
Ground coffee	6 months	12-34 months
Bread/rolls	6-12 months	18-36 months

Only approximate time of duration is indicated in the tables, as it depends on the initial state (freshness) and way of preparing food. We have considered storage of food at +3 °C / +5 °C in the refrigerator and at -18 °C in the freezer.

7. TROUBLESHOOTING

PROBLEM:	WHAT TO DO:
Provac 360 does not respond when I press the buttons.	<ul style="list-style-type: none"> • Make sure the machine is switched on and plugged in. • If socket is on but you have no power, check the socket with another machine that you know works. • Check the power cord for any damage – cracks or splitting.
Seal function does not work.	<ul style="list-style-type: none"> • Check if the Manual button is on (indicated by a light). • Check if the handle is in the Lock position.
Pulse Vac function does not work.	<ul style="list-style-type: none"> • Check if the Manual button is on (indicated by a light). • Check if the handle is in the Lock position.
You pressed the wrong button.	<ul style="list-style-type: none"> • Use the Cancel button to stop all the operations and the machine will revert to standby mode. • Start the process from the beginning (choose between Auto/Manual, set the handle in the appropriate position Lock/Unlock) and press the button of your choosing.
Air remains in the bag.	<ul style="list-style-type: none"> • Make sure you have placed the entire open end of the bag in the middle of the vacuum channel. • Ensure that the bags you are using have at least 100/130 µm thickness. • Check your bag for any damage – splits, perforations or bubbles. • Test: Seal bag and submerge it in water. Bubbles will appear if the bag is damaged. • When using foil rolls make sure that the first sealing edge is firmly sealed.

PROBLEM:	WHAT TO DO:
The vacuum doesn't hold on the bags.	<ul style="list-style-type: none"> • Check if the sealing areas of the lid are free from any dirt, grease, or food particles, and that they are firmly in place. • Ensure that the edges of the bag are perfectly clean – thoroughly remove any food particles or liquid and ensure that the bag is completely dry. • If you are sealing anything with sharp edges (e.g. bones) make sure they cannot pierce the bag during the vacuum process. • Note: cover sharp edges with a paper towel, or similar, prior to sealing.
Bag melts or cannot be sealed completely.	<ul style="list-style-type: none"> • Make sure you are using bags that are at least 100/130 µm thick and two-ply. • Before sealing ensure that the edges of the bag are clean and dry.
Provac 360 sealed several bags (up to 5 items) and it seems it is not working anymore. Important note about vacuum bags:	<ul style="list-style-type: none"> • We strongly recommend vacuum bags at least 100/130 µm thick. There are many different types of vacuum bags available on the market so pay special attention to quality. Our recommendation is to use original vacuum bags from Status, which are two-ply and 100/130 µm thick.
The vacuum doesn't hold when using a container.	<ul style="list-style-type: none"> • Ensure that your Hose is correctly inserted as shown in Figures 9 and 10. • Make sure your container lid is clean and dry and in the correct position. • Make certain that your container valve is clean and dry.
How do I know the marinating process is completed?	<ul style="list-style-type: none"> • Observe the light on the machine. • When the process ends, the Marinator light stops blinking and the machine goes into standby mode (green Power light turns on).

8. WARRANTY

This warranty is valid for **two years** from the date of purchase. Evidence of original purchase is required for warranty services, so it is important to keep your sales receipt.

This warranty only covers breakdown caused by electrical or mechanical failure. It does not cover damage caused by liquid entering the machine or breakdown caused by failure to follow the manufacturers instructions.

If you have any comments or questions concerning the functioning of the machine or warranty, please contact us:

STATUS d.o.o. Metlika
Ulica Belokranjskega odreda 19, 8330 Metlika,
Slovenia
Customer phone: +386 736 91 228
E-mail: info@status.si

For more information visit our website
<http://innovations.status.si/>.

9. DECLARATION OF CONFORMITY

The machine complies with all European directives:

- a.) Rules on Electrical Equipment Designed for Use within Certain Voltage Limits
(Official Journal of RS, Nos. 27/2004, 17/2011, 71/2011)
LVD Directive 2014/35, 2006/95/EC
- b.) Rules on Electromagnetic Compatibility
(Official Journal of RS, Nos. 84/2001, 32/2002, 132/2006)
EMC Directive 2014/30, 2004/108/EC

EC declaration of conformity guarantees that the machine is safe and has been inspected and tested to meet all the requirements specified in the applicable standards, directives and regulations.

EC Declaration of conformity for CE marking is located at the seller and can be provided per customer's request.

10. CORRECT DISPOSAL OF YOUR VACUUM MACHINE

When the equipment or parts of the device are no longer fit for use they must be disposed of at the industrial waste landfill in accordance with applicable regulations:

- Decree on the Management of Waste Electrical and Electronic Equipment (WEEE) (Official Journal of RS, no. 107/2006)
Directive 2012/19/EU on Waste Electrical and Electronic Equipment (WEEE)
- Rules on the Restriction of the Use of Certain Hazardous Substances in Electrical and Electronic Equipment (RoHS) (Official Journal of RS, no. 102/2012)
- Rules amending the Rules on the Restriction of the Use of Certain Hazardous Substances in Electrical and Electronic Equipment (Official Journal of RS, no. 20/2014)
Directive 2011/65/EU on the Restriction of the Use of Certain Hazardous Substances in Electrical and Electronic Equipment

Environmentally hazardous components and parts that were built into the device have to be disposed of at specialized sites.



The symbol on the product or its packaging indicates that at the end of its life, the product may not be treated as ordinary household waste and must be disposed of in accordance with your local authority's instructions and at properly designated sites. You can also

use an official WEEE collection service provider in accordance with directive 2002/96/EC.

Separate collection of individual components of EE equipment prevents negative effects of environmental pollution and minimizes danger to human health, which may occur as a result of improper product disposal. In addition, it enables reuse and recovery of the material, thus saving energy and raw materials. For detailed information on collecting, sorting, reuse and recycling of the product contact the provider of WEEE collection services or the shop where you bought the equipment.

The date of manufacture can be found on the warranty sheet which you received at purchase.

11. STATUS PROVAC 360 SET

The set includes:

- 1 STATUS PROVAC 360 professional vacuum packing machine
- 1 Foil Roll - 280 mm (W) X 3000 mm (L)
- 1 Foil Roll - 350 mm (W) X 3000 mm (L)
- 5 Vacuum Bags - 200 mm (W) x 280 mm (L)
- 5 Vacuum Bags - 120 mm (W) x 550 mm (L)
- 5 double-sided Status Stiki adhesive tapes
- 1 Connector used for vacuum packing of containers
- 1 Manual Cutter used for cutting foil
- 1 User Manual

