

# MALMET

## MALMET BEDPAN/URINAL BOTTLE WASHER DISINFECTOR

Malmet ES-D Series Bedpan/Urinal Bottle Washer Disinfector range is the most efficient and effective method of washing and disinfecting bedpans and urinal bottles. Independently micro-tested, Malmet ES-D Series are proven to inactivate organisms (bacteria and viruses) generally found in bedpans and urinal bottles.

The detergent wash ensures that faeces, etc are properly removed before the final steam disinfection, ensuring efficacy to the highest relevant Australian and ISO standards. Also designed with the environment in mind, the ES-D Series has one of the lowest energy usage rates in the industry.

- Low water and power consumption
- Large capacity: 1 bedpan and 2 urinal bottles per cycle
- Standard universal rack will also accept bariatric slipper pan
- Detergent cycle
- Infection Control: Microbiologically tested by an independent NATA certified laboratory
- Hands-free operation to minimise infection control risk
- Simple controls, easy to operate
- Steam disinfection with inbuilt boiler – no external hot water supply required
- Disinfection to higher A<sub>0</sub>600 level as recommended by AS4187:2014/ISO15883
- No venting required
- Available in 240V 10A and 240V 20A
- Compliant to relevant electrical safety and Watermark standards
- ARTG Certification 232012 to industry highest Class IIb level
- Malmet Door Obstruction Feature - This is factory set to 12Nm ±10%; causing the door to re-open when an obstruction is detected. This is designed to protect the integrity of the machine and the articles within.

<b>UNIT DIMENSIONS:</b>	595mm (W) x 650mm (D) x 1305mm (H)	
<b>VOLTAGE:</b>	240V; 10 Amp or 20 Amp	
<b>PHASE:</b>	Single	
<b>HERTZ:</b>	50	
<b>SHIPPING WEIGHT:</b>	110 kg	
<b>CAPACITY:</b>	1 x bedpan and lid and 2 x urinal bottles OR 1 x commode bowl and lid and 2 x urinal bottles OR 1 x small or bariatric slipper pan and lid and 2 x urinal bottles	
<b>DETERGENT BOTTLE CAPACITY:</b>	5 litre (Malmet Product Code 81-9071SP) Detergent ARTG Certification 190013	
<b>DETERGENT DISPENSED PER APPLICATION:</b>	30 ml	
<b>DETERGENT SPECIFICATIONS / GRADE:</b>	Poisons Schedule: 6 Dangerous Goods Class: 8 Hazchem Code: 2R	
	<b>10 Amp models</b>	<b>20 Amp models</b>
<b>AVERAGE CYCLE TIME:</b>	7.50 minutes	5:30 minutes
<b>POWER CONSUMPTION:</b>	0.236 kW/hr	0.300 kW/hr
<b>WATER CONSUMPTION:</b>	36 litres	
<b>ACCESSORIES:</b>	ES-D Cradle 1 litre jug holder (Product Code 91-5056)	



AVAILABLE MODELS	Product Code	Model No	Description
	91-1002	ES915S-D	MALMET BEDPAN/URINAL BOTTLE AND UTENSIL/BOWL WASHER DISINFECTOR (S TRAP, 1 PHASE, 20 AMP)
	91-1007	ES915P-D	MALMET BEDPAN/URINAL BOTTLE AND UTENSIL/BOWL WASHER DISINFECTOR (P TRAP, 1 PHASE, 20 AMP)
	91-1022	ES935S-D	MALMET BEDPAN/URINAL BOTTLE AND UTENSIL/BOWL WASHER DISINFECTOR (S TRAP, 1 PHASE, 10 AMP)
	91-1027	ES935P-D	MALMET BEDPAN/URINAL BOTTLE AND UTENSIL/BOWL WASHER DISINFECTOR (P TRAP, 1 PHASE, 10 AMP)

APPLICABLE MODELS	
MODEL NUMBER	DESCRIPTION
91-1002	ES-D915S
91-1007	ES-D915P
91-1022	ES-D935S
91-1027	ES-D935P
Chamber Capacity	
Usable	50 Litre
Total	60 Litre
Operating Weight	122 Kg

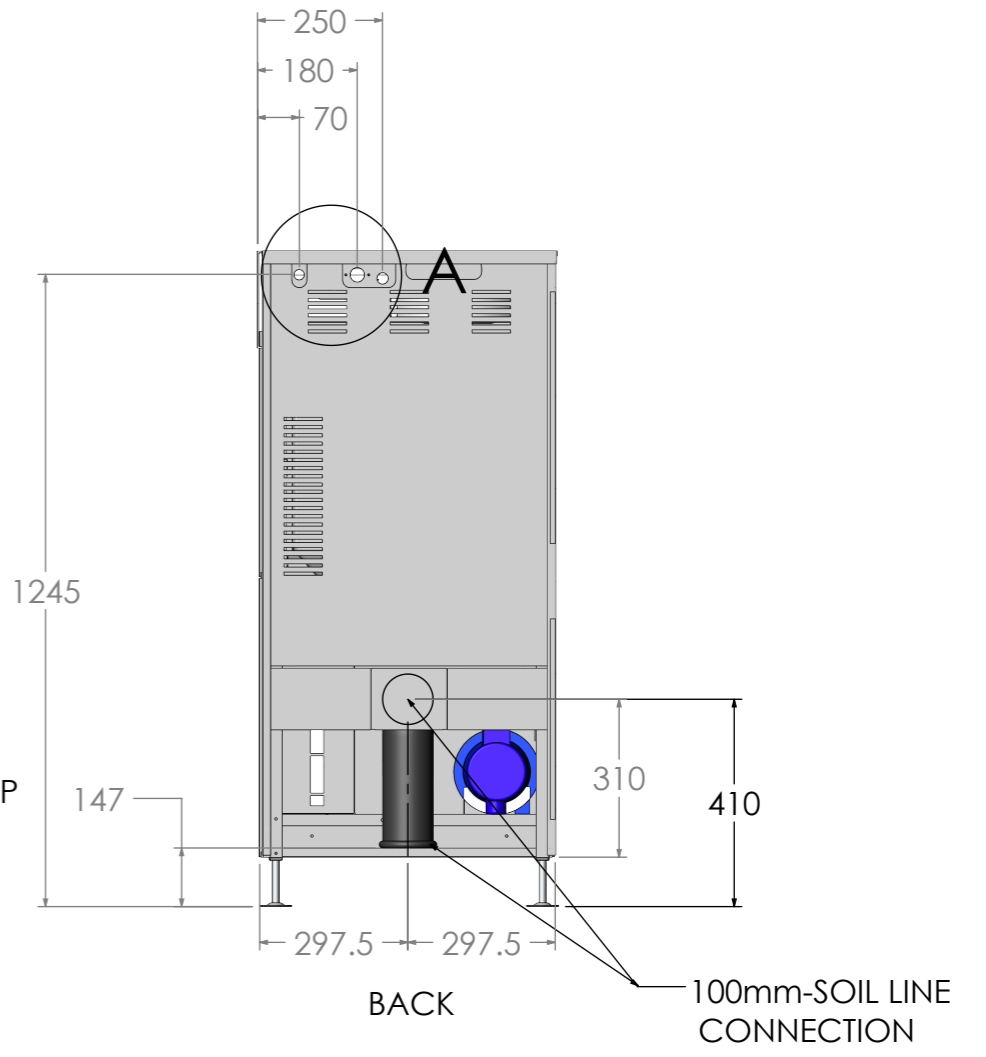
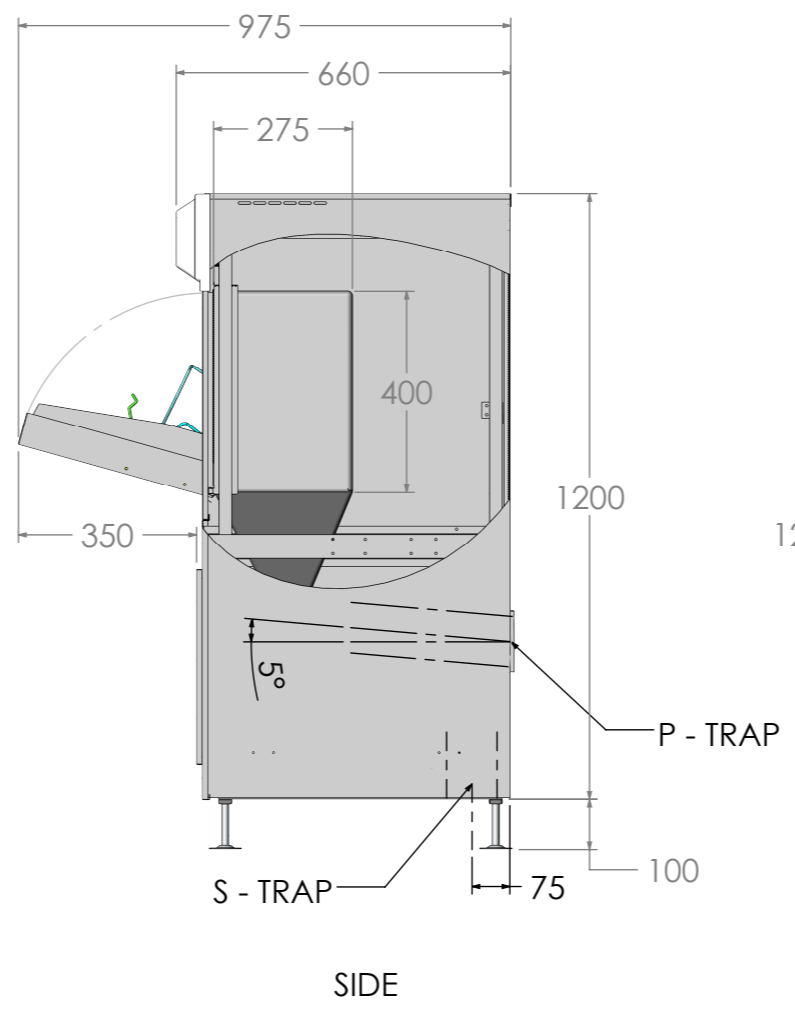
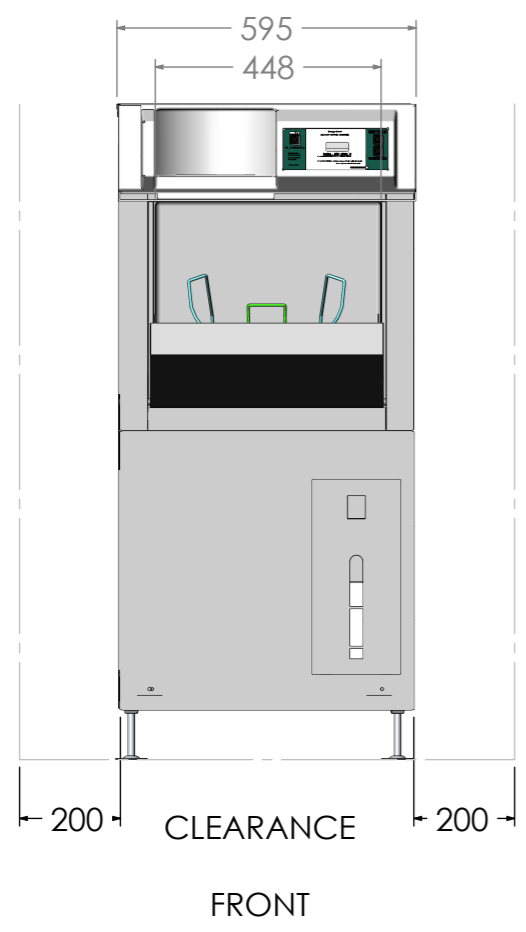
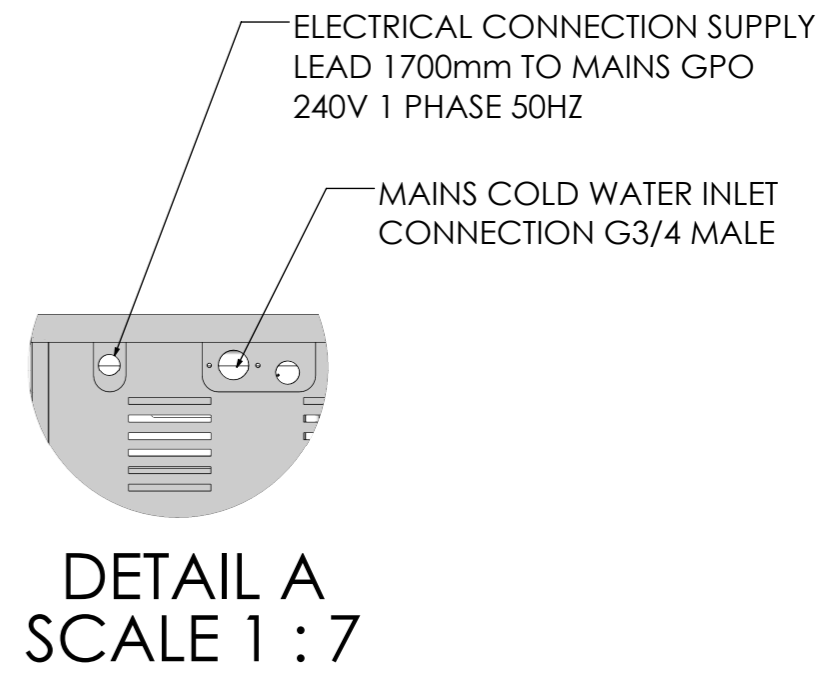
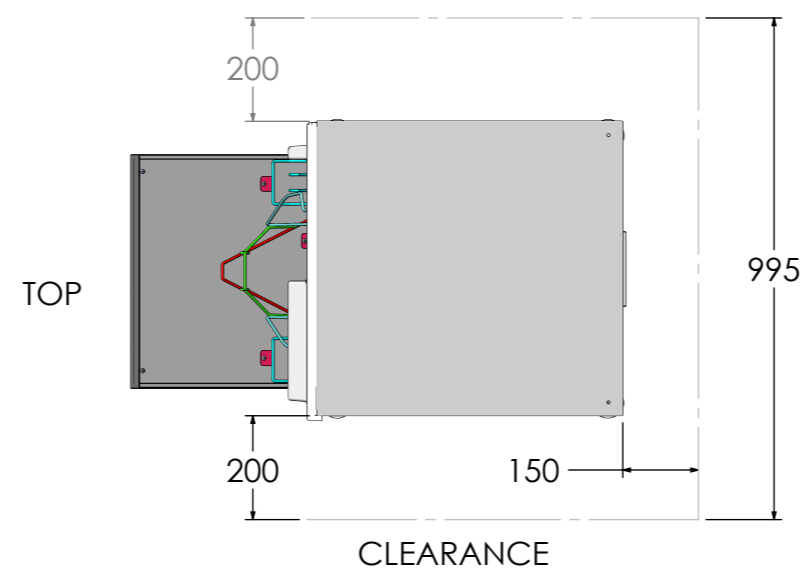

							<b>MALMET</b>		Installation Layout & Service Conection			ES-D915/935		
				TOLERANCE UNLESS NOTED			THIRD ANGLE PROJECTION		MATL.		FINISH		Date 15-8-2019	
				DIMENSIONS ± 0.25			DIMENSIONS IN MILLIMETRES		AS NOTED		AS NOTED		Scale 1:1 DRN AS ISSUE	
				ANGLES ± 0.25°			DO NOT SCALE						CKD APP	
01	15-8-2019	PRODUCTION APPROVED		AS	JJ	JJ							01 A3	
ISSUE	DATE	CHANGE	E.C.N	DRN	CKD	APP								

THIS DRAWING IS COPYRIGHT. COPYING IN WHOLE OR IN PART IN TWO OR THREE DIMENSIONS IS EXPRESSLY FORBIDDEN EXCEPT WITH PRIOR WRITTEN PERMISSION.