

## TWO STATION WELDING CELL

Fanuc ArcMate with Kemppi Welding Equipment

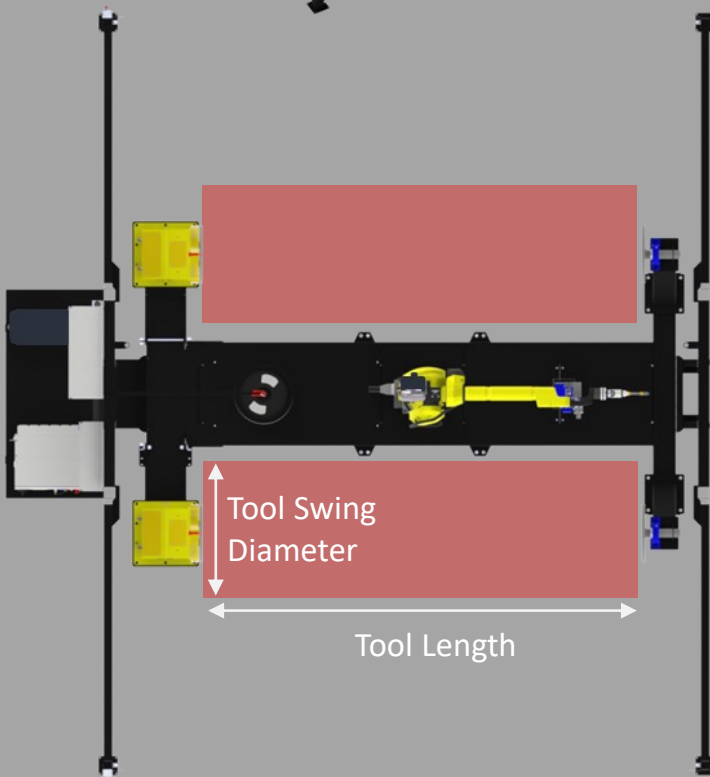
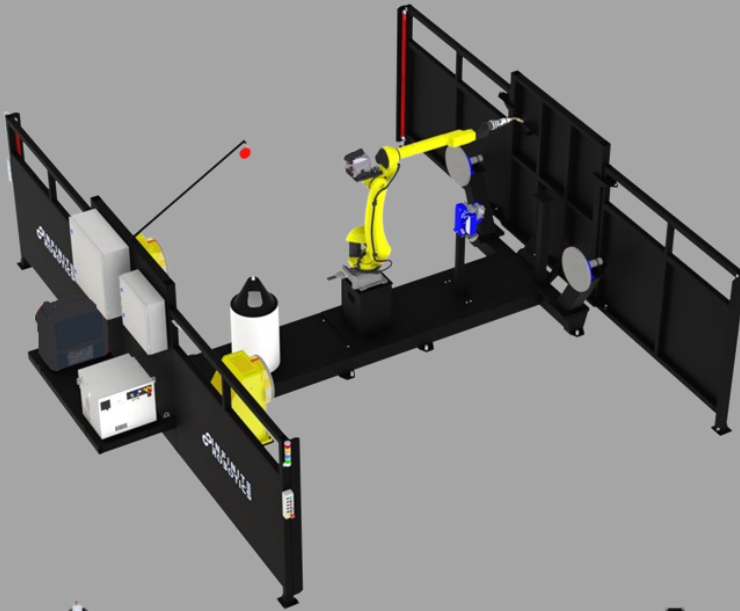

### Key Features:

- Fanuc ArcMate industrial welding robot
- Kemppi Robotic Welding Equipment
- Maximises arc-on time
- Pre-engineered, proven design
- Installation, commissioning and onsite training

### Standard Specifications:

- Headstock Payload: 500/1000/2000kg
- Tool Length: 2400/3000/3800mm
- Tool Swing Diameter: 1200/1500mm
- Welding Process: GMAW, MCAW, FCAW, GTAW
- Kemppi AX water cooled multi process welding power source