

W22L100-EHA3

21.5" Multi-Touch Panel Mount Display



KEY FEATURES

- 21.5", 1920 x 1080
- VGA and HDMI input
- Panel Mount
- VESA mount
- PCAP touch



SPECIFICATIONS

Display	
Resolution	1920x1080
Contrast Ratio	3000:1
Display Color	16.7M Colors
Active Area	476.64x268.11 mm
Size	21.5 inches
Panel Brightness	250.0 nits
View Angles	89,89,89,89
Touch / Glass	Projected Capacitive Multi Touch Screen Anti-glare Coating (Optional)
Environment	
Operating Humidity	10% to 90% RH, Non-Condensing
Storage Temperature	-10°C to 60°C
Operating Temperature	0°C to 50°C
IP rating	Front IP65
Certification	
Certification	CE, FCC
IO Ports	
USB Port	1 x USB for Touch Screen
Audio	Audio line in (3.5mm) (Optional) 2 x Speaker (Optional)
Video	1 x VGA 1 x HDMI (Optional) 1 x DVI (Optional)
Mechanical	
Dimension	531 x 322 x 59 mm
Mounting	VESA Mount/ Panel Mount
Cooling System	Fanless Design
Weight	6.4 kg
Enclosure	Metal Housing with Aluminum Bezel
Accessory	
Accessory	1 x VGA cable 1 x HDMI cable 100~240V AC to DC Adapter Power Cord Manual VESA screws(Varies by product)
Optional Accessory	Remote Controller (Optional,Varies by product)
Power	
Power Rating	12V DC in 24V DC in (optional)

Control

Button 5 Keys: -, +, Power, Esc, Enter

DIMENSIONS UNIT:MM

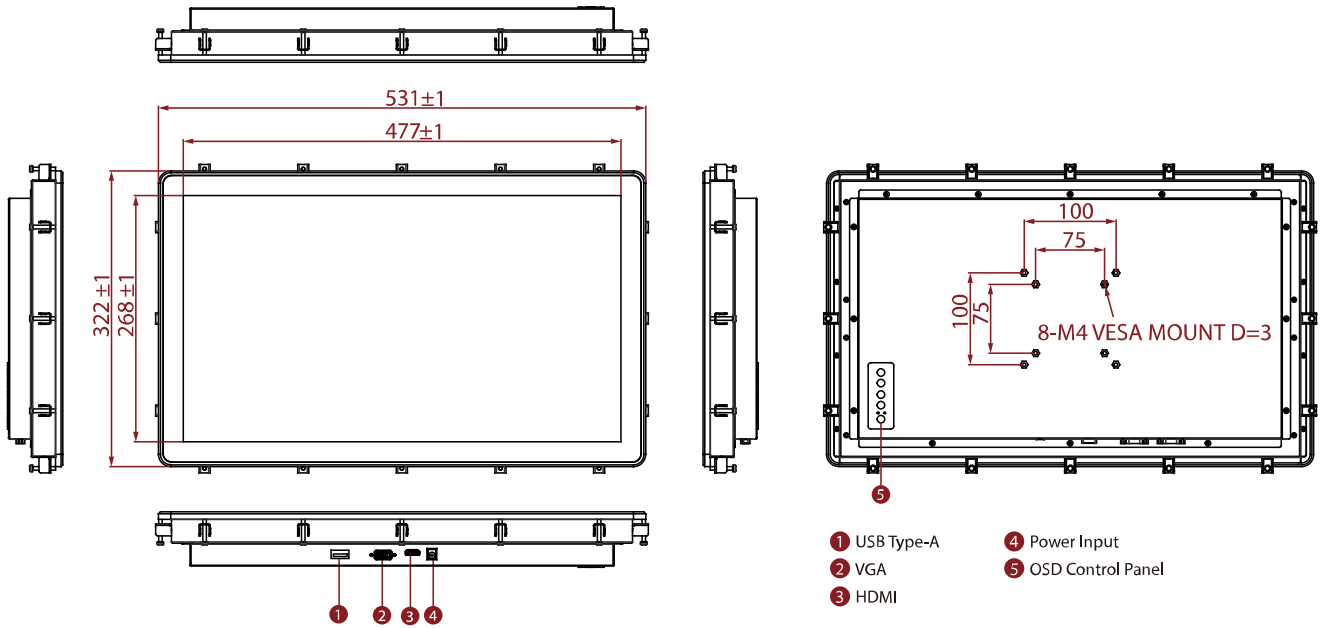

NOTE

1. This is a simplified drawing and some components are not marked in detail.
2. Please contact our sales representative if you need further product information.
3. All specifications are subject to change without prior notice.
4. The product shown in this datasheet is a standard model. For diagrams that contain customized or optional I/O, please contact the Winmate Sales Team for more information.