



MKN stacked combi steamers compact 2x6 tray, GN1/1 with MagicPilot operation system.

Product Advantages:

- **MagicPilot** – Robust, wear-free, capacitive true colour touch screen.
- **Video assist** – Interactive user assistance with clips featuring professional chefs.
- **CombiDoctor** – Self-diagnosis programme.
- Hygienic rounded corners and cooking chamber door with insulated **triple glazing**.
- **RackControl** – Multi-timer.
- **GreenInside** – Indicates the energy and water consumption for each cooking programme.
- **AutoChef** – Up to 350 individual cooking programmes and manual operating system.
- USB interface.
- High speed centrifugal steam generation technology with heat recovery.
- **ClimaSelect** – Humidity and temperature control measurement.
- **WaveClean** – Automatic cleaning system (safe, easy, economical).
- 3 years warranty parts and labour.

Installation requirements:

- Soft Water / Water supply / Connection to waste water provided by customer.
- If mineral content is high, reverse osmosis system may be advisable.

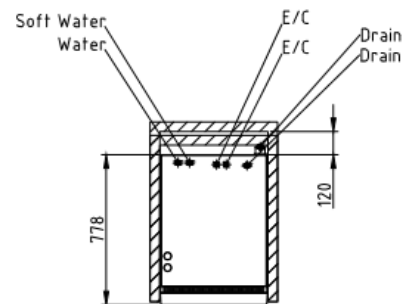
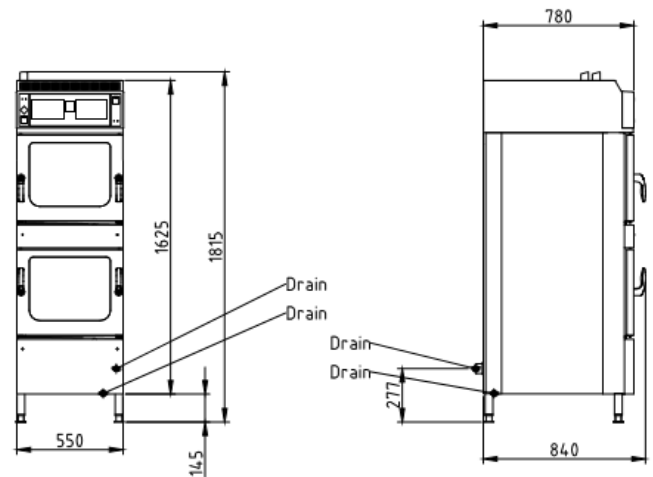

Technical Data:

Width x Height x Depth (mm)	550 x 1815 x 840
Connected load (electrical) (kW):	2 x 7.8
Voltage (V) / EC:	2x 415 3 phase AC
Recommended fuses (A):	3 x 20 + 3 x 20
Frequency range (Hz):	50
Soft Water connection:	DN 20 (R ¾" inside)
Water connection:	DN 20 (R ¾" inside)
Waterpressure (kPa):	200 -600 (2 - 6 bar)
Drain connection:	DN 40
Gastronorm 1/1 (530 x 325 mm):	6 + 6 (max. 60 mm deep)
Plates Ø 28 cm:	12 + 12
Material housing:	1.4301
Material cooking chamber:	1.4301
Net weight (kg):	215
Consumption steaming (l/h)	7.5
Consumption cleaning (l)	1.3
Type of protection:	IPX 5