



Pioneer® Series

Analytical and Precision Balances



The Best Balance For Basic Weighing!

The OHAUS Pioneer Series of analytical and precision balances are designed for basic routine weighing in a variety of laboratory, industrial and education applications. With the right combination of performance and features, the OHAUS Pioneer offers uncomplicated performance for all your basic weighing needs.

Standard Features Include:

- **Easy to Clean Analytical Draftshield** — Pioneer's draftshield is designed with all glass panels, including three sliding doors. All panels are easy to remove and replace, and together with a stainless steel bottom, make it fast and easy to clean
- **Upfront Level Indicator** — Pioneer has been designed with an up-front level indicator, so that users can quickly ensure the balance is level prior to use
- **Selectable Environmental Settings** — Three filter modes and adjustable zero tracking adjust balance sensitivity to environmental disturbances, or application requirements

Pioneer[®] Analytical and Precision Balances

Removable Doors Provide Convenient Access and Easy Cleaning

To address the ease of cleaning requirement often expressed by routine users, Pioneer's draftshield has been designed with easy to remove doors and panels. Disassembly takes just seconds and all components including the balance housing can be quickly wiped clean.



Periodic cleaning made easy helps avoid sample contamination and extends product life. In addition, a standard in-use cover provides added protection against accidental spillage and helps minimize the chance of damage to the display and keypad.

Should breakage occur, each replacement door or panel can be installed in seconds. A standard in-use cover provides added protection against accidental spillage.



Upfront Level Indicator Ensures Accuracy

The Pioneer has been designed with an up-front level indicator, eliminating the need to look behind the balance during the leveling process. A quick glance at the up-front level indicator helps you ensure that the balance is level prior to each use.



Selectable Environmental Settings For Working in Practically Any Condition

To help adapt the balance to real life working conditions, Pioneer is designed with selectable environmental settings. When working in harsh environments, the balance can be adjusted to compensate for vibrations and other disturbances. Conversely, the balance can be adjusted for working in slow filling applications where sensitivity is a must.

Model	PA64	PA114	PA214	PA153	PA313	PA512	PA1502	PA3102	PA4101
Capacity (g)	65	110	210	150	310	510	1500	3100	4100
Readability d (g)	0.1 mg			0.001		0.01			0.1
Repeatability (Std Dev)	0.1 mg			1 mg		10 mg			100 mg
Linearity	0.2 mg		0.3 mg	2 mg		20 mg			100 mg
Application Modes	Weighing, Parts Counting, Percent								
Weighing Units	mg, g, ct, oz, dwt, tical, tola, mommes, baht, grain, mesghal, Newton, ozt				g, lb, ct, oz, dwt, tical, tola, mommes, baht, grain, mesghal, Newton, ozt		g, kg, lb, ct, oz, dwt, tical, tola, mommes, baht, grain, mesghal, Newton, ozt		
Platform Size	3.54 in / 9 cm diameter			4.72 in / 12 cm diameter		7.1 in / 18 cm diameter			
Cal Weight-Span	50, 60g	50, 100g	100, 200g	100, 150g	200, 300g	200, 500g	1000, 1500g	2, 3kg	2, 4kg
Cal Weight-Linearity	20 / 50g	50 / 100g	100 / 200g	100 / 150g	150 / 300g	200 / 500g	1000 / 1500g	1.5 / 3kg	2 / 4kg
Taring Time	1 second								
Stabilization Time	3 seconds								
Draftshield	7.3 in / 18.5 cm inside height					None			
Operating Conditions	50° F / 10° C to 104° F / 40° C at 10% to 80% relative humidity, non-condensing, up to 4000m above sea level								
Storage Temperature	-40° F / -40° C to 158° F / 70° C at 10% to 80% relative humidity, non-condensing.								
Gross Weight	10.0 lb / 4.5 kg					7.3 lb / 3.3 kg			
Shipping Weight	15.2 lb / 6.9 kg					11.8 lb / 5.4 kg			
Balance Dimensions W x H x D	7.7 x 11.3 x 12.6 in / 19.6 x 28.7 x 32 cm					7.7 x 3.6 x 12.6 in / 19.6 x 9.2 x 32 cm			
Carton Dimensions L x W x H	19.5 x 15.5 x 20.6 in / 49.5 x 39.5 x 52.2 cm					19.5 x 15.5 x 12.8 in / 49.5 x 39.5 x 32.7 cm			

Outline Dimensions

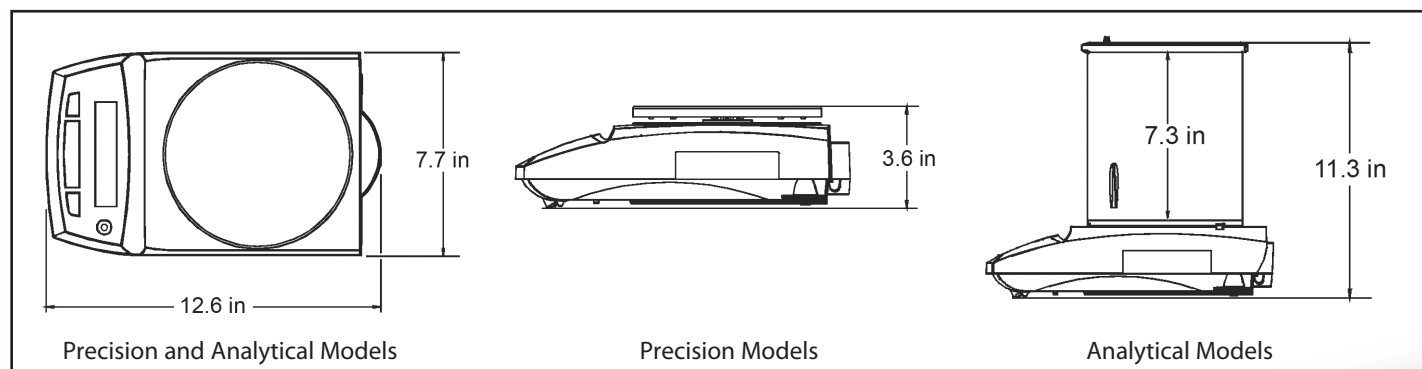

Pioneer[®] Analytical and Precision Balances

Standard Features



Integral Security Bracket

Allows you to secure your balance to a

workstation to prevent unwarranted movement or theft

RS232 Interface

Pioneer's RS232 allows connection to an Ohaus printer or a computer. Sends Balance ID plus spaces for recording User ID, Project ID, time and date

Integral Menu Lock

A combination of software and a mechanical switch locks menus, including calibration



Weigh-Below Hook

Pioneer's built-in weigh-below hook allows you to suspend an item below the



balance to calculate density/specific gravity



Up-Front Level Indicator

A quick glance at the up-front level indicator helps to ensure that the balance is level prior to each use

Multiple Application Modes and Units

Pioneer features basic Weighing, Parts Counting and Percent Weighing, and 15 international weighing units including one custom unit

Other Standard Features and Equipment

AC adapter, user selectable span calibration points, software reset menu, stability indicator, Auto Tare, user selectable communications settings, user selectable printing options, stainless steel platform

Compliance

Safety: FCC (Part 15 Class A), CE (EN 61326 Class A, Criteria A)

C Tick N13123 (AS/NZS4251.1, AS/NZS4252.1)

Accessories

Dot Matrix Printer	80252042
Cable kit to connect Dot Matrix Printer to Pioneer	80252571
Paper for Dot Matrix Printer	80251932
Ink Ribbon for Dot Matrix Printer	80251933
Thermal Printer	80251992
Paper for Thermal Printer	80251931
Cable kit to connect Thermal Printer to Pioneer	80252581
Ohaus Collect Software	80500746
TAL Software WinWedge	SW12W
RS232 Cable, PC 9 Pin to Pioneer	80500525
RS232 Cable, PC 25 Pin to Pioneer	80500524
Auxiliary Display Kit for Pioneer	PAD7
Security Device for Pioneer	76288-01
Density Determination Kit for Pioneer (0.1mg and 1mg)	80253384

Industry Leading Quality and Support

All OHAUS Pioneer balances are manufactured under an ISO 9001:2008 Registered Quality Management System. Our rugged construction and stringent quality control have been hallmarks of all OHAUS products for over a century.

OHAUS CORPORATION

*7 Campus Drive
Suite 310
Parsippany, NJ 07054 USA

Tel: 800.672.7722
973.377.9000
Fax: 973.944.7177

www.ohaus.com

With offices throughout
Europe, Asia, and
Latin America

*ISO 9001:2008
Registered Quality
Management System

