



WORKING PRINCIPLE:

- Flour is transported to sifting case with rifling system and flour is sifted by passing the sifting system which is called silk sifter.
- Sifted flour is transported from the exit case to dough kneading machines as cleaned and sifted.
- Gathers the undesirable substances in its litter bag.

GENERAL FEATURES

- Designed for sifting the flour which is pressed and humid.
- In-feed hopper located at ground level for safe and effortless loading of product.
- Sifted flour is transported from the exit case to dough kneading machine as cleaned and sifted.
- Gathers the undesirable substances in its litter bag.
- Sifts the materials like hair and sand.
- Stainless Steel 304 Q body.
- Silent and without vibration.
- Easy transport by wheels.
- Easy to use.
- Produced according to CE standards.
- One year warranty against defect of manufacturing and assembly.

OPTIONAL : Mono phase (230 VOLT) motor available .

TECHNICAL FEATURES

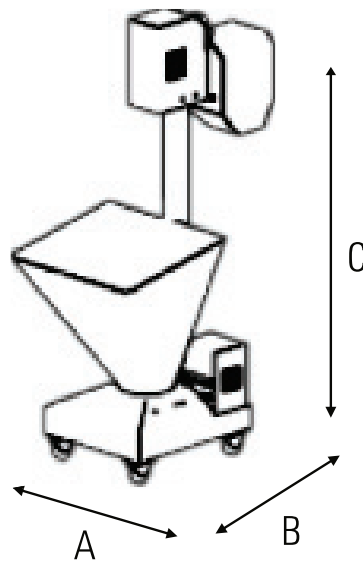

AxBxC (mm)
780x1050x1670

WEIGHT



KG

82 kg

CAPACITY



50 kg

POWER

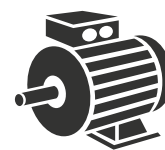

0,92 kw