

# LFNE5B Commercial Washer



## 10 KG COMMERCIAL TOUCH CONTROL FRONT LOAD WASHER

### Features and Benefits

- Low water consumption of only 54.3 litres per wash on a standard cycle with NO options with full wash completed in 30 minutes.
- Energy saving 'High Speed Extract' spin cycle of 1,200 rpm producing 'G' forces in excess of 440 for greater water removal, resulting in reduced drying times and associated energy savings.
- Soft mount machine requires no bolting down to secure.
- Pre-Wash and extra rinse option for heavily soiled loads.

### SPECIFICATIONS

DIMENSIONS	
CAPACITY	10 kg
WIDTH	683 mm
DEPTH	704 mm
HEIGHT	1,027 mm
DRUM VOLUME	96.8 litres
NET WEIGHT	113 kg
OPERATION	
CYCLES	6 Cycles, 3 Soil Levels
CYCLE LIGHTS	Yes & Timer Display
CONTROLS	Commercial E MECH
ACTIVATION	Electronic Touch
WATER TEMP	Hot, warm or cold
MOTOR	1 hp, variable speed
SPIN SPEED	500 - 1,200 rpm, variable speed
WATER USE	44.3 litres / wash standard cycle
FRONT SERVICE	Yes
CONSTRUCTION	
DRUM	Stainless steel
OUTER BOWL	Stainless steel
OUTER CABINET	Steel



# LFNE5B Commercial Washer



## TECHNICAL SPECIFICATIONS

### UTILITIES

10 AMP SINGLE PHASE 240 V 50 HZ

10 AMP CIRCUIT-BREAKER REQUIRED

1.8 M POWER CORD

HOT AND COLD WATER CONNECTIONS REQUIRED

1.2 M HOT AND COLD WATER HOSES SUPPLIED

WATER SUPPLY HOSE TAP **ENDS** 3/4 BSP THREADS

MAX HOT WATER CONSUMPTION 31 LITRES / CYCLE (INC PRE-WASH)

MAX WATER CONSUMPTION 70.6 LITRES / CYCLE

MAX POWER DRAW 750 W / HR

DRAIN: 610 - 914 MM UPSTAND, 50 MM DIAMETER

WATER SUPPLY PRESSURE BETWEEN MAX 820 KPA/MIN 140 KPA

### SHIPPING DIMENSIONS

WEIGHT 122 kg

HEIGHT 1,156 mm

WIDTH 737 mm

DEPTH 832 mm

0.71 m<sup>3</sup>

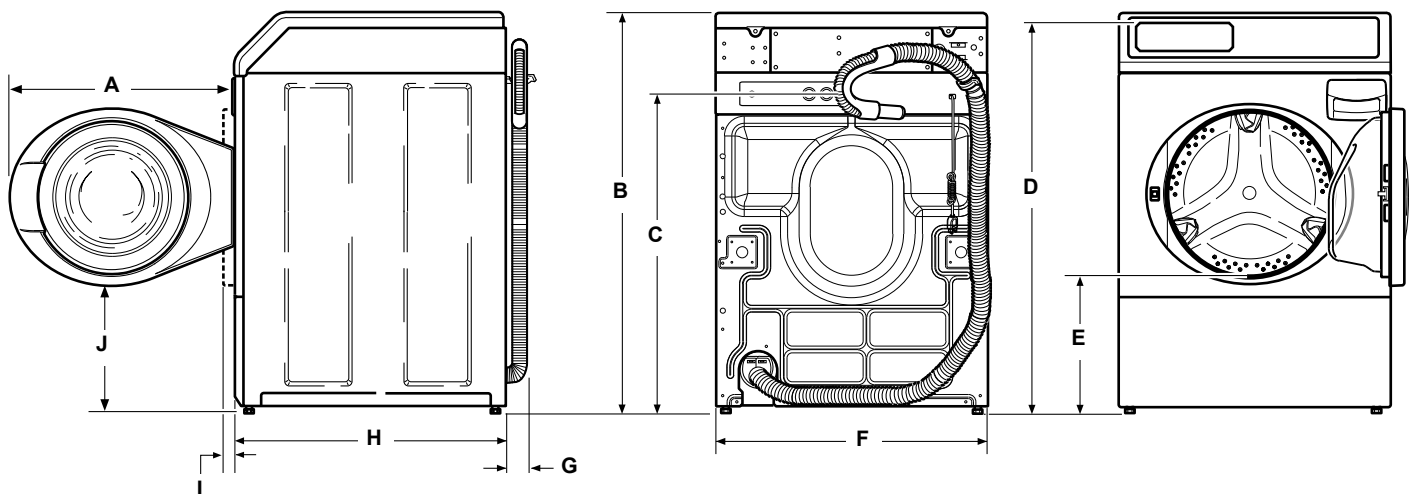

A 611 mm [24.06 in.]  
D 1006 mm [39.61 in.]  
G 52 mm [2.04 in.]  
J 333 mm [13.1 in.]

B 1027 mm [40.42 in.]  
E 371 mm [14.6 in.]  
H 704 mm [27.73 in.]

C 813 mm [32 in.]  
F 683 mm [26.875 in.]  
I (with door closed) 40 mm [1.59 in.]

\*For the most accurate information, the installation guide should be used for all design and construction purposes. Due to continuous product improvements, design and specifications are subject to change without notice.



SPEED QUEEN EQUIPMENT SALES  
26 Theobald Street  
THORNBURY, VIC 3071  
P:03 9495 1300  
E:sales@speedqueensales.com.au