

# WEST-TRANS

## SKIP LOADER

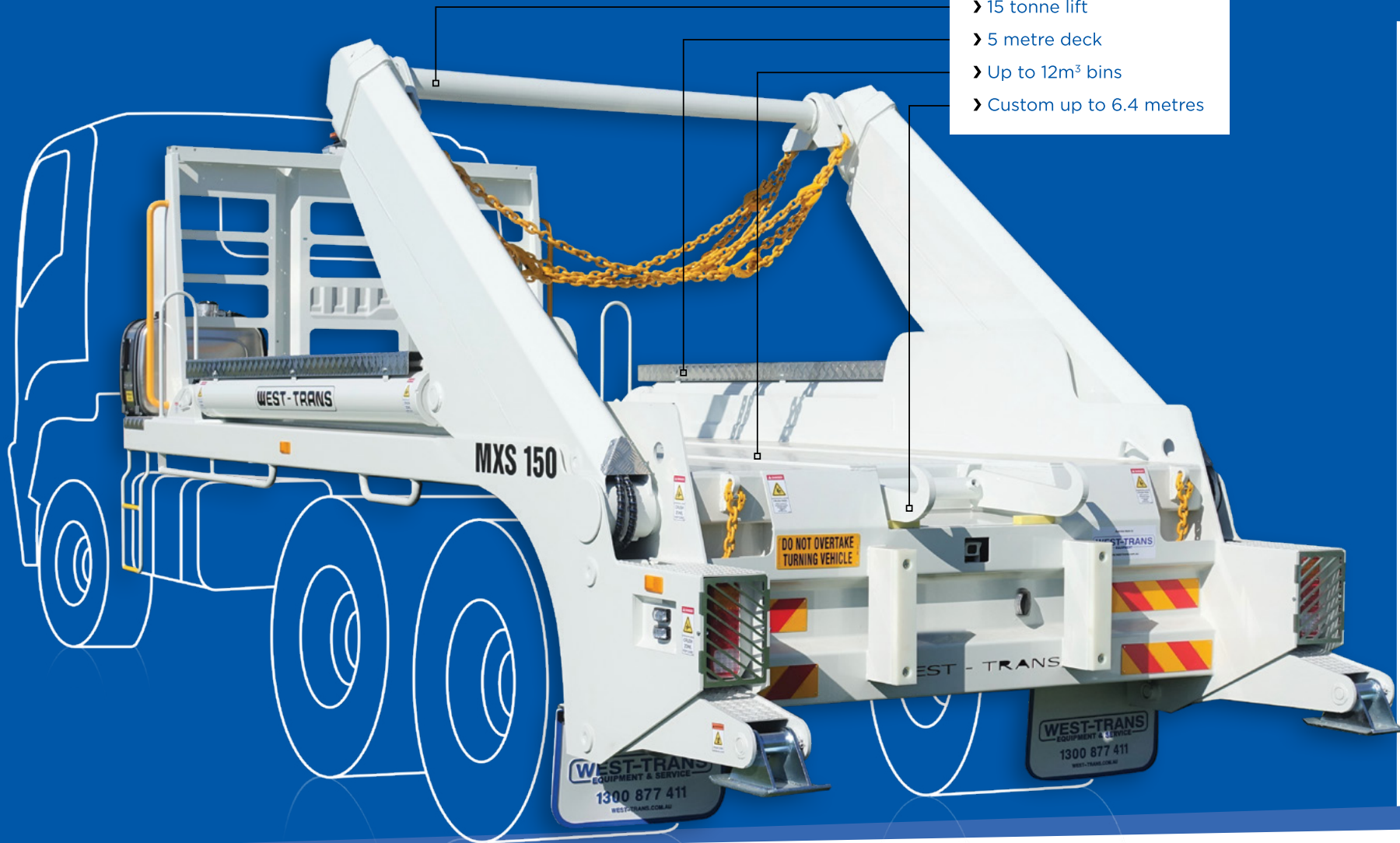

- › 15 tonne lift
- › 5 metre deck
- › Up to 12m<sup>3</sup> bins
- › Custom up to 6.4 metres

# MXS 150

## High Lift Capacity

*The West-Trans MXS 150 is the industry benchmark for hardworking, heavy duty skip loaders. Built tough by craftsman here in Australia, it is the skip loader chosen more than any other for the day in, day out, punishment of the waste and recycling industry.*

All **West-Trans** skip loaders are constructed from high tensile structural steel, and quality components to deliver you the toughness and reliability you need for years of low maintenance trouble free service.

All **West-Trans** skip loaders can be recognised by their low arm fold height, aluminium cylinder protection, clean solid construction, and no fuss durability. Even our biggest loader has a folded and retracted arm height of just 1730mm (top of chassis rail to top of arm), dealing with low clearance bridges, construction spaces, and overhanging trees without trouble.

Being designed and manufactured in Australia, they are, of course, built to meet or exceed all relevant Australia Design Rules, but more importantly, they are built to handle the toughest conditions Australia can throw at them.

All **West-Trans** skip loaders are protected with an anti-corrosion primer base coat, and 2 coats of high gloss colour.

Speak to a **West-Trans** sales professional today, or go to the website [west-trans.com.au](http://west-trans.com.au) for more details.

Call 1300 877 411 or visit [west-trans.com.au](http://west-trans.com.au)

**WEST-TRANS**  
EQUIPMENT

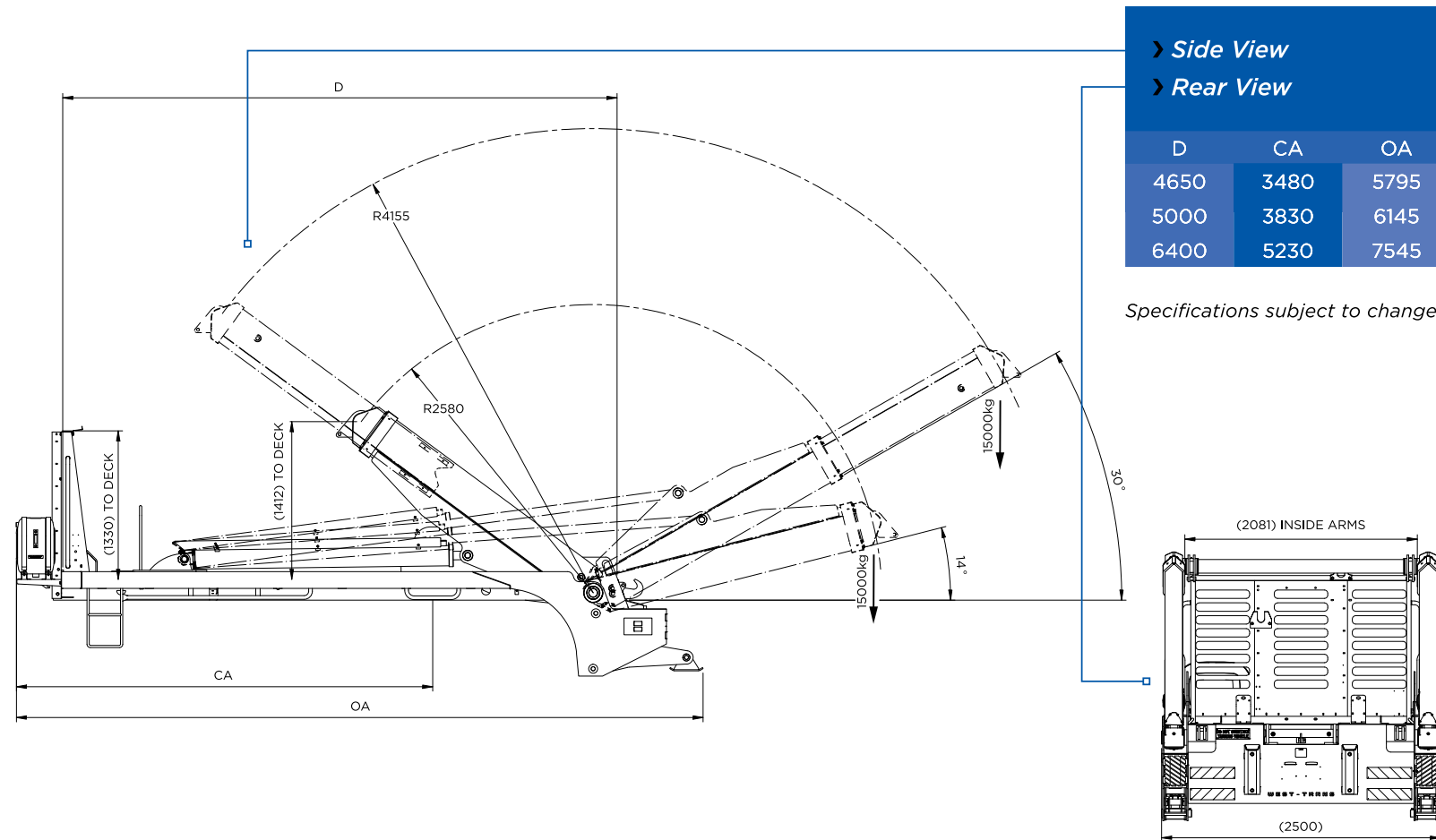

*This popular model is designed around the major truck manufacturer's standard bogey drive chassis in the 24-26000kg GVM, MWB range and with a choice of 3 standard deck lengths available, most fitting without modification.*

Of course, being built in Australia, you can choose a custom build, accommodating tipping hooks or chains, your choice of colour, or the addition of a range of accessories and modifications.

Extended deck options and Ringfeder designs available by special build.

### Recommended Cab Chassis:

- › GVM 24,000-26,000kg
- › 6x4 4400mm wheel base (min cab to axle 3480mm - theoretical)

Choose a **West-Trans** skip loader. **Built tough in Australia.**

### Options:

- › Tipping Hooks or Tipping Chains
- › In Cab Controls
- › Amber Flashing Beacons
- › Tool Boxes
- › Work lights
- › Broom and Shovel Brackets
- › Tarping Systems
- › Special surface coatings