

# specifications

## RF8.PPZ.4.SD

# INDUSTRY KITCHENS

www.industrykitchens.com.au 1800 611 058

# SKOPE

## ReFlex Series, 4 Door (Solid), Large Pizza Preparation Fridge

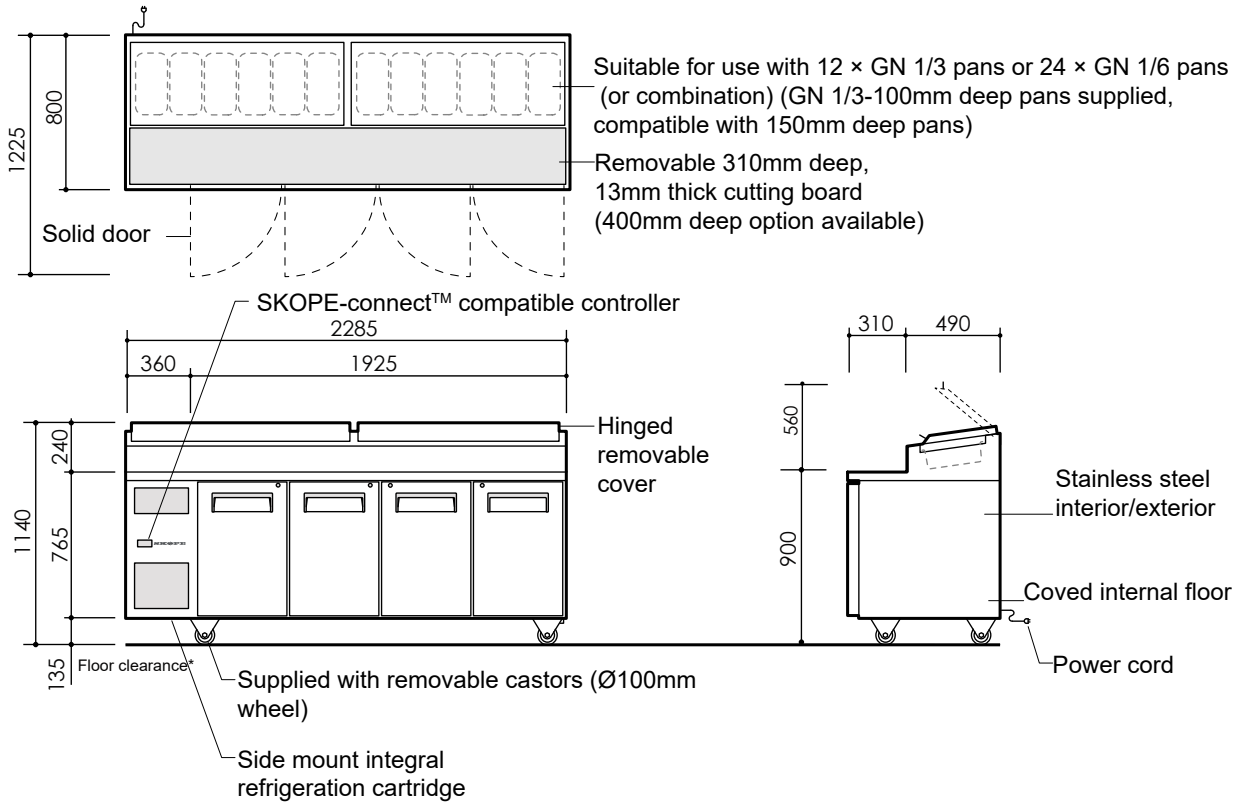

### CABINET

Doors	4 × self-closing, lockable, solid swing door with stay-open position at over 90°, hinged LH, LH, RH, RH.
Internal door opening	4 × door openings: 590mm high × 370mm wide
Shelves	8 × adjustable height shelves: Middle shelves: 475mm wide × 610mm deep. Outside shelves: 415mm wide × 610mm deep. Each shelf is held in place with four shelf clips, and additional shelf clips available on request.
Worktop	Removable, food grade, 13mm plastic cutting board
Material	304 AISI stainless steel interior and exterior

### PERFORMANCE

Max. ambient temp.	40°C (lid(s) closed), or 30°C (lid(s) open)
Temperature range	1°C to 5°C (adjustable with SKOPE-connect 0°C to 15°C)
Total energy consumption	5.83 kWh/24h (@ 30°C/55%RH)
Annual running cost	\$639 p.a. (@ \$0.30/kWh)

### ELECTRICAL

Electrical safety climate class	5 (40°C/40% RH)
Interior lighting	3 × 400mm, 4W LED light (door activated)
Power cord	Supplied with 2.7m, 10 Amp plug and lead
Power supply	220-240 Volts a.c. 50 Hz, single phase supply
Current draw	3.5 Amps (includes unit 2.2 Amps)

### REFRIGERATION

Controller	SCS Connect (SKOPE-connect compatible)
Connectivity interface	Bluetooth® wireless technology
Refrigeration system	Side mounted, integral, removable refrigeration cartridge (part number ULQCN1-0030)
Refrigerant	R290/90g (natural refrigerant)
Nominal capacity	900 Watts
Heat rejection (Avg/peak)	250 Watts/300 Watts
Drainage	No plumbing required

### DIMENSIONS

	External	Internal
Height	1140mm	605mm
Width	2285mm	1835mm
Depth	800mm	640mm
Floor area	1.83m <sup>2</sup>	
Weight	233kg	
Gross volume	710L	

### Height variation

Supplied castors	1140mm
Supplied height adjustable legs	n.a.
No castors	1005mm

### Dimensional tolerances

Before installing this cabinet allow the following dimensional tolerances:

Linear dimensions	Cabinet overall dimensions	
Less than 1 metre	±5mm	
More than 1 metre	-5mm to +10mm	
	Length of multiple cabinets	
	At each joint	At each end
Less than 1 metre	±5mm	+15mm
More than 1 metre	-5mm to +10mm	+15mm

### Ventilation requirements

Top	Not required
Sides	Not required
Back	Not required
Bottom	Not required

SKOPE Industries Limited reserve the right to alter specifications without notice. Copyright © 2020

### SKOPE INDUSTRIES LIMITED

Australian Freephone: 1800 121 535, New Zealand Freephone: 0800 947 5673  
Email: skope@skope.com, Website: www.skope.com

PSS0669 Rev. 1.4 Mar. 2021

