

## Drum Lifter / Rotator & Pourer- 450kg Capacity Lifts Steel, Plastic & Fiber Drums

The MTBFL is ideal for applications where drum or barrels are stacked, transported, and poured. This barrel lifter is ideal for liquid transportation of oil, chemical, fuel & food allowing the user to be able to pour them without manual labour required.

### Features

- Stacking, transporting, and pouring at an angle made easy.
- Simply wheel the lifter up to the barrel/drum and secure with the gripping device.
- The 180-degree tipping function allows the operator to remain at the controls during the tipping operation.
- Powder coated safety yellow for hi visibility and extra protection from wear and tear.
- The barrel is controlled by the turning wheel.
- Contains a foot pump, hand pump, and foot release pedal for lowering.
- Has a foot brake.



### Specifications

Model		MTBFL
Capacity	(kg)	450
Lift Height	(mm)	1500
Acceptable Drum	(type)	Steel, plastic, fiber
Load Roller Size	(mm)	Ø150x50
Steering Wheel Size	(mm)	Ø150x50
Leg Length	(mm)	770
Distance Between Inner Legs	(mm)	630
Distance between Outer Legs	(mm)	810
Overall Size LxWxH	(mm)	1400x1000x2100
Weight	(kg)	185

Visit [www.mitaco.com.au](http://www.mitaco.com.au) for more photos and details

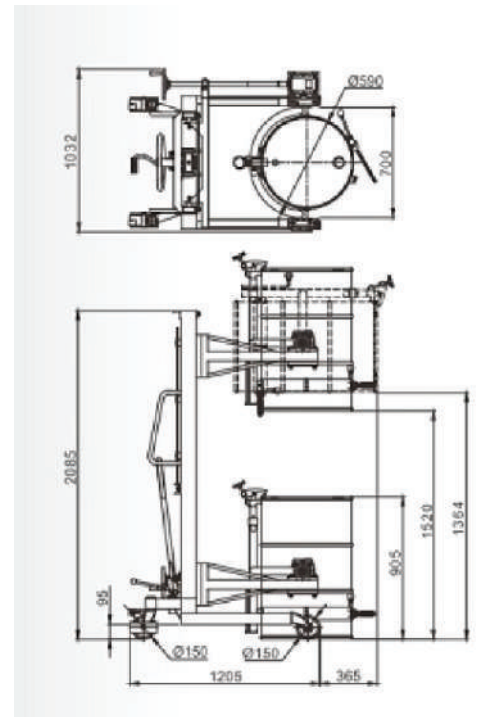

Mitaco has national sales and distribution capabilities, our sales office and warehouse is located in Brisbane. Large inventory holdings enable fast-track dispatch of stock orders. This combined with an easy to use online ordering system makes the delivery of stocked products simple, fast and reliable.