

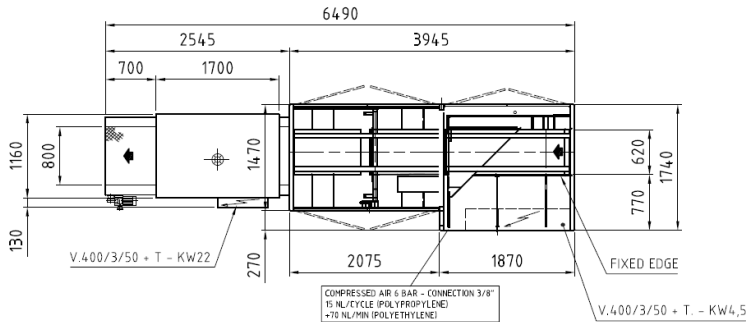

LAYOUT

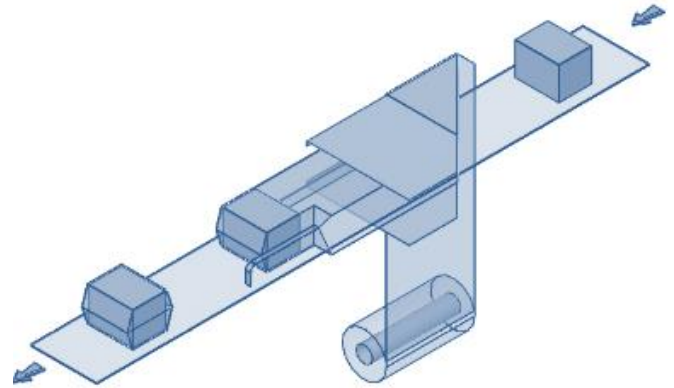

PRODUCT FLOW



SELECTION OF PACKAGING VARIATIONS

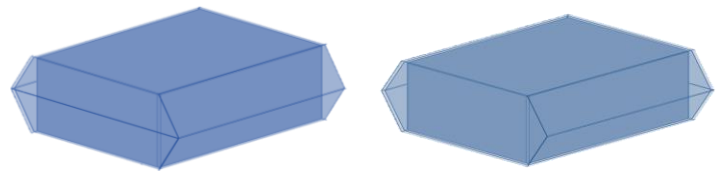

DESCRIPTION

This is an automatic wrapping machine with a continuous side sealing system for packing a large variety of medium industrial products both with P.E or P.P. film. It can pack shrunk packs if combined with a shrink tunnel 80-40,

OTHER TECHNICAL SPECIFICATIONS

Wrapping material	Polypropylene (P.P.) of 11-25 μ pre-perforated film C-Folded film reel
	Polyethylene (P.E.) of 26-60 μ pre-perforated film C-Folded film reel
Final packaging result	Fully closed pack with a lateral lengthwise welding, two horizontal front/back weldings (shrink-wrapped / optional)

TECHNICAL SPECIFICATIONS

Product Dimensions		Min	Max
Width	mm	80	600
Length		150	6000
Height		30	370
Mechanical Speed	Up to 30 packs/min		

MATCHABLE UNITS/OPTIONALS

Pack format	<input type="checkbox"/>	Printed film registration unit	<input type="checkbox"/>
Film reel end pre-alarm	<input type="checkbox"/>	Optical barrier for small products	<input type="checkbox"/>
Extra weight acceptable (25 Kg per meter linear)	<input type="checkbox"/>	Configuration for PP film reels	<input type="checkbox"/>
Remote connection module	<input type="checkbox"/>		