



AutoLift AL-9500HD

2 Post Electric Hydraulic Vehicle Hoist
4500 Kg Lifting Capacity
Extra Heavy Duty Clearfloor Design
For Mechanical Workshop Use

Features

- Clear floor design for ease of working with transmission or under lift jacks, oil drainers or tool chests
- High quality powder coated finish
- Professional quality power unit
- Safety shut off valve
- Long arm two stage telescopic
- Short arm three stage telescopic
- Two stage screw adjustable pads
- Rubber door protectors
- Hydraulic cylinder covers
- Easy operation manual lock release
- Top limit switch cut-off
- 4 x 60mm height adaptors & 4WD extension pads included

Bonus Inclusions:



One sided lock release for single sided operation

Optional Extras:

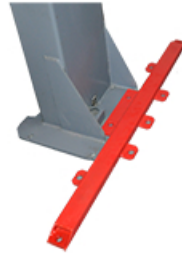

Base Frame for concrete floor



Screw adjustable pads with 4WD & Light Commercial Extension Pads

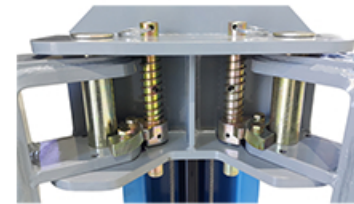

Automatic arm locks

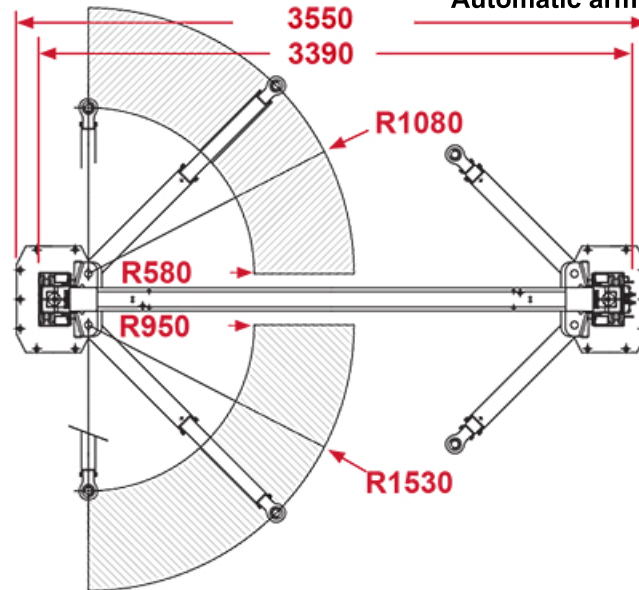
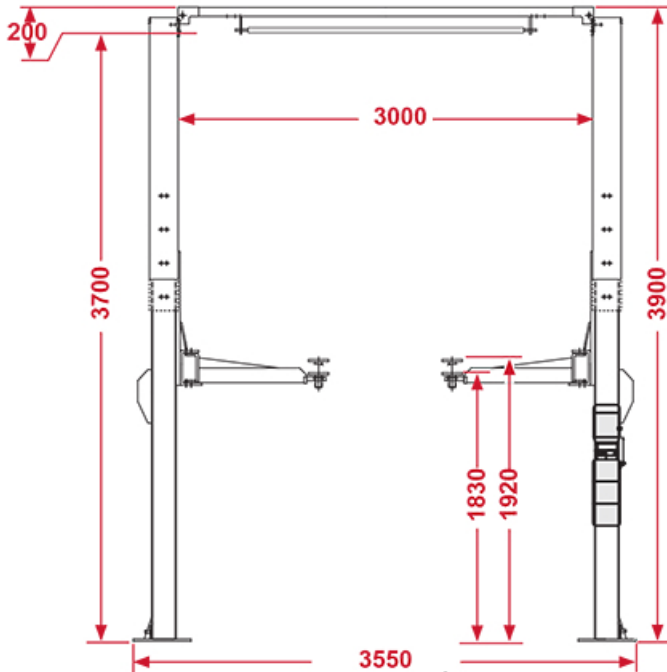

Specification

- WorkSafe Design Registered
- Height overall: 3900 mm or 3750mm for lower height setting
- Width overall: 3550 mm
- Lifting height: 1830~1920mm
- Lowest height: 115~175mm
- Lifting capacity: 4500 kg
- Power: 240V/50Hz/1Ph (15 Amp) or 415V/50Hz/3Ph (20 Amp)
- Gross weight: 830 kg
- Packing Size: 2850*940*450 mm