

Blister line

eBL350

Best performance.
Best value.

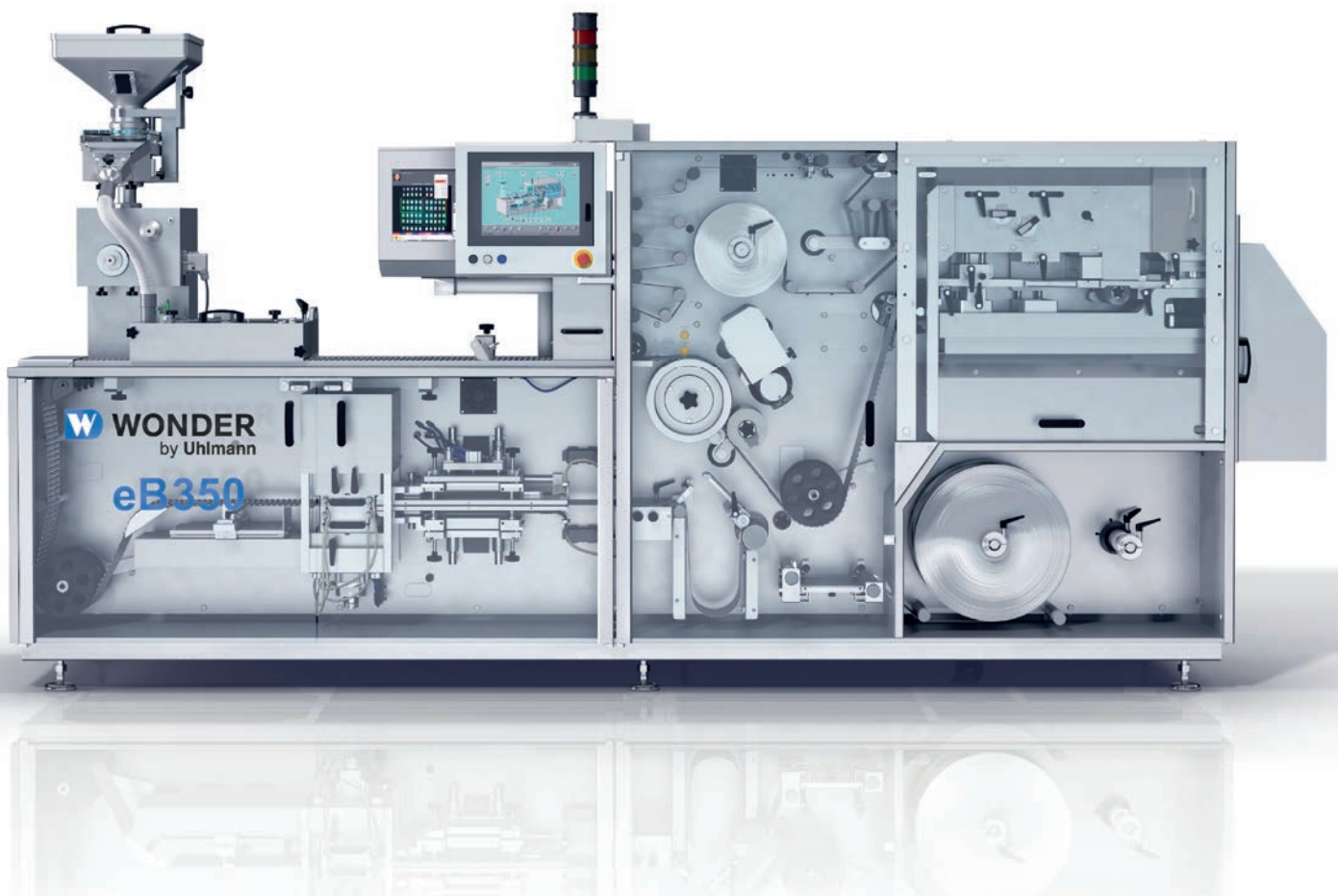

Blister machine eB350

Best performance and best value: With the new blister machine eB350 you can package with the greatest flexibility, security, and efficiency. Whatever the market demands – the answer is right here, the all new eB350. Furthermore, the eB350 is also configurable with compatible cartoner solutions.

New machine, new concept: The eB350 is the result of our worldwide enterprise network: German engineering combined with efficient project management based in Singapore and economical production conditions in China.

Uhlmann Singapore & your local Uhlmann partner are the reliable lifelong partner for all your needs. From the first phone call to acceptance test, we provide ongoing support. Format parts and spare parts are also supplied at a short notice.

The new eB350. Excellence comes as standard. Bringing together over 66 years of experience in the pharmaceutical industry. Discover now why the eB350 combines “best performance” and “best value” successfully.

Highlights

- GMP-compliant cantilever design for easy cleaning in compliance with pharmaceutical requirements
- German engineering for a high quality design guaranteed
- Suitable for thermoforming and cold-forming foils
- Servo technology and easy handling allow quick format changeover
- Easy, intuitive operating system with central touch screen panel
- Up to 350 blisters/min in line or up to 450 blisters stand-alone
- Flexible line configuration with compatible cartoner solutions

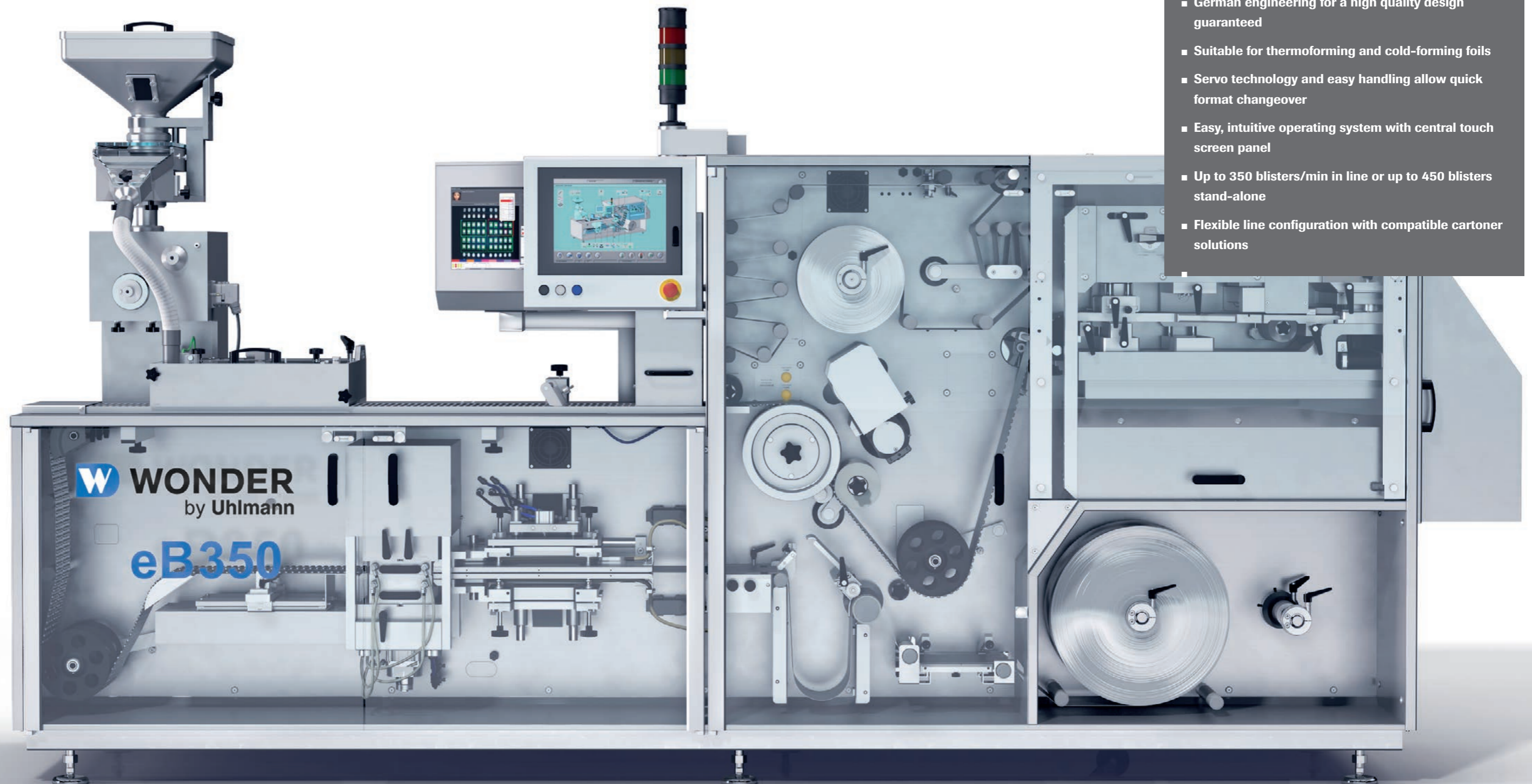

Details

Feeding system

A selection of highly efficient feeding systems is available to process the diverse spectrum of pharmaceutical products. Systems that have been field proven thousands of times. Each system is customized for individual geometries, thickness, coatings and speed requirements.



Central operation with touch screen panel

Central operation via modern touch screen panel. Operator can simply control all machine functions via the panel. Adjustments can be managed easily. Thanks to the self-explanatory user interface, machine can be operated even by less experienced personnel.



Embossing, perforating and punching station

The station for embossing, perforating and punching forms a compact unit driven by a servomotor. Depending on the blister requirement the operator can change the format parts very quickly. Of course all setting parameters can be managed from control side. Blisters are punched out with a low waste. The waste can be collected without machine stops. The guide plate provides an optimum guidance of the web.



Forming station

Four guide columns in the forming station ensure a uniform forming pressure across the output range. Reliable and tool-free clamping system of format parts – easy to handle for quick changeover.

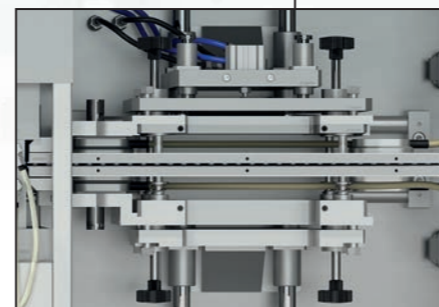
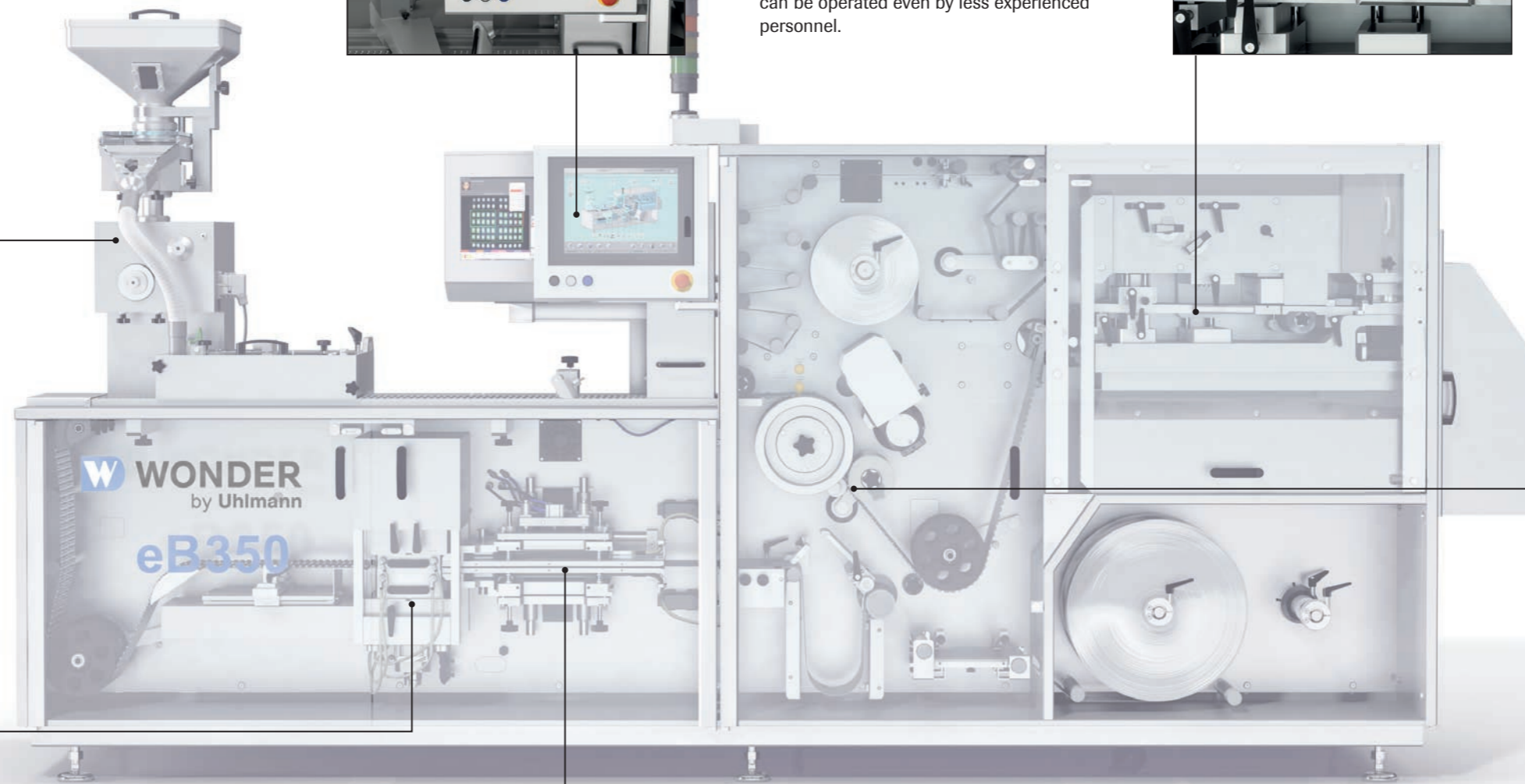

Heating station

A format-free heating station gently heats the forming material. The temperature is fully adjustable with two separate heating zones. Should the machine be stopped, the heating plates automatically open to avoid damage to the web material and product thus ensuring a trouble-free restart.



Sealing station

The servo-regulated roller sealing ensures an excellent sealing result. Various foil types and products are capable of being processed such as tablets (with or without coating), liquid-gels, or capsules. The index roller is easily accessible and can be removed quickly during format changeover.

Technical data

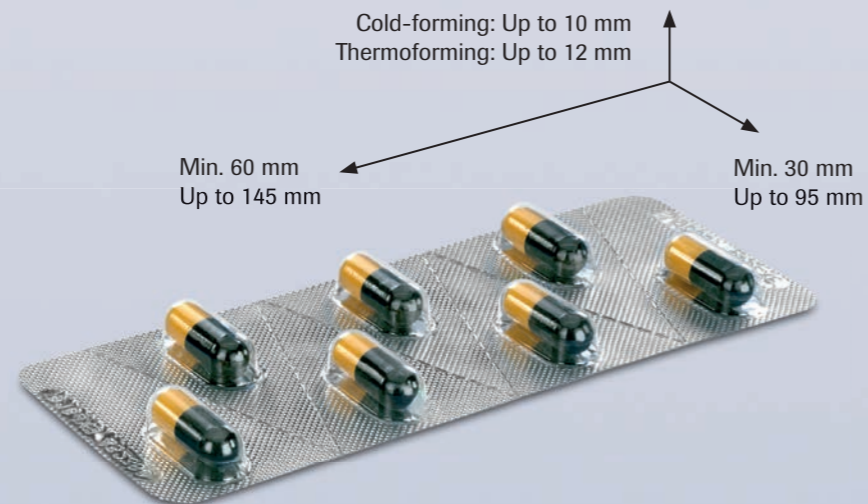

Parameter	Value	
Blister output	Solo blister machine	Up to 450 bl/min
	Inline (three lanes)	Up to 400 bl/min
	Inline (two lanes)	Up to 350 bl/min
Format range (L x W)	Min. 30 x 60 mm Up to 95 x 145 mm	
Forming cycles	Up to 50 times per minute	
Forming depth	Cold-forming	Up to 10 mm
	Thermoforming	Up to 12 mm
Forming film width	Up to 270 mm	
Diameter of forming material reel	Up to 500 mm	
Diameter of lid foil reel	Up to 300 mm	
Processable forming materials	PVC, PVC/PVDC, PVC/Aclar, Aluminium laminates	
Size (L x W x H)	4.154 x 1.194 x 2.137 mm	



Line competence from a single source

A solution for every application! Our experts ensure reliable integration of the cartoner to the blister machine. According to your requirements, you will get a suitable installation solution.

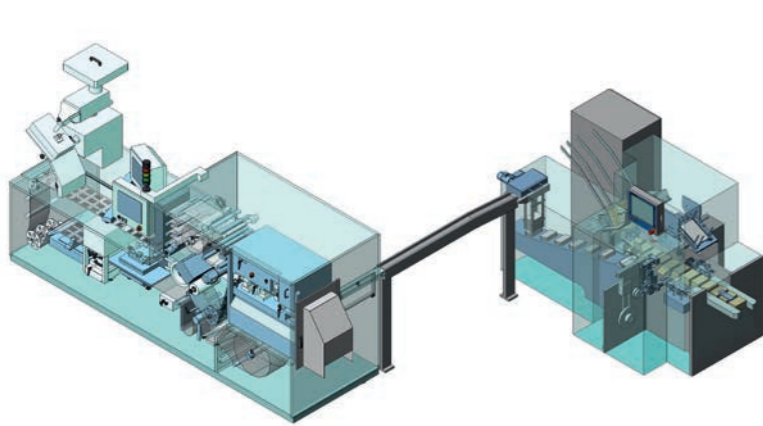

Assembly "Z"

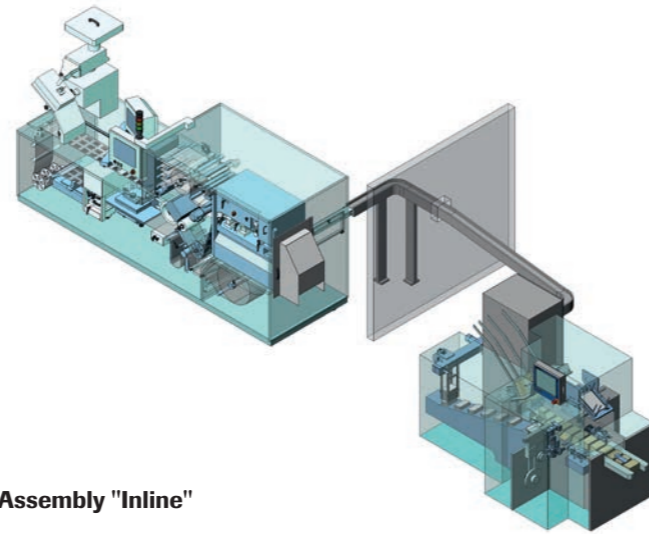

Assembly "Inline"

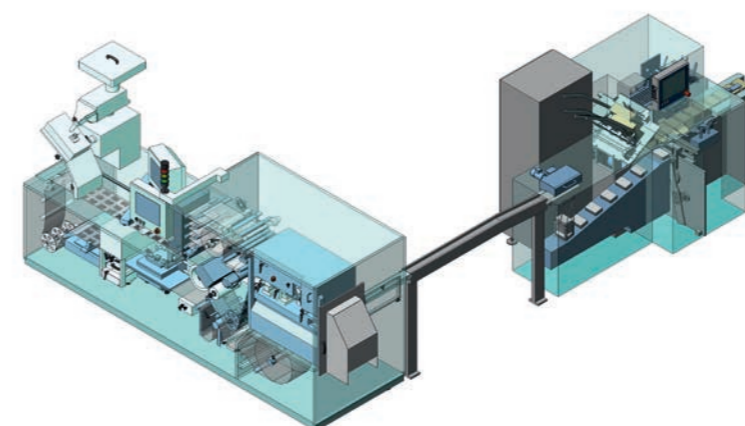

Assembly "L"

Highlights

- Detailed design and execution of line concepts
- Integration of non-Uhlmann components and machines into the packaging line
- Assistance and flexibility regarding bespoke user requirements
- Conducting project management
- Turnkey service – products and support services from a single source

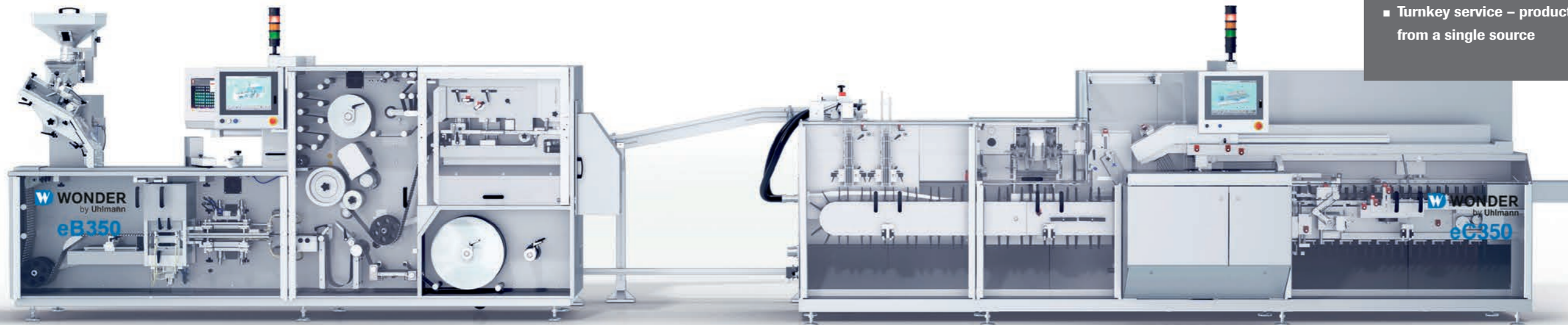

The new cartoner eC350 can be ordered in the 2nd quarter 2016.

Uhlmann Singapore – customer support and service philosophy

Proven quality



Uhlmann Singapore is an established partner in the pharmaceutical market. For over 13 years now, we have been providing “best in class” support to our customers. From our manufacturing facilities to our fully integrated services such as project management and after sales support – you can be sure we will support your investment.

Singapore has a team of competent engineers who are well-trained and experienced. With a skilled and multicultural workforce using English as the official language, we are focused on the customer.

Worldwide service



No matter where in the world you are based, we can support you on site and on time. When it comes to the crunch time, our service engineers are right there with you. They are dedicated to support you with their excellent competence and willingness to help. They will keep machine downtime to a minimum and ensure highly efficiency production runtime.

Tools and spare parts



Our spare parts, tooling and format parts stand for high quality and reliability. The same goes for our machines. We deliver only products with a long service life span and productivity.

All tools are designed, planned, and manufactured by us including a permanent archiving of all data and drawings. The acceptance test will be done by an experienced expert in our company. The same expert is also responsible for the controlling and recording of all data to ensure safe and successful commissioning on site.

Sales & Services at its best

- Comprehensive advice from experienced sales personnel and project managers for the project planning of new machines and lines
- Support in the integration of additional machines into the complete packaging line
- Development of the appropriate blister design
- Professional servicing and maintenance by a local team of competent support service technicians





Uhlmann Singapore LLP
107 Eunos Avenue 3 #01-01
Singapore 409837
Phone: +65 65925938
info@uhlmann-singapore.com