



Tug Axis 4T

Operating Manual

Tug Axis 4T Operating Manual – OM0026E/1

Issue date: 19/12/2024

This manual contains important safety, installation and operating instructions for this unit. Read this manual thoroughly and completely, and retain for future reference. This unit can cause serious injury to personnel or damage to property if used incorrectly, therefore do not use this machine for any other purpose apart from its intended use. Using this unit incorrectly may void warranty.

Any damage audible or visible to this unit should be addressed at the time of discovery. Electrodrive Pty Ltd can provide parts and service support on request through its service partner company:

Serviced Equipment Pty Ltd

p: 1300 934 471

e: service@fallshaw.com.au

Made in Australia by:

Electrodrive Pty Ltd

2A Ayton Street, Sunshine North VIC Australia 3020

p: 1300 934 471 (within Australia)

p: +61 (03) 9300 8555 (International)

e: sales@electrodrive.com.au

w: www.electrodrive.com.au

© Electrodrive

Contents

Introduction.....	5
Features	5
Controls	6
Operating instructions	6
Controls	7
Driving instructions	9
Safety check.....	9
Hitching to a trolley.....	9
Unhitching.....	10
Steering.....	11
Charging	11
Maintenance	12
Batteries.....	12
Tyres.....	12
Motor and transmission.....	12
Brakes.....	12
Motor controller	12
Throttle lever	12
Fuses	13
Self-resetting circuit breaker.....	13
Warranty	14
Modifications and misuse will void your warranty.....	14
General wear items not covered under warranty.....	14

Appendix 1: Machine rating conditions	15
Appendix 2: Wiring diagram	16
Appendix 3: Fault codes	18
Appendix 4: Charging procedures for SLA batteries	19
Charging setup	19
During charging	19
Charger manual	19
Appendix 5: Spare parts list	20
Service log	22

Introduction

Effortlessly move trolleys or wheeled equipment using the battery powered Tug Axis 4T.

The Tug Axis 4T enables a single user to easily move up to four tonne load capacities. It simply hooks on to your existing trolley or wheeled equipment with a simple hitch. Productivity is greatly increased, and back or shoulder strain is eliminated.

Suitable for use:

- Through long corridors, factory aisles, round tight corners.
- Up and down ramps.
- On and off lifts.

Features

- Rated to tow up to 4000 kg.
- 24 Volt DC power.
- Variable speed drive unit.
- Electro-magnetic park brake.
- Travel speed—up to 4 km/h.
- Robust steel chassis.
- Tiller handle steering that folds up to reduce space when not in use.
- Programmable motor controller.
- Automatic charger.

Operating instructions

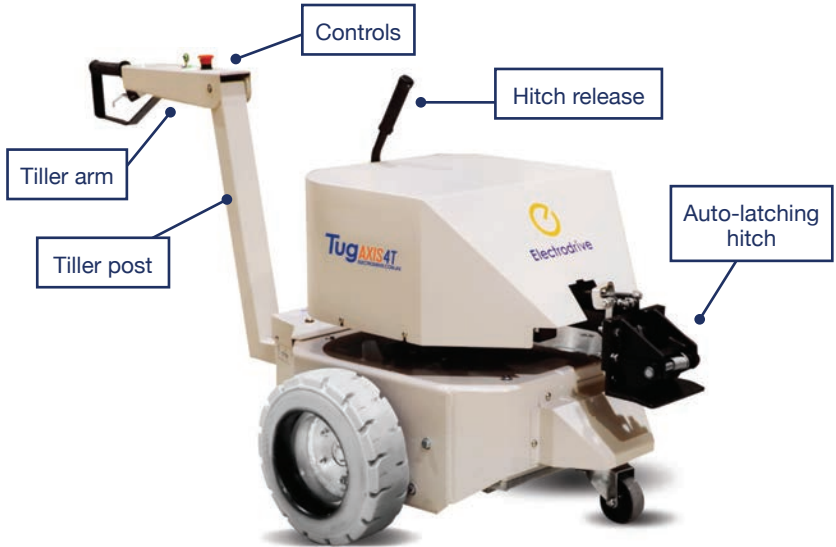

Controls

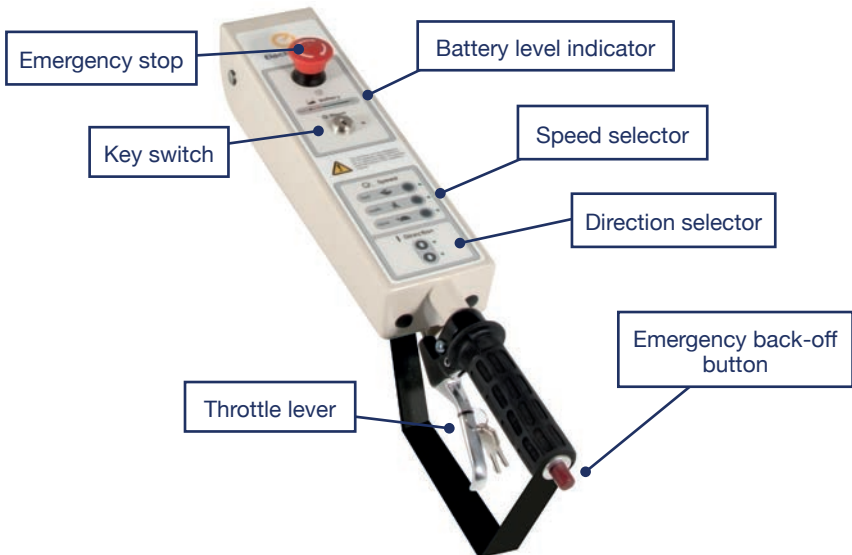

Controls

Key switch

The key switch must be turned clockwise to switch the unit on. When ON, the LED status indicator will be illuminated. If a fault occurs with the electronics, this LED light will flash an error code (refer to Appendix 2). It is important to note that the unit should be switched off and the key removed, whenever it is not in use. This eliminates the risk of unauthorised movement and also prevents an unnecessary use of battery power.

Emergency stop and back-off button

The controls have two emergency buttons.

1. Emergency stop button—in an emergency, push this button to stop the unit. To release, slightly twist the button and it will pop back up.
2. Emergency back-off button—when pressed, the unit will travel backwards until released, to avoid pinning the operator against an obstacle.



Only use the emergency buttons in an emergency.

Direction selector

This determines the direction of travel. Push the button corresponding to the desired travel direction (forward/reverse).

Throttle lever

This lever provides variable speed control from zero up to 100% of the governed speed. Releasing the lever stops the unit.



Speed selector

The speed selector will always start in the SLOW position. Select a speed that you are comfortable using. The speed can be changed whilst driving. It is advisable that you operate this unit at a slow speed when entering a confined area.

Battery level indicator

The battery level indicator indicates the amount of charge left in the batteries. When it appears to be running low, return the unit to the closest charging station to charge the batteries. Being aware of the level of charge of the batteries will eliminate the possibility of running low on power whilst away from the charging station. Red light only indicates no usable battery power remaining.

Horn (where fitted)

Push to sound the horn, release to turn off.

Charger socket

The charger socket is located on the body panel of the unit, next to the tiller post.

Brakes

When the speed control lever is released, the unit is slowed electrically by dynamic braking until the machine and load comes to a complete stop.

Capacity

Refer to the serial plate for the unit's safe working load, located on the body adjacent to the tiller post.

Driving instructions

Safety check

Before using the powered tug, the operator should complete the following check:

1. The battery charger is not connected.
2. The direction selector works.
3. The emergency stop button is released.
4. The brakes operate correctly when the throttle lever is released.
5. The battery indicator shows adequate charge.
6. There is no visible damage to the unit.
7. Back-off button works correctly.

Hitching to a trolley

This tug is fitted with an auto-latching hitch. Other hitches are also available.

1. Facing the tug, unhook the hitch release handle and move it backward. This unlocks the auto-latching hitch.

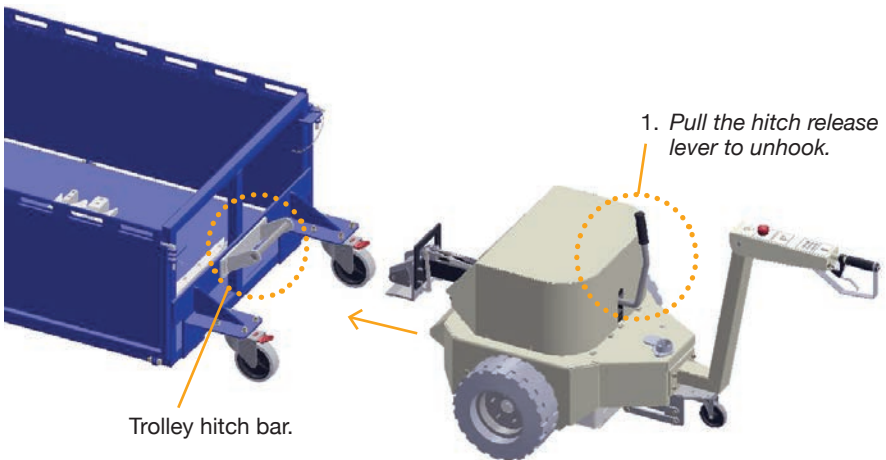

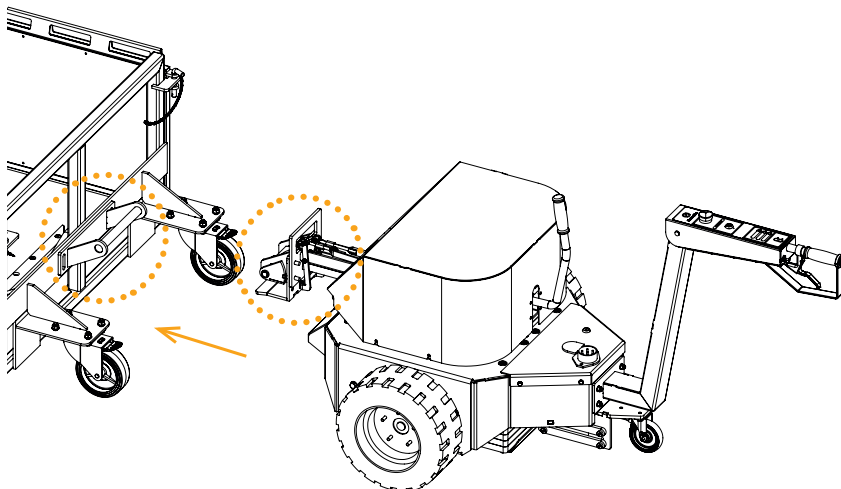

2. Carefully reverse the tug back onto the trolley's tow bar until the tug hitch sits over the tow bar.
3. Once aligned, move the tug forward. This will automatically lock the tug hitch over the trolley's tow bar.

In all cases, ensure that the trolley being attached to has its brakes engaged (or chocked) and is free from obstruction. Inspect the trolley and ensure that the trolley castors are in good condition.

Unhitching

Always make sure the trolley is on a flat level surface and apply the castor brakes (if fitted) or chock the trolley wheels.

1. Unhook the hitch release handle by pulling towards operator to unlock the hitch.
2. Carefully drive the tug forward away from the trolley.



Towing a trolley with castors in poor condition can overload the tug, and cause damage not covered under warranty.



This tug is not intended for use on surfaces with a gradient steeper than 1:8. Operating it on such inclines may increase the risk of accidents or injury and will void the warranty.

Steering

The tiller arm provides easy steering. The tug with an attached trolley can be manoeuvred through tight areas.



It is STRONGLY RECOMMENDED that the operator lead the tug and trolley, rather than using the tug to “push” the trolley. This will ensure that the operator has a safe unobstructed view ahead. This will also make the tug and trolley easy to manoeuvre.



This unit’s power transmission system is a transaxle arrangement.

Obstruction or resistance to one wheel will cause driving power to be transmitted through to the wheel that is free. This may cause the tug to spin out of control. Please ensure a clear and clean path ahead when operating the tug.

Charging

Ensure regular recharging of batteries (charging overnight after a day’s usage is recommended). Irregular charging may cause the batteries to prematurely fail.

Leaving a machine in storage without charge for periods greater than a month can also lead to premature battery failure. This is not covered under warranty.

For detailed charging procedures refer to *Appendix 4: Charging procedures for SLA batteries*. Misuse of the battery will void warranty.



Only use the battery charger supplied with this tug.

The automatic features of the supplied charger ensures that the sealed gel batteries are not overcharged, and only a minimum amount of gas, if any at all, are expelled during charging.

Maintenance

Batteries

If this unit is not being used for an extended period of time, it should be connected to the battery charger to check the battery level on a regular basis, and placed on charge overnight if required. This will ensure the batteries are kept in good condition.

The batteries are sealed and maintenance free. DO NOT attempt to open these batteries. If the unit is not charged as above, the batteries may be exhausted and have dropped below the charging threshold of the battery charger. The supplied charger cannot begin to charge the batteries unless they have a small amount of charge. If this occurs, contact Electrodrive or your local service agent.

A sign that the batteries need replacing is when they no longer hold charge.

Tyres

The tyres are solid rubber and do not require maintenance. For replacement tyres, please contact an authorised Electrodrive technician.

Motor and transmission

The motor and transmission should only be serviced by an authorised Electrodrive technician.

Brakes

The dynamic braking system does not require regular maintenance.

Motor controller

This unit is not serviceable. Any difficulties experienced with speed control should be referred to Electrodrive.

Throttle lever

The throttle lever and cable do not require maintenance. Should the lever or cable suffer damage they should be replaced. If the handle loosens with wear, the hinge nut can be gently tightened. However, first confirm that the lever is in the correct position as it may need to be reset. (Test by squeezing the lever slightly. The tug should slowly move, release and the tug should completely stop).

Fuses

The control circuit is protected against inadvertent current over-loads. This fuse is located adjacent to the controller under the top cover.

Self-resetting circuit breaker

This tug is fitted with a self resetting circuit breaker in case of momentary over-load. This circuit breaker can be found beneath the top cover on the main electrical control panel. If the unit repeatedly over-loads, test the machine, as the motor may be damaged, and continued use could damage the unit further.

Warranty

Electrodrive Pty Ltd warrants that this product is free from defects in materials and workmanship for a period of twelve months from the date of dispatch from the Electrodrive plant.

If a defect is reported, Electrodrive will repair or replace the defective part, at its own discretion. This warranty does not apply if this unit has been misused, damaged, or modified in any way.

Modifications and misuse will void your warranty

The following activities (including, but not limited to) are examples:

Modifications

- The machine is re-wired by an unauthorised service agent.
- The motor controller is re-programmed by an unauthorised service agent.
- There are modifications to the body or frame of the machine.
- Use of non-specified parts.
- The machine is serviced by an unauthorised service agent.

Misuse

- Shunting loads at speeds in excess of 2 km/h.
- Overloading the unit either during towing or lifting.
- Carrying people or other foreign objects.
- Exposed to rain or other precipitation, unless weatherproof option is installed.
- Using the emergency back-off system to change direction regularly.
- Exposed to a corrosive environment.
- Driven off road—potholes, gravel, etc.
- Driven on slopes with a steeper gradient than 1:8.
- Not being charged adequately.
- Using the emergency stop button as an ON/OFF button.

General wear items not covered under warranty

- Tyres, tubes and castors.
- Drive wheels and motor brushes.
- Hand grips.

Appendix 1: Machine rating conditions

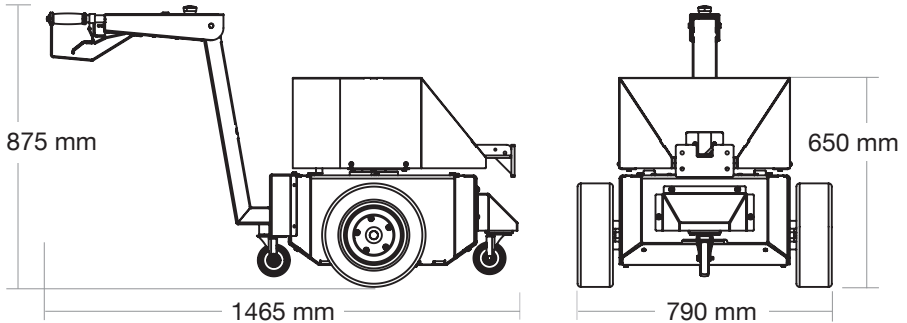

Model	Safe Working Load	Max Load
TUGAXIS4TNH	4000 kg	4000 kg

The Tug Axis 4T has been designed to move the rated weight capacity on a level firm surface. Variations in the working environment may impede the performance of this unit. Such parameters include (but are not limited to) the following:

- Ramps and sloped surfaces.
- Soft surfaces (for example carpet).
- Slippery surfaces (gravel, water, oil on the ground, etc).



It is important that the Tug Axis 4T IS NOT to be operated outside of the recommended conditions.

Appendix 2: Wiring diagram

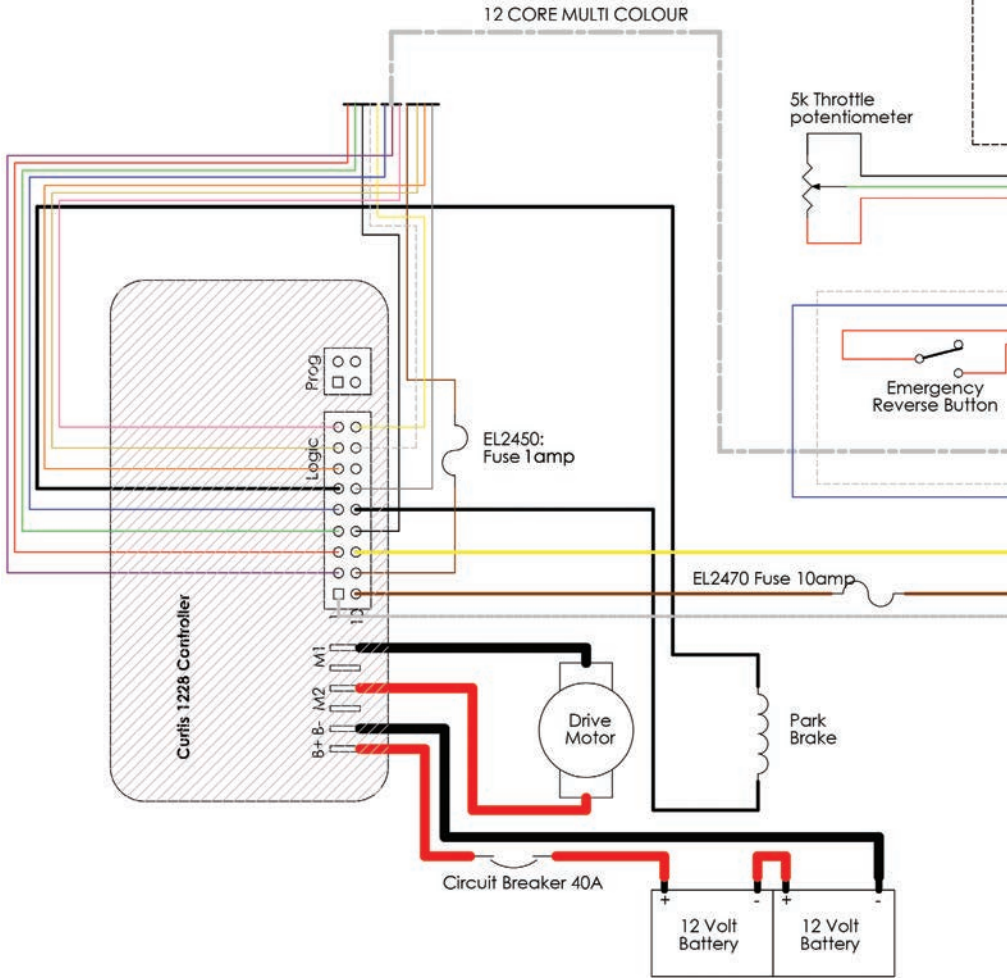

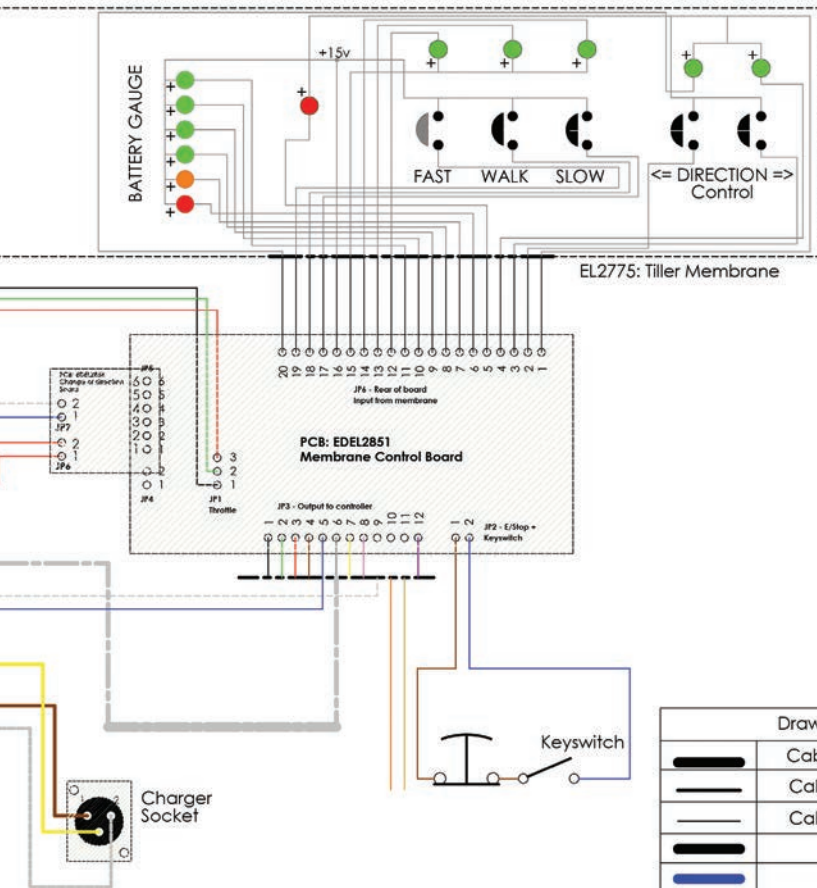

Drawing Key	
	Cable 192/0.22 6mm ²
	Cable 14/2 1.13mm ²
	Cable 7/0.2 0.22mm ²
	Black
	Blue
	Brown
	Green
	Grey
	Orange
	Pink
	Purple
	Red
	Tan
	White
	Yellow

Appendix 3: Fault codes

Fault Code	Explanation	Causes
⊗ ⊗	Over-temperature cutback	Machine overloaded Park brake not releasing properly Short in motor or wiring High ambient temperature
⊗ ⊗⊗	Throttle pot fault	Throttle pot wires open or shorted Faulty throttle pot
⊗ ⊗⊗⊗	Speed governor fault	Speed governor wires open or shorted Faulty speed governor pot
⊗ ⊗⊗⊗⊗	Battery voltage too low	Battery voltage < 17V
⊗ ⊗⊗⊗⊗⊗	Battery voltage too high	Battery voltage > 36V
⊗⊗ ⊗	Main contactor controller failure	
⊗⊗ ⊗⊗	Contactor driver fault	
⊗⊗⊗ ⊗	HPD present > 10 seconds	Throttle out of adjustment
⊗⊗⊗ ⊗⊗	Park brake fault	Park brake coil open circuited Controller failure
⊗⊗⊗ ⊗⊗⊗	Pre-charge fault	Low battery voltage Controller failure
⊗⊗⊗ ⊗⊗⊗⊗	Park brake fault	Park brake coil shorted Controller failure
⊗⊗⊗ ⊗⊗⊗⊗⊗	High pedal disable (HPD)	Throttle not in neutral when key switch turned on
⊗⊗⊗⊗ ⊗	Current sense fault	Short in motor or wiring Controller failure
⊗⊗⊗⊗ ⊗⊗	Motor voltage fault	Short in motor or wiring Controller failure
⊗⊗⊗⊗ ⊗⊗⊗	EEPROM fault	Controller failure
⊗⊗⊗⊗ ⊗⊗⊗⊗	Output section fault	Short in motor or wiring Controller failure

Appendix 4: Charging procedures for SLA batteries

- Always charge batteries when work is complete and the equipment is not required for use.
- Opportunity charging is NOT recommended. This can also shorten battery life.
- Never leave batteries in a discharged state as this will shorten the batteries life.
- For maximum battery life, a battery must be recharged to 100% capacity. Recharging less than 100% may result in premature battery failure. Batteries are not covered under warranty if they are not recharged properly.
- If batteries are disconnected from the machine and not used for lengthy periods of time, it is recommended to give them a maintenance charge once every two months.

Charging setup

- Ensure you have the correct charger for the batteries. The correct voltage and current is important to ensure the full life of the batteries.
- Check all connections are tight and in good condition.
- The green charger LED will illuminate to confirm charging is in progress.
- If charger lights do not come on, call your service technician.
- When charger is plugged in, drive function of machine is automatically inhibited.

During charging

- Ensure there is enough airflow to help keep the batteries as cool as possible.
- If the batteries are swollen turn off immediately and call your service technician.
- Always leave batteries on charge until the charge is COMPLETE. This is indicated when charger LED turns off.

Charger manual

Please read BA1105—Battery Charger Operating Manual for more information.

Appendix 5: Spare parts list

Part	Description
EDBA1030	Battery—12V 70 Ah
EDBA1105	Charger—24V 7 Amp
EDCL1052	Tiller handle membrane loom
EDCL1130	Loom—charger with socket
EDCL1141	Loom—controller suit tiller
EDCS1030	Grey PU castor—100 mm
EDCS1202	Single Rotacaster wheel
EDEL1041	Battery leads blue/white
EDEL1100	Blanking plug—13mm
EDEL1910	Circuit breaker—40 Amp
EDEL2110	Motor controller—Curtis 1228
EDEL2338	Emergency reverse button
EDEL2380	Emergency stop button
EDEL2450	Fuse 1 Amp (charger) (3AG)
EDEL2470	Fuse 10 Amp (control) (3AG)
EDEL2500	Fuse holder panel mount
EDEL2620	Horn button (optional)
EDEL2720	Key switch with key
EDEL2775	Membrane key pad
EDEL2805	Hour meter 12–48V
EDEL3010	Potentiometer—5k (internal)
EDGM1810	Handgrip 7/8" x 5" —tiller
EDGM2040	Spring—tiller handle position
EDGM2051	Tiller pot spring
EDGM2107	Spring—compression C315-01
EDGM2150	Throttle cable
EDGM2170	Throttle lever for tiller handle
EDGM2210	Tiller pin—zinc plated

Part	Description
EDWHL350T85	Solid rubber wheel
EDWP1049	Tiller handle— complete
EDWP1875	Tiller post
JUR100/JZH	J Series bolt hole castor with 100mm wheel
JUR100/JZP	J Series plate mount castor with 100mm wheel
MOTTRAN450WAL	450W motor and transaxle

Service log

Service recommendations

To ensure this equipment is kept in a safe and reliable condition, it is important to follow a preventative maintenance program. Maintain a log of the service work on the cards below, and always use an approved Electrodrive service agent to conduct the works. Approved service personnel will be provided with all necessary documents and components in service repair, including but not limited to, circuit diagrams, component part lists, descriptions, service checklists and spare parts.

6 month service

Date of service		Service agent	
Machine serial number			
Summary of works			
Next service due			

12 month service

Date of service		Service agent	
Machine serial number			
Summary of works			
Next service due			

18 month service

Date of service		Service agent	
Machine serial number			
Summary of works			
Next service due			

24 month service

Date of service		Service agent	
Machine serial number			
Summary of works			
Next service due			

30 month service

Date of service		Service agent	
Machine serial number			
Summary of works			
Next service due			

36 month service

Date of service		Service agent	
Machine serial number			
Summary of works			
Next service due			

42 month service

Date of service		Service agent	
Machine serial number			
Summary of works			
Next service due			

48 month service

Date of service		Service agent	
Machine serial number			
Summary of works			
Next service due			

54 month service

Date of service		Service agent	
Machine serial number			
Summary of works			
Next service due			

60 month service

Date of service		Service agent	
Machine serial number			
Summary of works			
Next service due			

Solutions to safely push, pull and lift.

www.electrodrive.com.au