

GUIDE RAIL SYSTEMS

**SUITABLE FOR PUMPS
WITH FLANGE CONFORMING
SO7005-92 STANDARD.
WHERE THE SEWAGE CONTAINS
DIRT, CLOTH, FIBRE, ETC.**

INCLUDES

- Guide hook
 - Flange connector
 - Upper guide support
 - Bolts and lock washers
- (Foundation bolts and guide pipes are not included)

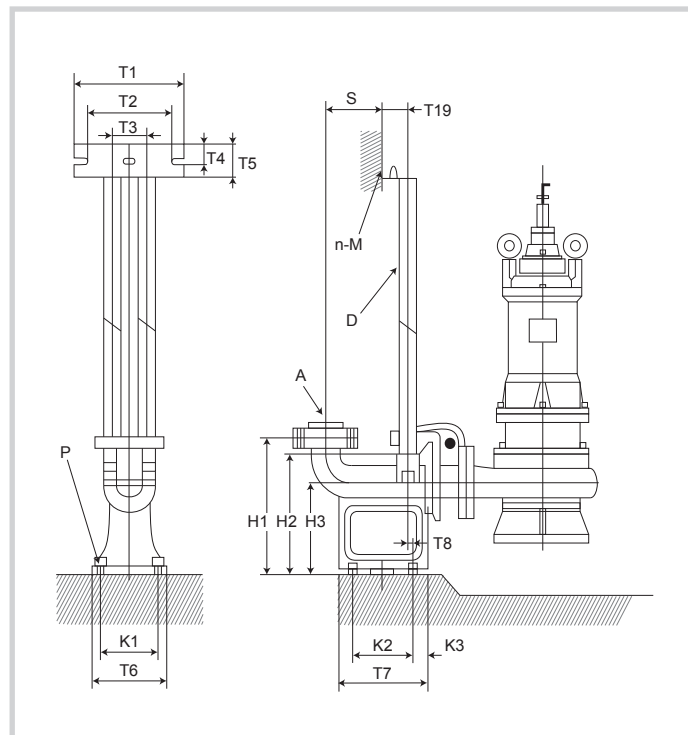
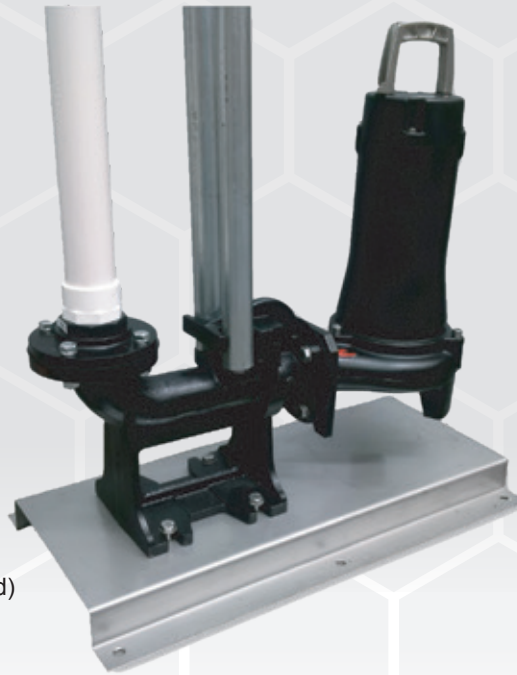

Model	T1	T2	T3	T4	T5	T6	T7	T8	T9	K1	K2	K3	S	H1	H2	H3	D	n-M	P	A
HGRK50-50	288	185	70	25	63	160	200	10	50	120	120	40	125	250	203	170	25	2=M10X40	M16	Ø110/4-Ø14
HGRK65-65	288	185	80	25	63	190	220	10	60	120	120	40	130	250	203	175	32	2=M10X40	M16	Ø130/4-Ø14
HGRK80-80	288	185	80	25	63	220	250	15	60	170	170	40	165	290	242	192	32	2=M10X40	M16	Ø150/4-Ø18