

HiGH-LiFT
EQUIPMENT

Installation and operation manual

TWO POST BASE PLATE CAR HOIST SINGLE POINT RELEASE
SUITABLE FOR THINNER CONCRETE
Model: YL-140B



Mention of no responsibility

- 1: Please check whether the content of articles is in accordance with the list when the customer accepts the equipment. Please check if your equipment is damaged or lost during the transportation while you receive it from the transport company.
- 2: Please check carefully if the package looses when you receive the equipment and disassemble it, to do so to avoid damaging the equipment and injuring the person.
- 3: Please engage the skillful workers and use the proper tools to disassemble the equipment, otherwise the user should be responsible for injuring the person and damaging the equipment .
- 4: You should read the manual carefully before you operate this equipment and your operation must be according with this manual. Otherwise, the user should be responsible for the injury and damage caused by this.
- 5: We have already put safety first during designing and manufacturing. You must also put safety first when you operate and maintenance this equipment.
- 6: The operator must be trained strictly and must have a high sense of responsibility.
- 7: Prohibit operating lift overload.
- 8: When you receive the equipment, please fill in the 'productive warranty card' and post the card to our company in order to assure you rights and interests.

Product Warranty

What is not covered under this warranty:

- a. Any failure that results from purchaser's abuse, neglect or failure to operate, maintain or service product in accordance with instructions provided in the owner's manual(s) supplied.
- b. Any damage caused by overloading lift beyond rated capacity.
- c. Items or service normally required to maintain the product, i.e. lubricants, oil, etc.
- d. Items considered general wear parts such as rubber pads, lifting cables, etc. unless wear or failure is a direct result of manufacturer defect due to material and/or workmanship.
- e. Any component damaged in shipment or any failure caused by installing or operating lift under conditions not in accordance with installation and operation guidelines or damaged by contact with tools or surroundings.
- f. Motor or pump failure caused by rain, excessive humidity, corrosive environments or other contaminants.
- g. Rusted components due to improper maintenance or corrosive environments.
- h. Cosmetic defects that do not interfere with product functionality.
- i. Damage due to incorrect voltage or improper wiring.
- j. Any incidental, indirect, or consequential loss, damage or expense that may result from any defect, failure or malfunction of the product.
- k. All electrical components (excluding power unit) are guaranteed for one year

NOTE

Every effort has been taken to ensure complete and accurate instructions have been included in this manual, however possible product updates, revisions and/or changes may occur post publication. We reserve the right to change specifications without incurring any obligation for equipment previously or subsequently sold. No responsibility taken for typographical errors.

Machine Parameters

- Compact design,minimizes the lift wear parts and breakdown ratio
- Dual hydraulic cylinders,designed and made on standards.
- Self-lubricating UHMW polyethylene sliders and bronze bushings
- Single point security release and dual security design.

Model	YL-140B Two-post Base plate Hoist single point release
Lift Capacity	4500KG
Overall Height	2794mm
Overall Width	3477mm
Power	2.2KW
Voltage	240V 50HZ SINGLE PHASE

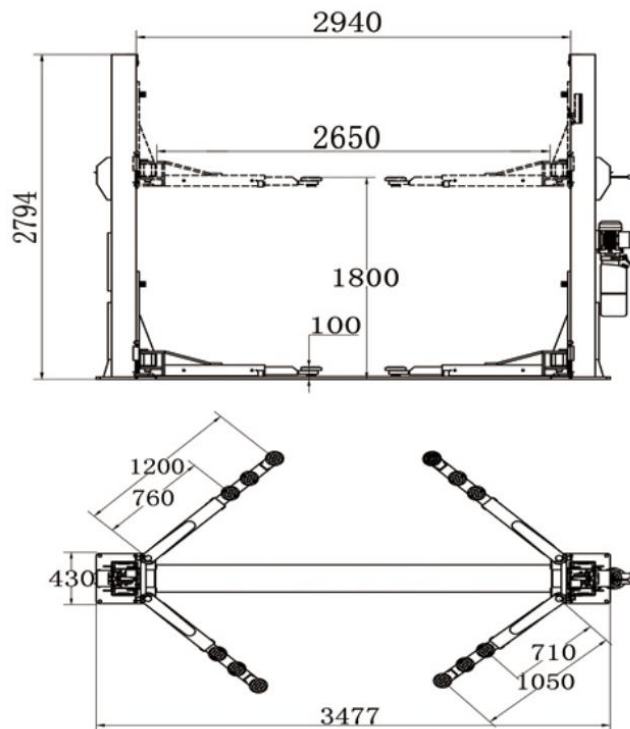

Foundation size

YL-140B BASE PLATE

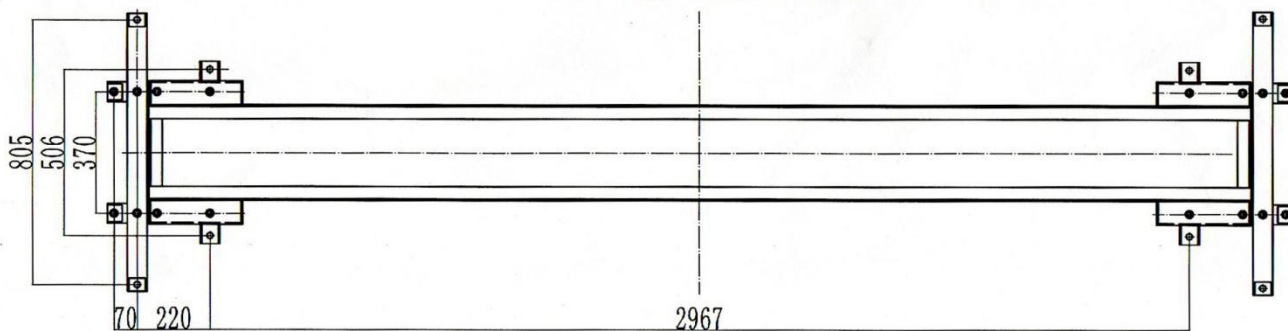

mm

Announcements for safe operation (You must read all of these content)

1. Please read the manual and learn about the safety cautions before you use the equipment.
2. Be careful of your hands and feet, keep them away from the equipment to avoid harm.
3. Keep the environment tidy and clean, the mess workshop will cause accident.
4. Check the work environment of the equipment, not to expose it in the rain, not to use it in wet environment, there must be air through and good sunshine.
5. The operator must be trained strictly, not allow the untrained person to touch and operate the lift
6. Use the lift follow the regulations, we are not responsible for the matters caused by the parts which are not from our company
7. Protect the safe unlock carefully. Check if the safe unlock is reliable before operating.
8. Please attention to keep away when the vehicle is raised or laid down
9. There must be enough space in the workspace to keep away if the automobile which is on the lift is dangerous.
10. The lift must be in mechanical lock position when you maintain the automobile.
11. The operators must have labor protection, they had better take on work shoes which with ferric protection
12. To protect the operator avoid from electric hurt, the earth wire of the motor must be reliable.
13. Notice: There will be sparkle when the switch on and off during the lift working, so the lift can't be operated in the workspace where exists inflammable gas!
14. Notice: You must cut the power supply down before maintaining the electrical equipment of the power unit
15. It's necessarily to have a clean environment and good equipment maintenance. To lubricate and maintenance correctly will help the equipment to reliable. The controlling handle and button must be kept clean and dry and avoid oil dirt.
16. The operator must keep a clear mind during working and must put safety first.
17. Check if there is any damaged part or component. Attention to the synchronous condition between the main support arm and the branch support arm, you must stop operating immediately if you find there is anything abnormal condition, then examine and remove the faults.
18. Don't to disassemble any parts or components related to safety. Otherwise, prohibit operating the lift.
19. Please check if every part is normal and safe carefully (especially if the support pad is in the right position and substance)

20. There not allow being any obstacles which stop the support arm down when to operate the lift to fall off.
21. When the lift raise to the highest limit, the mechanical safe hook must be in position and secure (there must be any sound)
22. When the lift raise to the highest limit, the operator should release the rising controlling button.

Model: YL-140B

install screw list

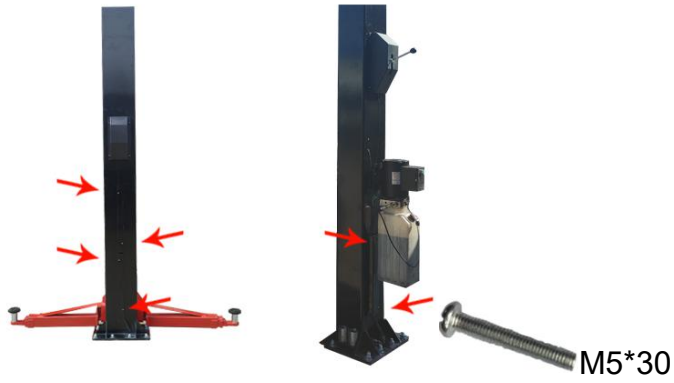

total 6 pcs

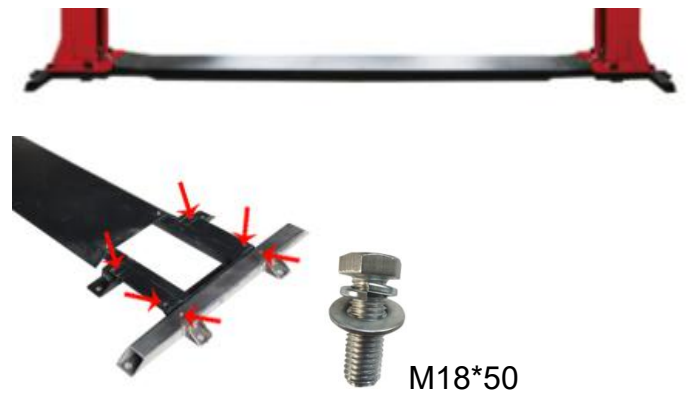

total 12 pcs

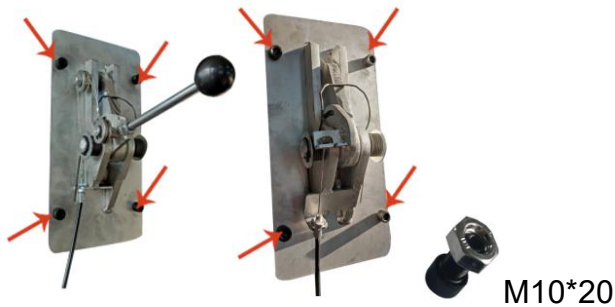

total 8 pcs

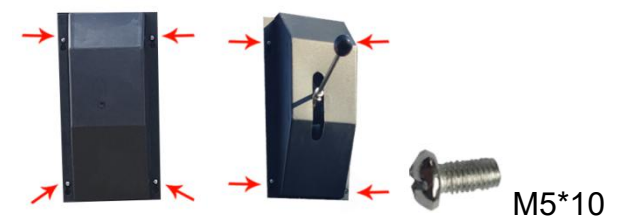

total 8 pcs

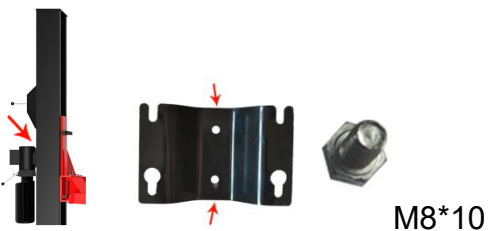

total 2 pcs

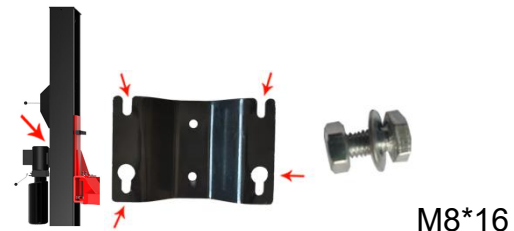

total 4 pcs



total 2 pcs



M4*10
total 3 pcs



total 4 pcs

Installation Guide

impact bit
drill(20mm)
hammer
leveling instrument(300mm)
spanner with crossing groove(8mm~24mm)
angle ruler Adjustable spanner(350mm)
crow bar
tailor's chalk line and chalk
flat head screwdriver and crossing groove head screwdriver
tape measure(5m)
sharp-nose pliers

Rotary Hammer Drill (3/4in /19mm)



Carpenter's Chalk



Hammer



Screw Drivers



Level Bar



Tape Measure [25ft]



Crescent Wrench (12")



Pliers



Ratchet Spanner With Socket (28#)



Allen Head Wrench (6#)



Wrench set
(10#, 13#, 14#, 15#, 17#, 19#, 24#, 27#)



Vise Grips



Steps of installation

Step1 : Choose installation site

Check the follows before installation :

1. Workplace: good building construct, enough work place, no stumbling block to stop working
2. The place where installing the equipment should not be any unsafe element, such as leakage of rain、moist、inflammable、explosive.
3. Foundation of equipment: the installation should coincide with the basement drawings

Step 2: Basement、 ground

1. The basement of the equipment must have the strength which fit to the requirement, otherwise, the lift will crush the ground, cause the damage of equipment and injury & death of people.
2. The installation basement must assure certain levelness, the tolerance is not allowed over 5mm (the tolerance within the extent can be adjusted by using washers)
3. Not allow to install lift on the pitch ground or other non-concrete ground (there must be the solid and reliable basement).
4. Not install lift on the ground with craze or junk concrete ground
5. Prohibit installing lift on second floor or higher floor without the approval of architect.
6. The motor of power unit should be protected by security arrangement. Please not to install the lift outdoor to avoid something wrong with the motor in rainy days.
7. Constructing according to the basement drawing we provided. (the last page)
8. The lift must be installed on the concrete base where the compressive strength is not lower than 200kg/cm², and the thickness of concrete basement is not lower than 300mm, the strength is not lower than 250 class, the just finished concrete basement must be solidified and kept over 28 days.

Step3: The layout of equipment installation

1. Confirm the position of the lift installation first.
2. Confirm the position of the power unit and there must be enough space for the column of the power unit installation.
3. Draw up the position of the baseboard of the column with chalk after the confirmation to assure the tolerance within 3mm to avoid effecting the installation of the lift.
4. Draw up the outline of the baseboard with chalk after the confirmation of the position. (refer to the specifications)
5. Check carefully to assure the layout is correct.
6. Put the two columns in their own position first before installing and connecting the lift, and further watch the position. Attention: When erect the column to assure that there must be enough、no obstacle and no influence of the maintenance working space (advice to choose 4000*7000mm).

Step4: Install the master column

(column with basement of power unit)

1. Check the dimension of the foot margin before installation to assure the baseboard of the column align with the tailor's chalk line.
2. Use the holes on the baseboard of the column as formwork to drill holes on the concrete ground (the drill must perpendicular to the ground). Guarantee the drilling depth (about 160mm), not freely chambering and swing the electric drill.
3. Clean the dust in the hole after drilling and check if the baseboard of the column within the range of the tailor's chalk line.
4. Knock the foundation bolt into the hole (screw the nut on the bolt, not to knock the bolt and nut directly), till the washer contact with the baseboard.
5. If the column is not perpendicular to the ground, you should adjust the gap with thin washer. When you assure the foundation bolt is screwed tighten, the column is perpendicular to the ground.
6. Screw the nut with spanner after the column is perpendicular to the ground, but not to screw tightly for the moment.

Step5: Install slave post

Install the slave column in the position where lineation is finished, and then install the slave stand column. (The step is same to the one for the master column) Screw the foundation bolt of the master column and the slave column tightly and check the verticality of the column again at the same time, otherwise you should adjust the verticality with the appropriate washer till it fits to the requirement.

Notice for using the power unit

1. Not allow to start-up the pump if there isn't any oil in it, lest to destroy the gear pump.
2. The electrical equipment must be kept dry; the damage caused by liquid such as water, acid or detergent isn't in the guarantee range.
3. The damage caused by false connection isn't in the guarantee range.
4. Alone air switch or fuse for the power unit.
5. For 200-240 voltage, 25A fuse is used for single phase.
6. For 380-440voltage, 15A fuse is used for three-phases.

Warning

There is electric spark in the electric circuit when power unit starts, so you can't use the power unit in places where the inflammable gas exists.

safety locking system

Two-post Base plate Lift

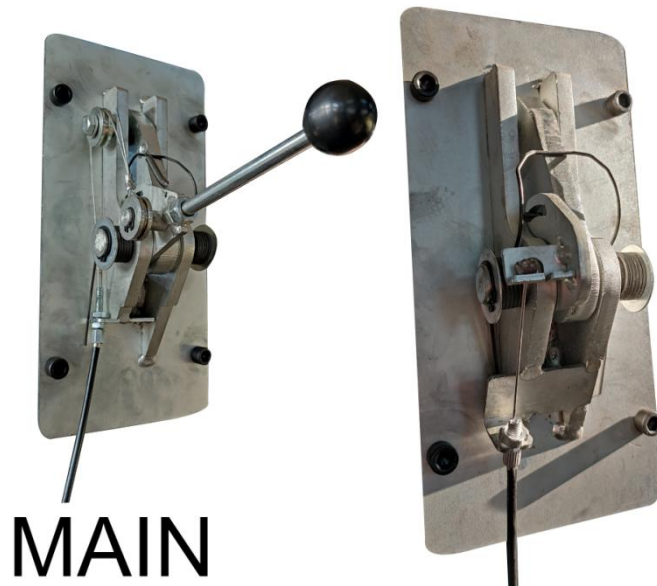
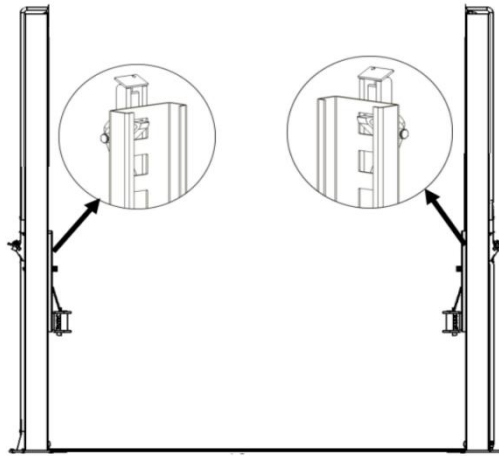

Two-post Base plate Lift

steel cables assemble

Two-post Base plate Lift

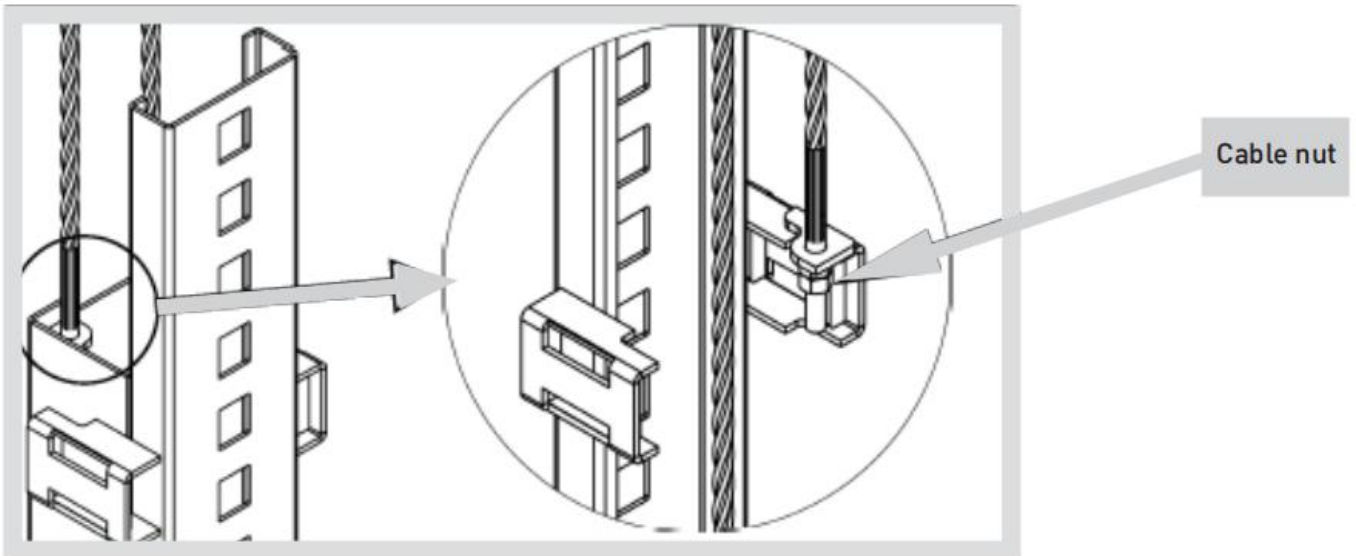
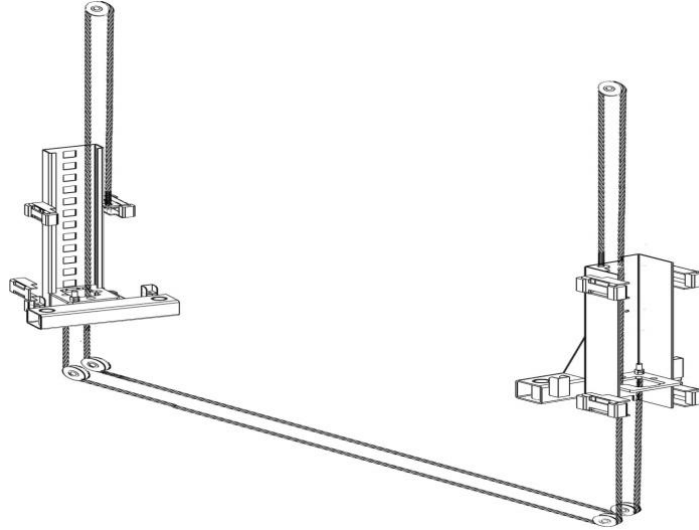

1. ADJUST SYNCHRONIZING CABLES

Carriages must be on first set of locks. Use vise grips to hold the cable fitting, meanwhile, use a wrench to tighten the cable nut. Make sure the two cables have the same tension so the carriages lift at the same time.

If the carriages do not synchronize when lifting, please read below

a. Press UP button to lift the carriages up to the position where the first safety lock of one carriage is higher than the safety lock on the column. Lower the lift until the lower of the two carriages makes contact with the safety lock on the column.

b. Loosen the safety lock cable. Release the safety lock on the side where the carriage is in the higher position. The other side of the safety lock should be engaged at this time. Then lower the lift and the side with the carriage in the lower position will remain locked in the same place and the other side (higher side) is unlocked. Continue to lower down the lift until the higher carriage is at the same level as the lower carriage.

c. Loosen the jam nut on the higher carriage synchronizing cable and tighten the tension nut until

the synchronizing cable has the same tension as the other synchronizing cable. Tighten the jam nut and safety cable

2. ADJUST THE LOWER SPEED

You can adjust the lowering speed of the lift if needed. Loosen the locking nut on the throttle valve and turn the throttle valve clockwise to decrease the lowering speed or counterclockwise to increase the lowering speed. Do not forget to tighten the locking nut after the lowering speed adjustment has been done.

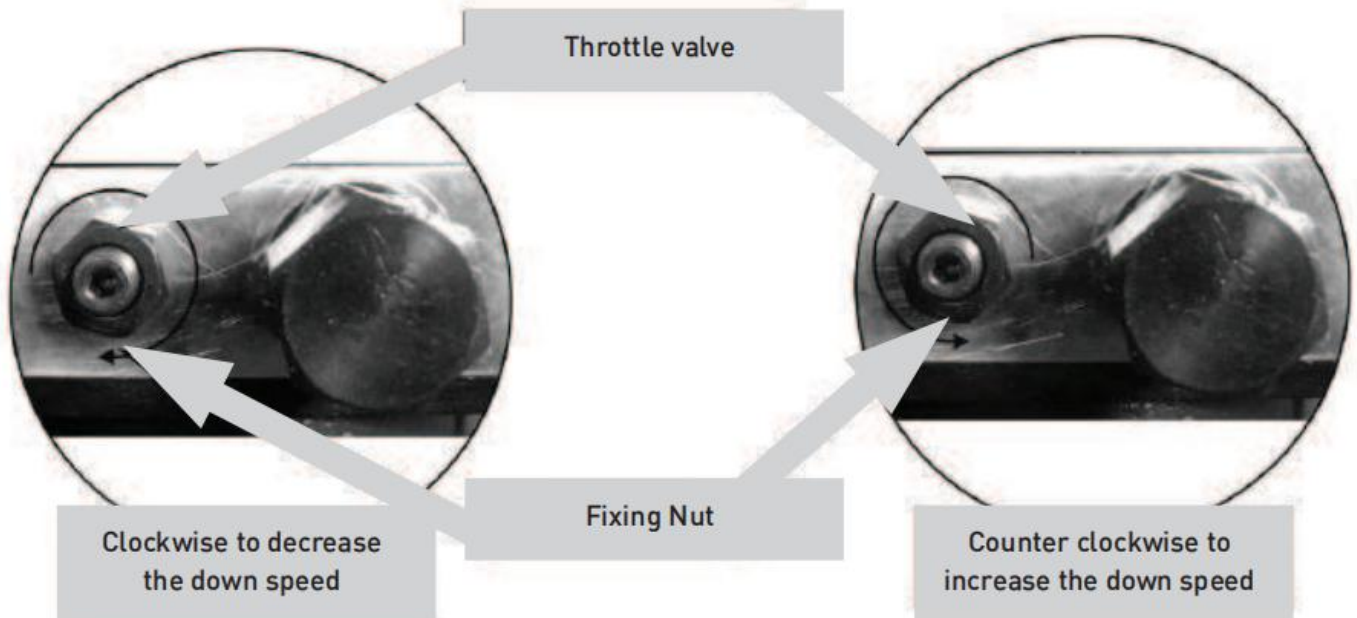

 **DANGER**

DO NOT PERFORM ANY MAINTENANCE OR INSTALLATION OF ANY COMPONENTS WITHOUT FIRST ENSURING THAT ELECTRICAL POWER HAS BEEN DISCONNECTED AT THE SOURCE OR PANEL AND CANNOT BE RE-ENERGIZED UNTIL ALL MAINTENANCE AND/OR INSTALLATION PROCEDURES ARE COMPLETED.

oil tubes

Two-post Base plate Lift

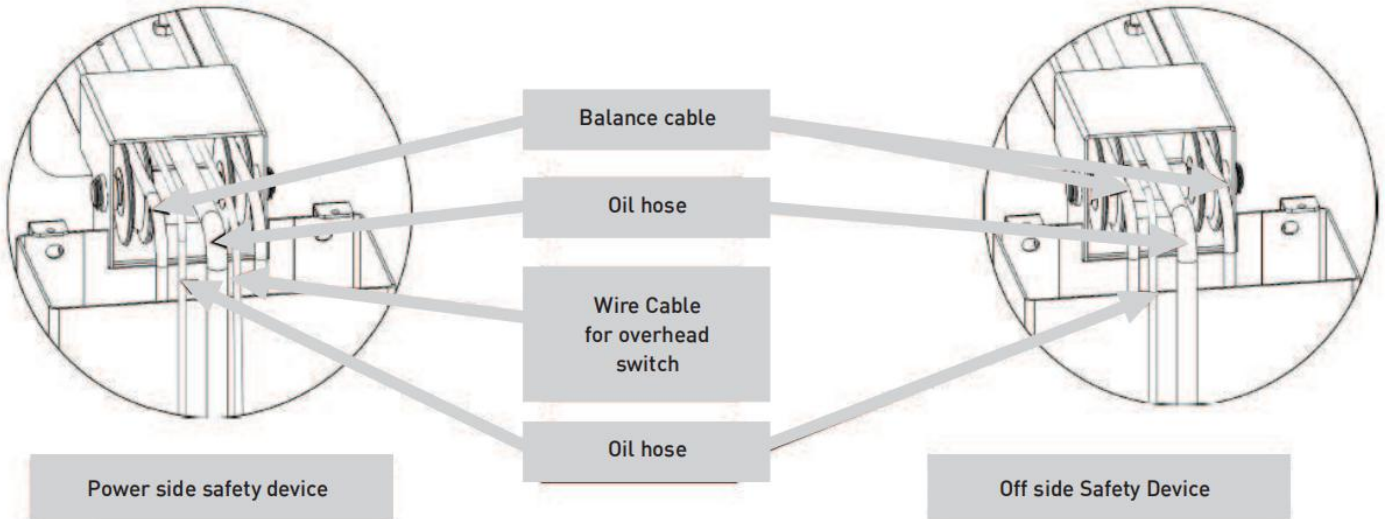
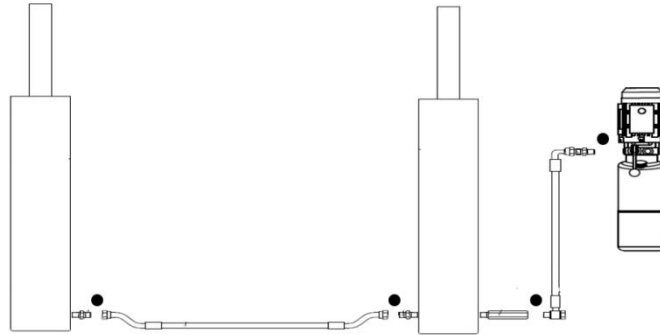

Concrete strength

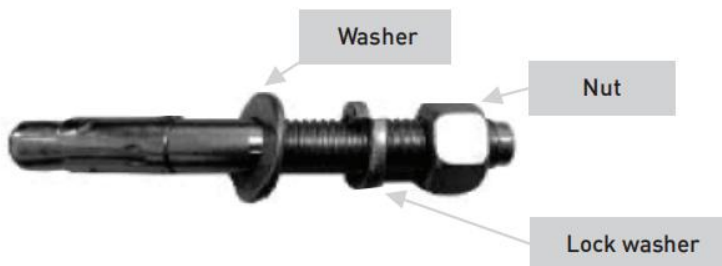
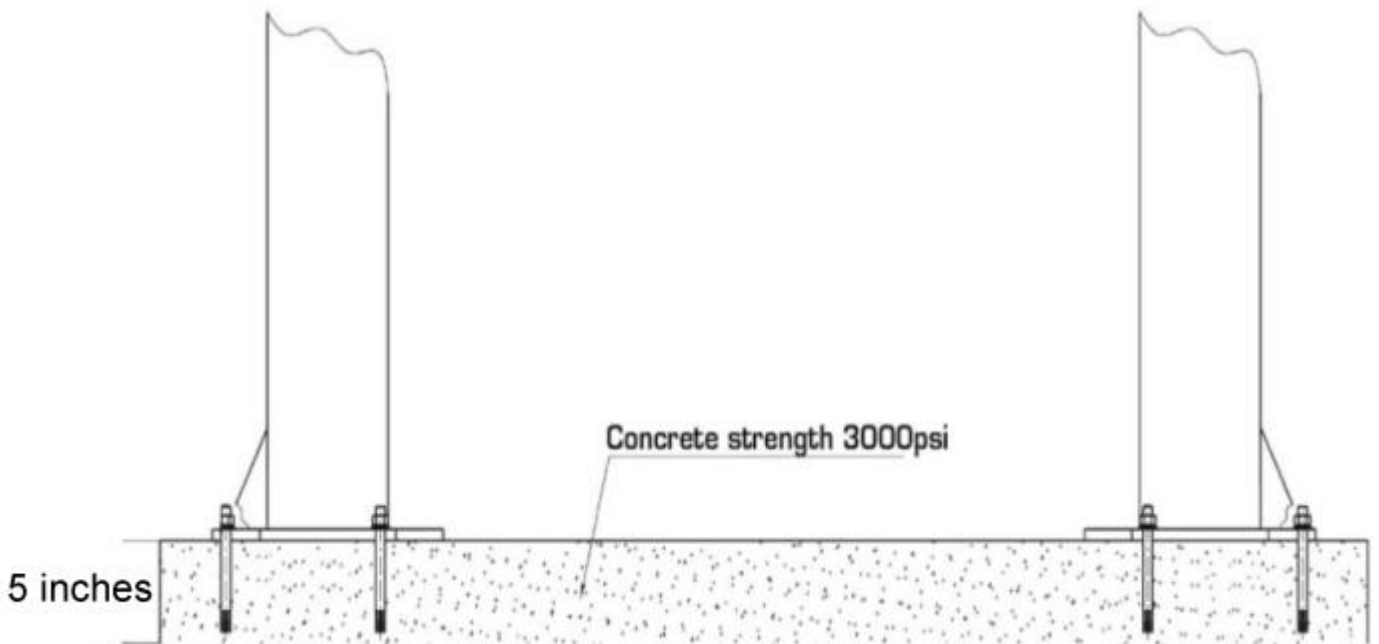

Install Outer Arm

1. Place the appropriate lift arm assembly in the lift heads.
2. Install the lift head pins in to the lift head and through the holes in the arm assembly.
3. Each arm restraint gear can be oriented in a Left or Right configuration on the arms. Each arm and arm restraint gear must be positioned in the proper location in the lift head

4. Install Arm Lock assembly in to the lift

5. Install Arm lock pins in to the lift

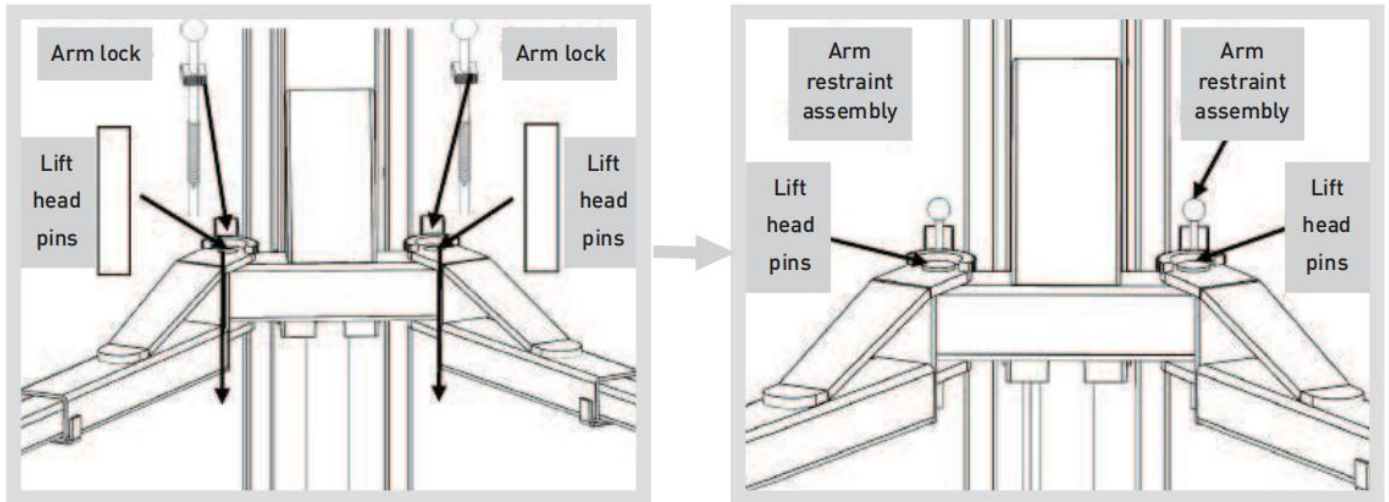

6. Pull up arm lock rod to ensure it is fully unlocked, adjust in this state. Adjust nut as shown.



7. Adjust the arm lock. Follow the arrow direction.

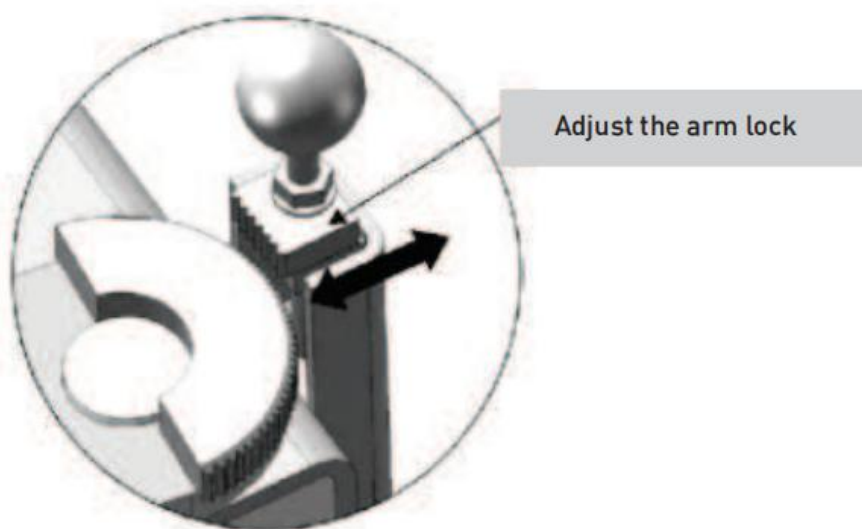

8. Adjust the teeth of arm lock assembly. Make it mesh with the gear on the lifting arm. Tighten the hex bolts on the arm lock assembly.

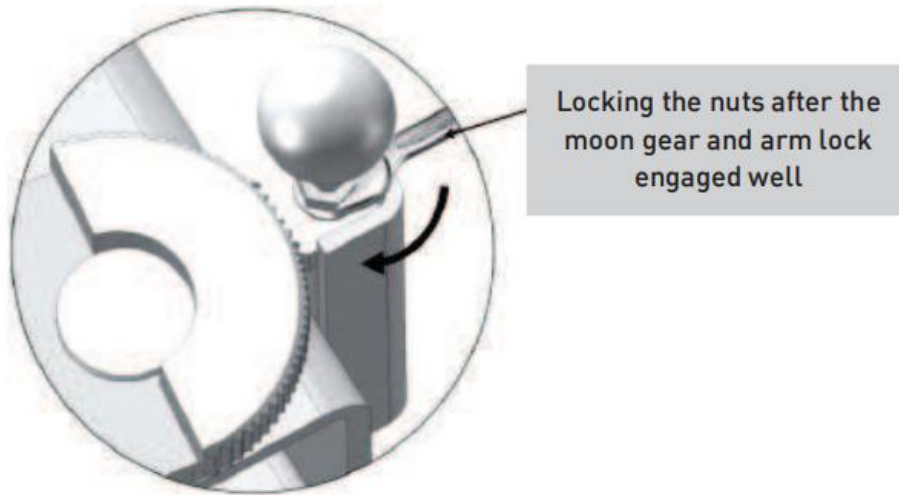

9. Verify the operation of the lift restraints by pulling up on of the arm restraint assembly. Pivot the arms back and forth and test the operation of the arm restraint pin in various positions.

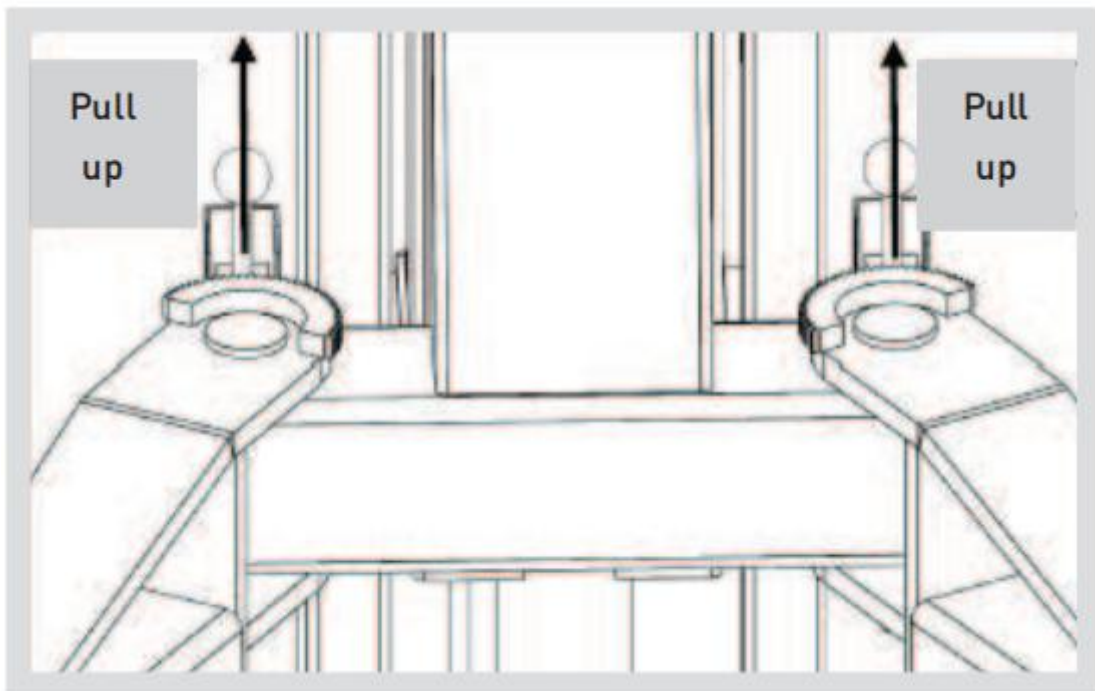

10. Ensure that the arms do not move when a force of approximately 100 pounds or less is applied laterally to the fully extended arms.

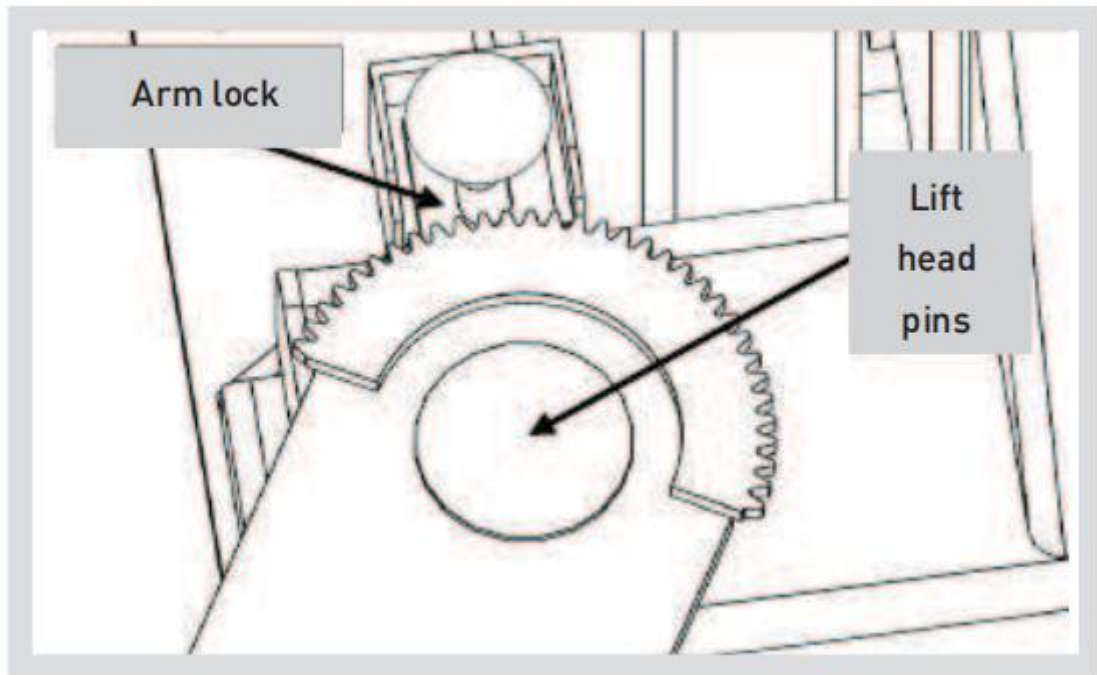

DANGER

NOTE: EACH ARM RESTRAINT ASSEMBLY MUST BE INSPECTED BEFORE EVERY TIME THE LIFT IS OPERATED.
DO NOT OPERATE THE LIFT IF ANY OF THE FOUR ARM RESTRAINT SYSTEMS ARE NOT FUNCTIONING PROPERLY.



WARNING

WHEN LOWERING THE LIFT PAY CAREFUL ATTENTION THAT ALL PERSONNEL AND OBJECTS ARE KEPT CLEAR. ALWAYS KEEP A VISUAL LINE OF SITE ON THE LIFT AT ALL TIMES. ALWAYS MAKE SURE THAT ALL LOCKS ARE DISENGAGED. IF ONE OF THE LOCKS INADVERTENTLY LOCKS ON DESCENT THE LIFT AND/OR VEHICLE MAY DISRUPT CAUSING PERSONAL INJURY OR DEATH.

- **ALWAYS REMOVE** tool trays, stands, etc before lowering lift.
- **ALWAYS RELEASE** safety locks before attempting to lower lift.
- **ALWAYS POSITION** the lift arms and adapters to provide an unobstructed exit before removing vehicle from lift area **TO RAISE THE LIFT.**



WARNING

TO AVOID PERSONAL INJURY AND/OR PROPERTY DAMAGE, PERMIT ONLY TRAINED PERSONNEL TO OPERATE LIFT. AFTER REVIEWING THESE INSTRUCTIONS, PRACTICE USING LIFT CONTROLS BY RUNNING THE LIFT THROUGH A FEW UNLOADED CYCLES BEFORE LOADING VEHICLE ON LIFT. ALWAYS LIFT THE VEHICLE USING ALL FOUR ADAPTERS. NEVER RAISE JUST ONE END, ONE CORNER, OR ONE SIDE OF VEHICLE.

1. Before Loading: Lift must be fully lowered and service bay clear of all personnel before the vehicle is brought on lift with the swing arms set to the full drive-thru position.
2. Loading: Swing arms under vehicle and position adapters at vehicle manufacturer's recommended lift points. Use height extenders or optional frame cradle adapters when necessary to ensure good contact.
3. Some vehicles may have the manufacturer's Service Garage Lift Point locations identified by triangle shape marks on the undercarriage (reference ANSI/SAE J2184- 1992). Also, there may be a label located on the right front door jamb area showing specific vehicle lift points.



WARNING

MANY SPECIALTY OR MODIFIED VEHICLES CANNOT BE RAISED ON A TWO-POST FRAME ENGAGING LIFT. CONTACT VEHICLE MANUFACTURER FOR RAISING OR JACKING DETAILS

- Position vehicle for proper weight distribution arms under vehicle to allow adapters to contact at the manufacturer's recommended pick up points.

TYPICAL LIFTING POINTS

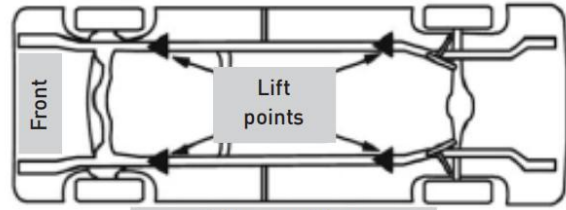

Pickup truck/van

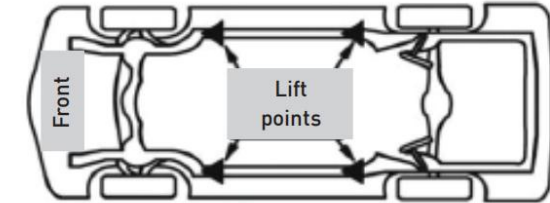

Perimeter frame

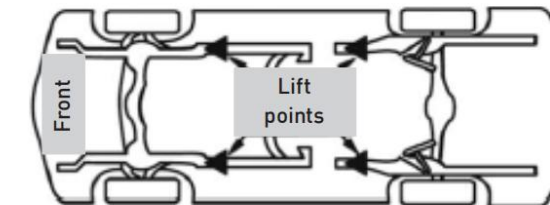

Stub frame

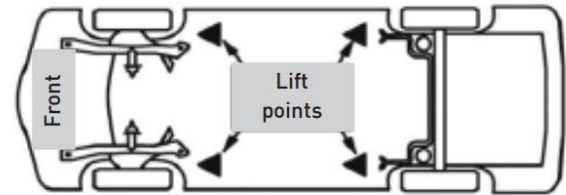

Unitized Body

- Push the RAISE button or rotate the control switch on the power unit

NOTE: ALLOW (2) SECONDS BETWEEN MOTOR STARTS. FAILURE TO COMPLY MAY CAUSE MOTOR BURNOUT.

- Stop before making contact with vehicle. Check arm restraint pins for engagement. If required, slightly move arm to allow restraint gear and pawl to mesh. **DO NOT** hammer arm restraint pin down as this will damage the restraint gear teeth.
- Raise vehicle until tires clear the floor.
- Stop and check adapters for secure contact at vehicle manufacturer's recommended lift points.
- Continue to raise to desired height only if vehicle is secure on lift.
- **DO NOT** go near or under a raised vehicle if all four adapters are not in secure contact with vehicle at vehicle manufacturer's recommended lift points.
- Repeat entire loading and raising procedures if required.
- Lower lift onto safety locks.

Exhaust and Debug

1. You need to exhaust and debug when you finish the lift installation.
2. Fill the oil tank with enough oil (not too full) and press the down-up button after connecting the electric power, then the lift up and the hydro-cylinder works.
3. Make the lift continue to rise till to the highest position, and then not to press the button anymore to avoid damaging the power unit.
4. Keep 10 seconds after rising to the highest position.
5. Pull out the lock release steel wire rope and press the down-handle which on the power unit, then down the lift.
6. If there is any phenomenon such as jump or unbalance exist when the lift fall off,you should adjust the balance wire rope repeat for many times, the car can be drove-on the lift when the balance is guaranteed.
7. Start-up the motor and press the up-down button, then the lift rising, it's normal for the slight 'jump' phenomenon from the cylinder.

Maintenance

1. Check if the support arm can be operated normally every class.
2. Check if the bolt and the hinge pin became free every class, tighten them when they are free.
3. Check if the safe device is reliable ever class.
4. Lubricate the slider which in the column and the entire axle chain every week (you can do this depends on the reality).
5. Check if the foundation bolt is free or not, and tighten them when they are free.
6. Check if the column is deformed and perpendicular to the ground at regular intervals.
7. Check if the telescopic boom turns flexible and works reliable every class.
8. Check if the support pad is worn at regular intervals or it need to be changed.
9. Change the hydraulic oil every 500 working hours of the lift. You can change oil once within 1~1.5years when the lift is not used or not used frequently.

Troubleshooting

1 The lift doesn't work

The possible failure	The reason and resolution
There is air in the oil	Deflate according to exhaust and debug
High oil viscosity caused by oil solidification or working temperature is too low	Let the high viscosity oil out and refuel the regular oil.
The hydraulic oil is leak.	Check if each pipe connector is tighten up.
	If the oil seal on the cylinder is deformed and warp.
The motor is reverse.	If the connection is right reference to the circuit diagram.
The motor doesn't work.	Something is wrong with the motor, change the motor.
	Lack of phase、 fail line or wrong voltage.
	The fuse is broken.

2 The lift doesn't work when it is on load

The hydraulic oil is Leak.	The pipe connector become flexible, tighten it again.
	There is leakage in the cylinder oil seal, change the cylinder.
The motor voltage is wrong	Install press regulation system
The load is over the lift capability	Check the lift capability (not to operate over it) .

3 The lift doesn't lift off or lift much slowly.

The lift is in lock.	Up the lift, then unlock and press the down button.
The viscosity of hydraulic oil is too high.	Change to regular oil.
The insert valve is blocked.	Separate the valve parts and clean them.
The pipe parts is blocking	Unscrew the pipe connector, then check and clean the blocking section.

4 Oil leakage outside

Joint of pipe connector is flexible.	Retighten the pipe connector
Oil leak from the air hole.	Change the sealing when sealing failure in the hydraulic cylinder.
Oil is too much and flow from the container.	Decrease the oil quantity properly.

5 The sound is uncommon

Air in oil.	Resolve as the former way.
Overload.	Check the lifting capacity (prohibit to overload) .
Bolts of the motor are flexible.	Screw up the bolts.
Lubricant oil is short of in the rolling position.	Refuel lubricant oil.