

Standard Accessories

ITEM	MODEL	SJ-10i	SJ-10iM	SJ-20	SJ-20MC	SJ-20i	SL-8	SL-10	SL-8MC	SL-10MC
3-Jaw Hydraulic Chuck		●	●	●	●	●	●	●	●	●
Manual Hydraulic Tailstock				●	●		●	●	●	●
Hydraulic System		●	●	●	●	●	●	●	●	●
Coolant System		●	●	●	●	●	●	●	●	●
Auto Lubrication System		●	●	●	●	●	●	●	●	●
Heat Exchanger		●	●	●	●	●	●	●	●	●
Working Light		●	●	●	●	●	●	●	●	●
Hand Wheel		●	●	●	●	●	●	●	●	●
Foot Switch For Chuck Clamp		●	●	●	●	●	●	●	●	●
OD Tool Holder		●	●		●	●			●	●
Facing Tool Holder				●	●		●	●	●	●
Boring Bar Holder & Sleeves		●	●	●	●	●	●	●	●	●
Drill Sleeves				●			●	●	●	●
Live Center MT#4				●	●		●	●	●	●
Tool Box		●	●	●	●	●	●	●	●	●
Levelling Pad		●	●	●	●	●	●	●	●	●
Operation & Maintenance Manual		●	●	●	●	●	●	●	●	●
Tool Sleeves				●			●	●	●	●
Power Turret					●				●	●
Warning Light (Tri-Color Light)		●	●	●	●	●	●	●	●	●

Optional Accessories

ITEM	MODEL	SJ-10i	SJ-10iM	SJ-20	SJ-20MC	SJ-20i	SL-8	SL-10	SL-8MC	SL-10MC
Chip Conveyor		▲	▲	▲	▲	▲	▲	▲	▲	▲
Chip Bucket		▲	▲	▲	▲	▲	▲	▲	▲	▲
Transformer		▲	▲	▲	▲	▲	▲	▲	▲	▲
Parts Catcher		▲	▲	▲	▲	▲	▲	▲	▲	▲
Tool Setter				▲	▲		▲	▲	▲	▲
Auto Door		▲	▲	▲	▲	▲	▲	▲	▲	▲
Auto Bar Feeder		▲	▲	▲	▲	▲	▲	▲	▲	▲
Bar Feeder Interface (LNS System)		▲	▲	▲	▲	▲	▲	▲	▲	▲
CE Mark		▲	▲	▲	▲	▲	▲	▲	▲	▲
Power Tool Holder			▲		▲				▲	▲
Collet Chuck		▲	▲	▲	▲	▲	▲	▲	▲	▲

Above specifications are subject to change without notice.

ECOCA[®]
—Focus on every detail—

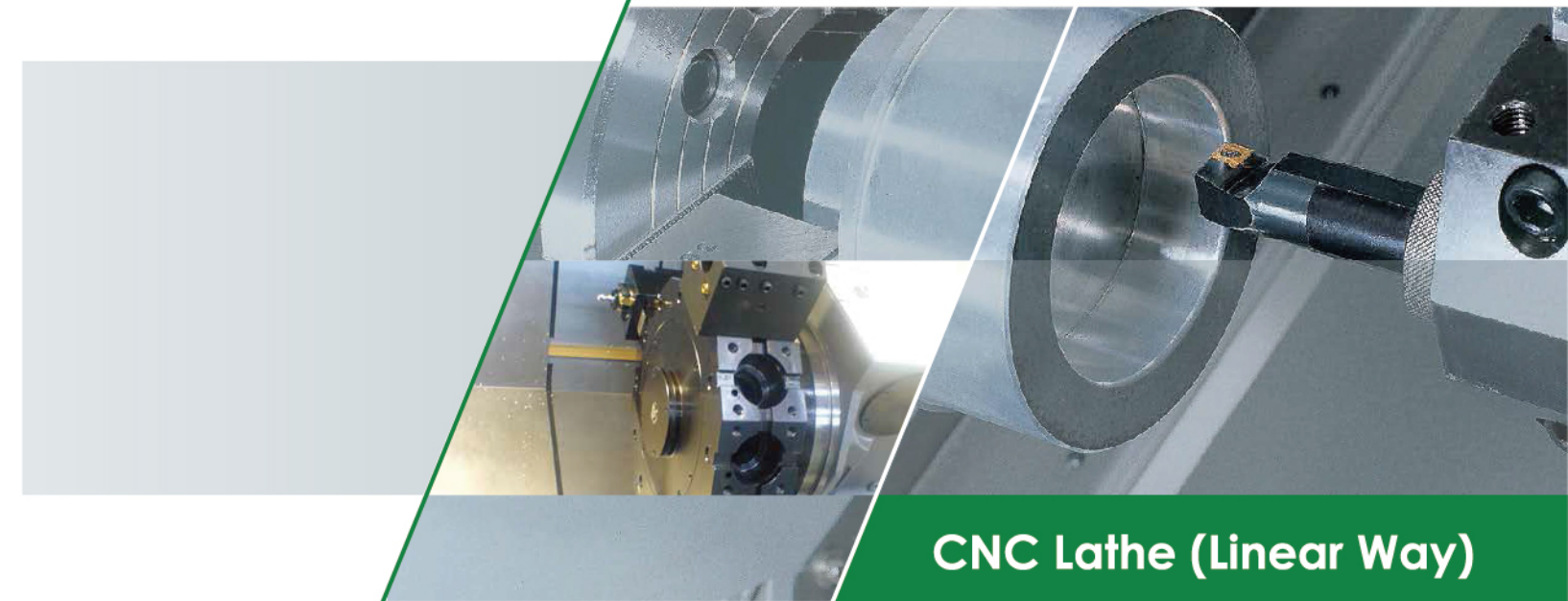

CNC Lathe (Linear Way)

SJ-10i(M)
SJ-20i
SJ-20(MC)
SL-8/10(MC)



友嘉實業股份有限公司
ECOCA事業部
FAIR FRIEND ENTERPRISE CO.,LTD.
ECOCA DIVISION

36744苗栗縣三義鄉西湖村伯公坑40-33號
No.40-33, Bogongkeng, Sanyi Township,
Miaoli County 36744, Taiwan
TEL:+886-37-877059 <http://www.ecoca.com>
FAX:+886-37-877071 E-Mail:biz@ecoca.com



SJ series
SL series

SJ-10i/10iM/20i GANG TYPE CNC LATHE

SJ-20/20MC COMPACT CNC LATHE

- The gang-type tool holder system has high-precision and rapid tool change positioning, saving tool change time and increasing production efficiency.
- Configurable power tool holder system (axial/radial) for machining, drilling, tapping and other machining capabilities.

- Small floor space and more flexible production line planning.
- The 45-degree slant bed design provides a good chip evacuation function, one piece casting enhance rigidity and suitable for heavy cutting.
- Highly rigid linear guideways for fast and precise cutting performance and increasing production efficiency.



Gang Type Power Tool Holder



Automatic Bar Feeder

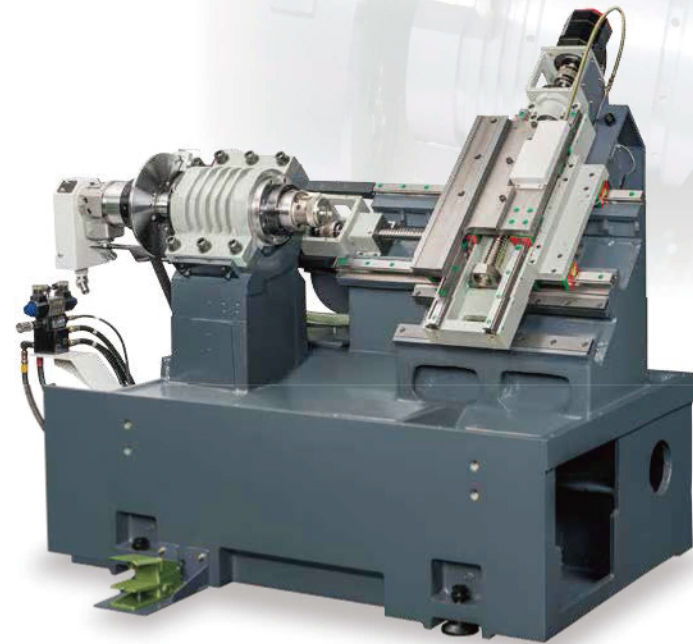

Tool Setter (Opt.)

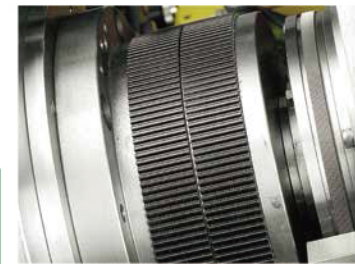

High Resolution Encoder (Opt.)



Parts Catcher (Opt.)

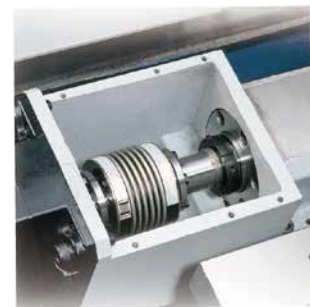

High Quality Flexible Coupling Ensures Smoothness And Precision Of Axial / Longitudinal / Angular Motion

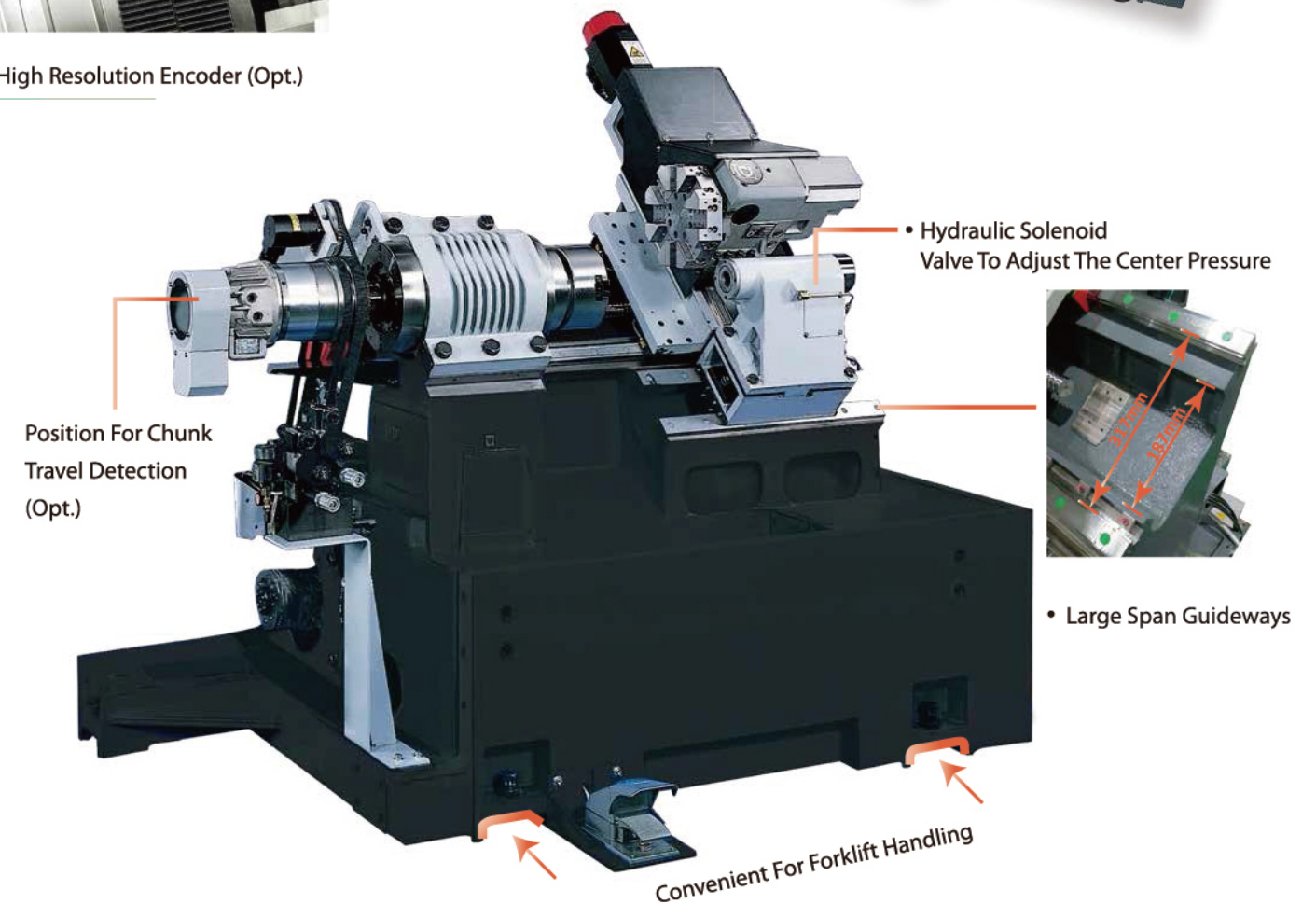

Torque Diagram

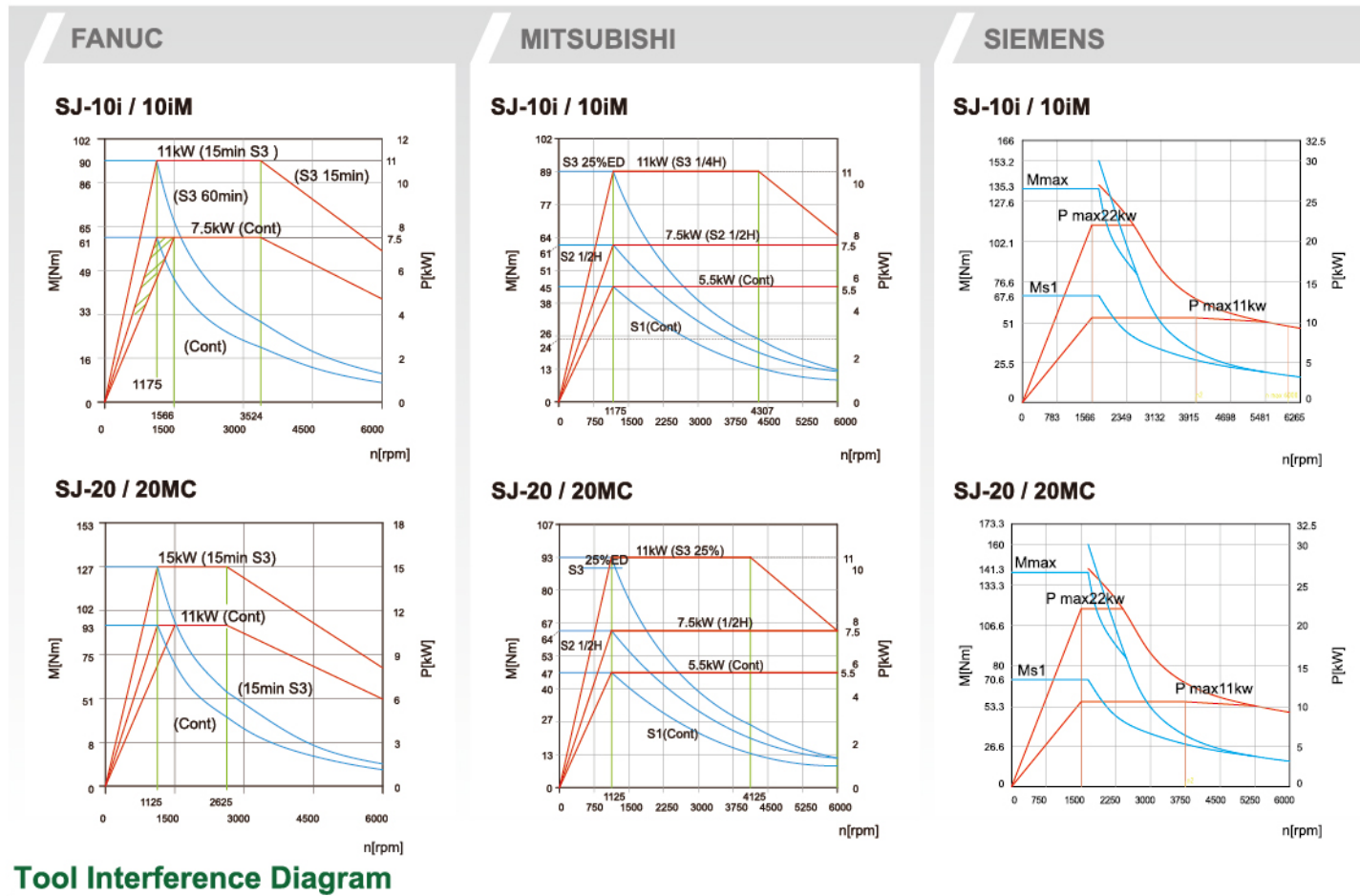

Tool Interference Diagram

LS-120 8T
SJ-20

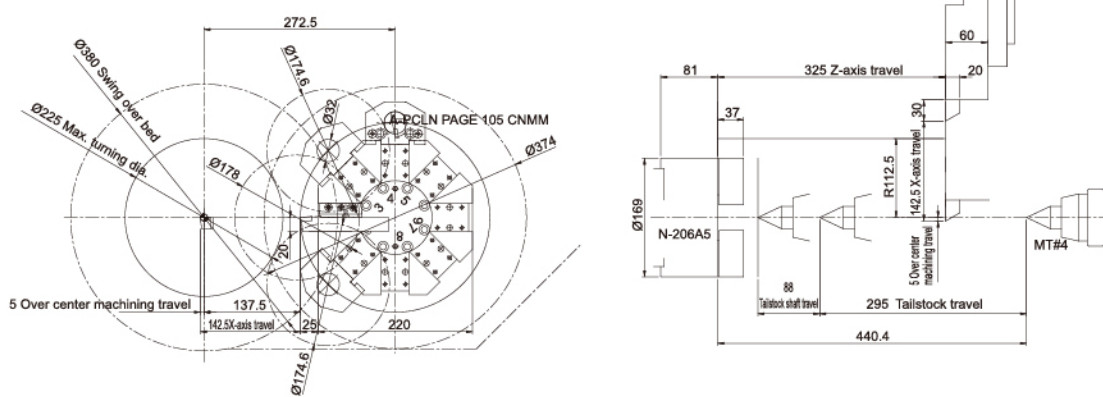

TBMA-120 12T
SJ-20MC

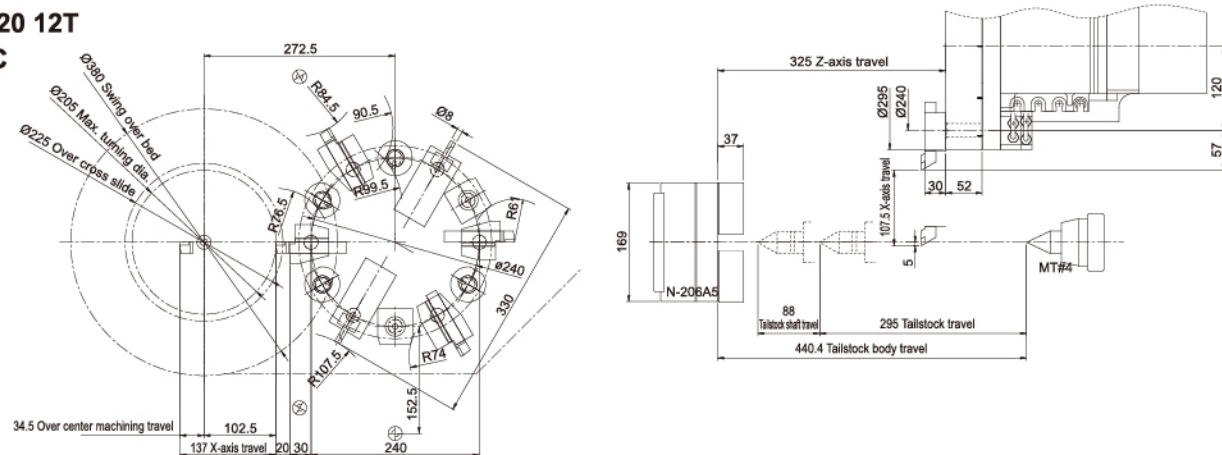

SL-8/10 COMPACT CNC LATHE

Meet A Variety Of Metal Processing Requirements



Tool Setter (Opt.)

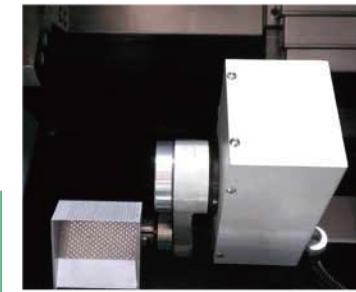

Parts Catcher (Opt.)



Chip Conveyor (Opt.)

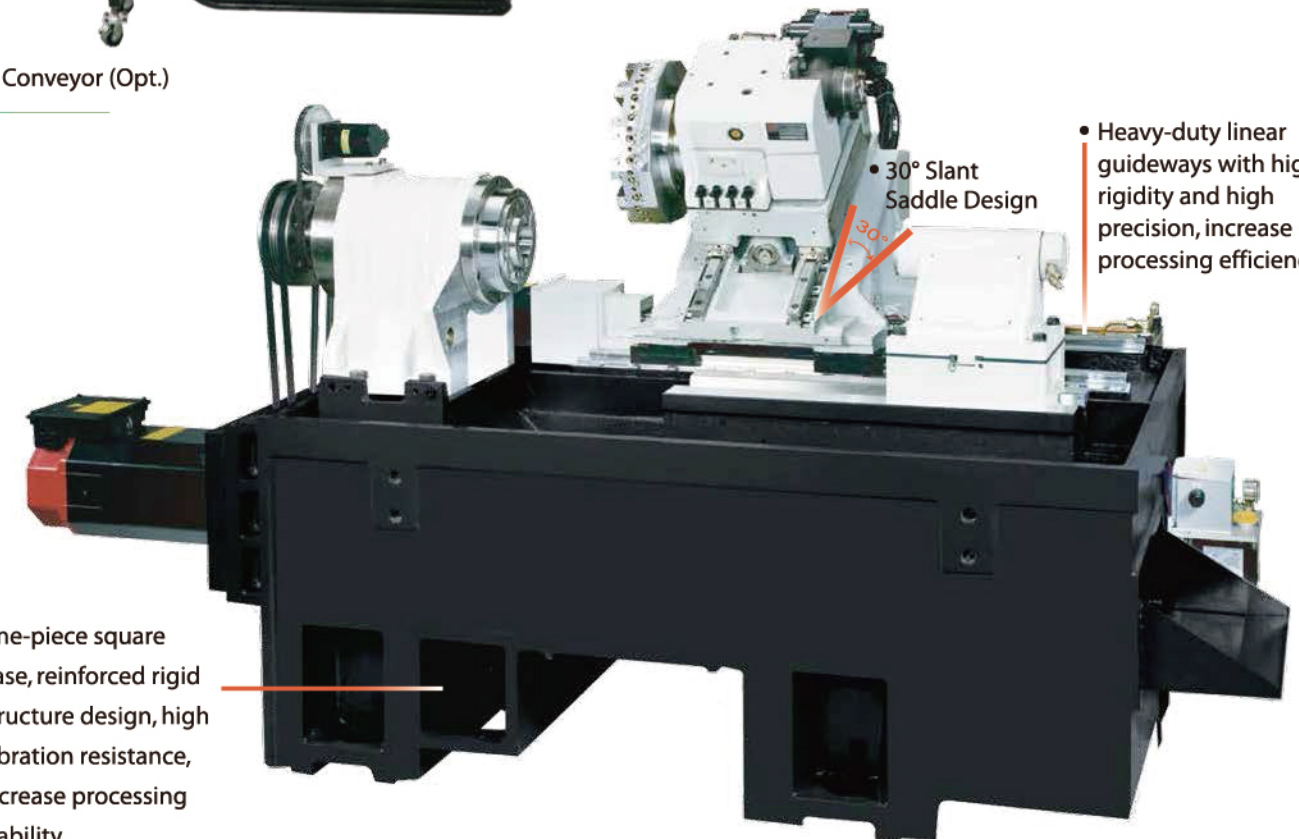

• Heavy-duty linear guideways with high rigidity and high precision, increase processing efficiency.

• One-piece square base, reinforced rigid structure design, high vibration resistance, increase processing stability.

Torque Diagram

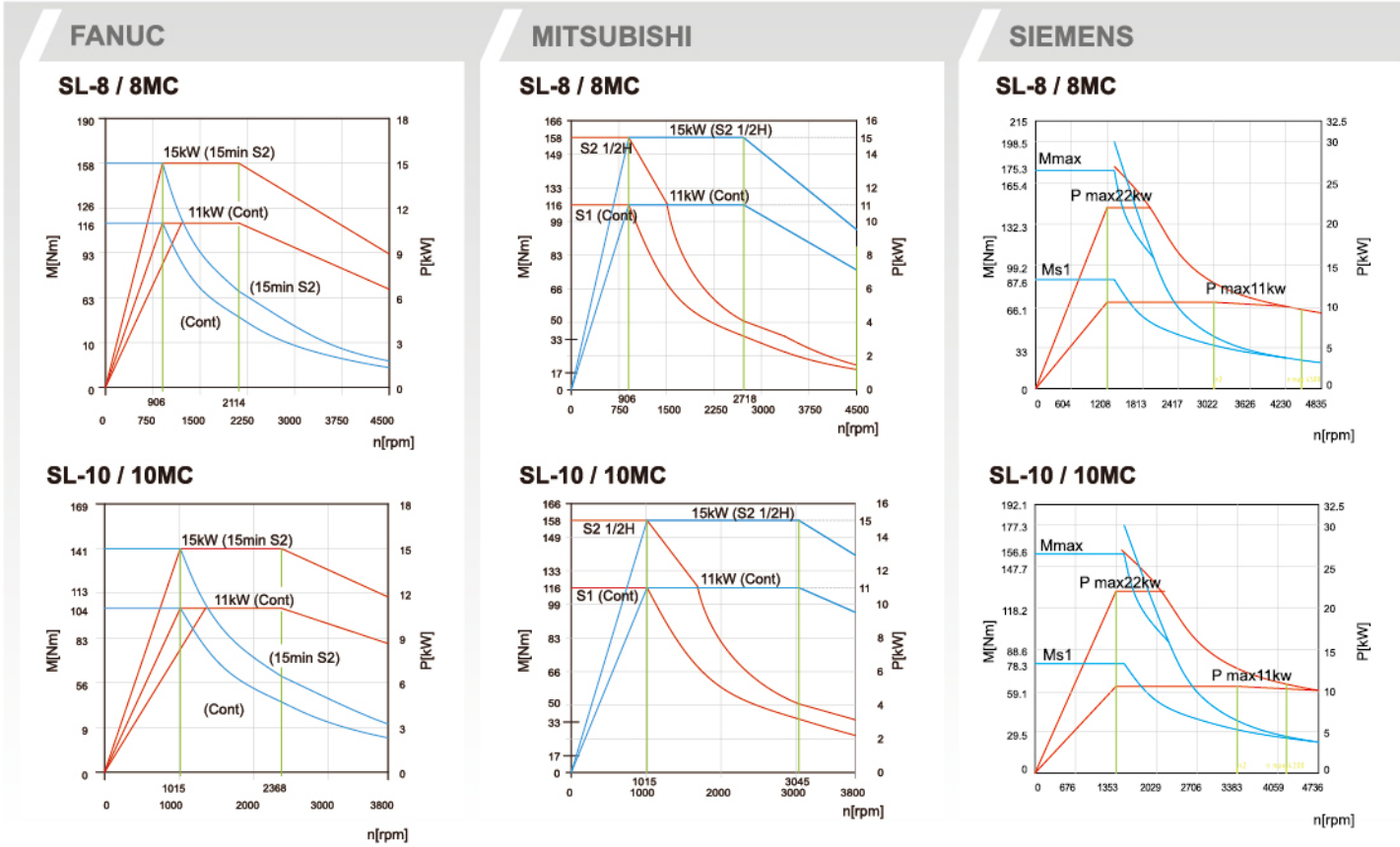

Tool Interference Diagram

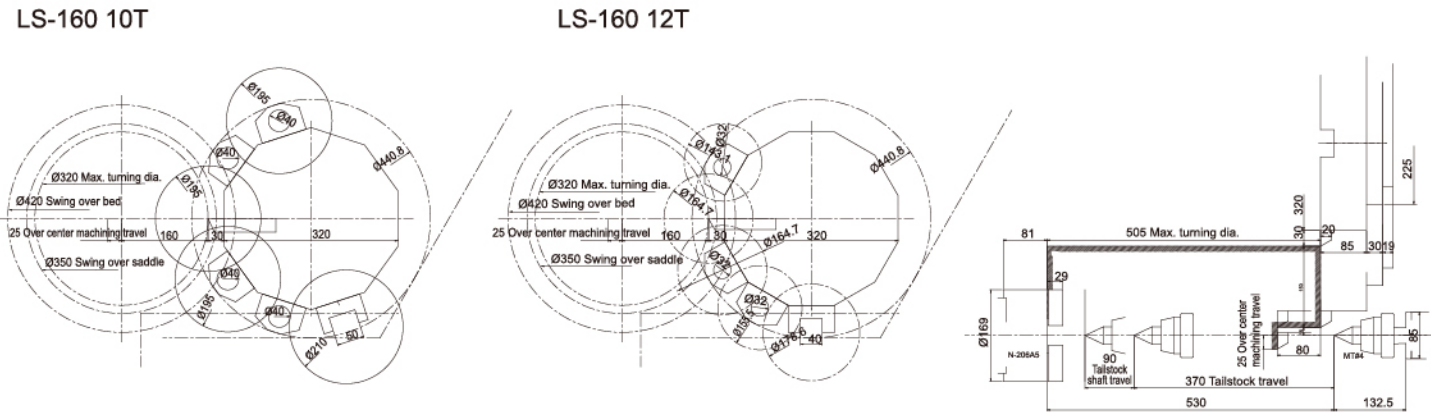

Turret

VDI Disc (Opt.)

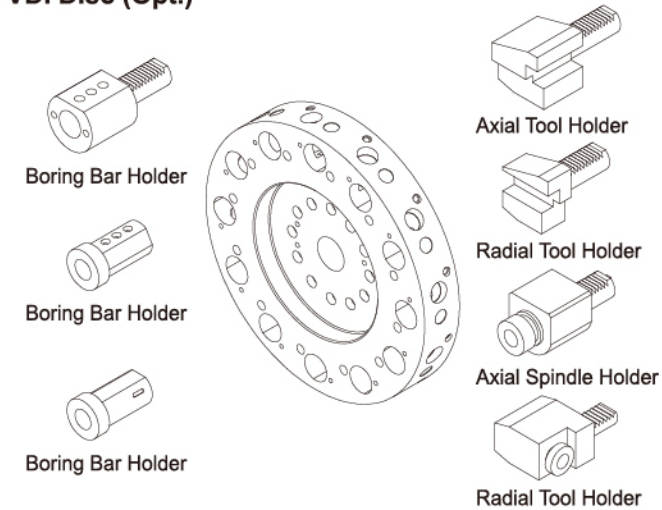

Hydraulic Disc

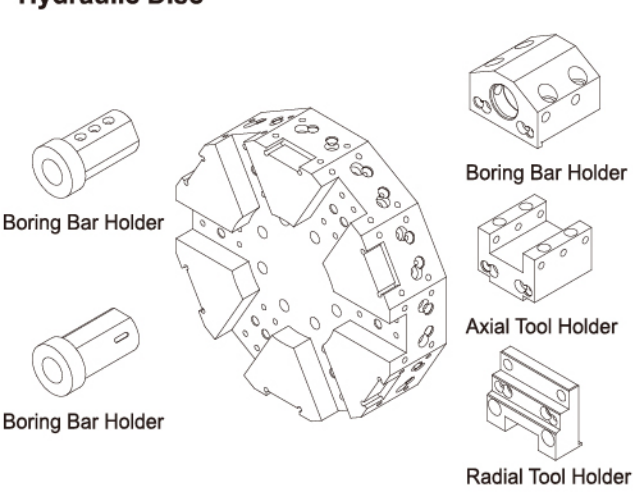

Mechanical Specifications

ITEM	MODEL	SJ-10i	SJ-10iM	SJ-20i	SJ-20	SJ-20MC	SL-8	SL-8MC	SL-10	SL-10MC	
Swing Over Bed	mm	380					420				
Over Cross Slide	mm	160	160	225	205	340	340	340	340	340	
Max. Turning Dia.	mm	100	100	225	205	320	220	320	320	220	
Max. Turning Length	mm	330	330	325	325	480	480	460			
Chuck Size	inch	5	6	6 (opt:8")	6	8	8	10			
X-Axis Travel	mm	360	360	142	137	180					
Z-Axis Travel	mm	330	330	325		480	480	480			
Max. Spindle Speed	rpm	6000	6000 (opt:4500)	6000 (opt:4500)	6000	4500	4500	4200			
Power Tool Speed	rpm	-	4000	-	-	4000	-	4000	-	4000	
Spindle Nose	ASA	A2-4	A2-5 (opt:A2-6)		A2-5	A2-6	A2-6	A2-8			
Through Spindle Hole Dia.	mm	45	51 (opt:62)		51	62	62	90			
Draw Tube Dia.	mm	32	45/52		45	52	52	75			
Front Bearing Dia.	mm	70	80/100		80	100		130			
Number Of Tool Position		6	4	8 (opt:12)	12	10	12	10	12		
Size Of External Turning Tool	mm	16	20	20 (opt:16)	16	25	20	25	20		
Boring Bar Dia.	mm	20	32	32 (opt:25)	25	40	32	40	32		
Rapid Traverse (X/Z Axis)	m/min	24	20	20		20 (opt:30)		20 (opt:30)			
Quill Dia.	mm	-	-	58		58		58			
Quill Taper		-	-	MT#4		MT#4		MT#4			
Quill Travel	mm	-	-	88		88		88			
Tailstock Travel	mm	-	-	295		370		370			

MITSUBISHI										
Controller Type		M80	M80	M80	M80	M80	M80	M80	M80	M80
Spindle Drive Motor	KW	5.5/7.5	5.5/7.5	5.5/7.5	11/15	11/15	11/15	11/15	11/15	11/15
X-Axis Motor	KW	1.5	1.5	1.5	2.2	2.2	2.2	2.2	2.2	2.2
Z-Axis Motor	KW	1.5	1.5	1.5	2.2	2.2	2.2	2.2	2.2	2.2
Power Tool Motor	KW	-	0.75	-	-	2.2	-	2.2/3.7	-	2.2/3.7

FANUC										
Controller Type		Fanuc 0i-TF			Fanuc 0i-TF			Fanuc 0i-TF		
Spindle Drive Motor	KW	7.5/11			11/15			11/15		
X-Axis Motor	KW	1.2	2.5	2.5	2.5	2.5	2.5	2.5	2.5	2.5
Z-Axis Motor	KW	1.2	2.5	2.5	2.5	2.5	2.5	2.5	2.5	2.5
Power Tool Motor	KW	-	0.75	-	-	1.5/2.2	-	2.2/3.7	-	2.2/3.7

SIEMENS										
Controller Type		828D			828D			828D		
Spindle Drive Motor	KW	9			11			11		
X-Axis Motor	KW	1.5	1.7	1.7	1.7	2.85	2.85	2.85	2.3	2.3
Z-Axis Motor	KW	1.5	1.7	1.7	1.7	2.85	2.85	2.85	2.3	2.3
Power Tool Motor	KW	-	1.4	-	-	1.4	-	2.8	-	2.8

Coolant Tank Capacity	Liter	110					100					
Floor Space (LxW)	mm	1800x1450					2550x1550			2700x1600		
Net Weight	kg	3000	3000		3300	3350	3450	3450	3450	3550		

Above specifications are subject to change without notice.

Machine Dimensions

SJ-10i/10iM/20/20MC

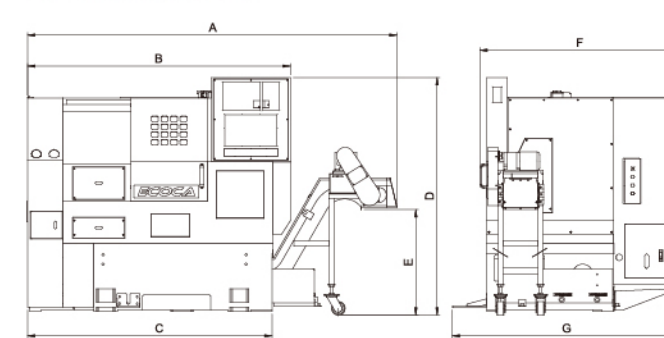

MODEL	A	B	C	D	E	F	G
SJ-10i/10iM/20/20MC	2712	1930	1795	1744	775	1474	1670

SL-8/8MC/10/10MC

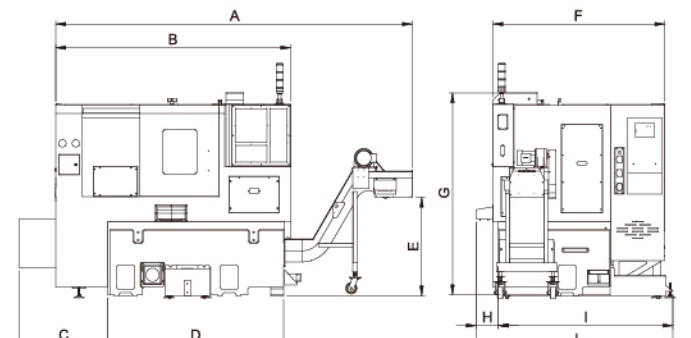

MODEL	A	B	C	D	E	F	G	H	I	J
SL-8/8MC/10/10MC	3226	2124	803	1590	893	1506	1832	152	1578	1780