



Baler Dimensions

Height	2 507 mm
Width	3 260 mm
Depth	1 274 mm
Transportation Height	1 955 mm
Power Supply	240V 1 Phase
Motor	2.2kW 15A
Pressing Force	Up to 16T
Noise Level	74 dB
Cycle Time	34 Seconds

Bale Dimensions

Height	1 000 mm
Width	1 194 mm
Depth	798 mm
Weight	Up to 200kg

Baler Features

- Saves handling time with multiple chambers, available for loading, even when the compaction head is active
- Multiple chambers offer an efficient way of separating different materials before baling
- Retaining claws prevent spring back
- Top loading machine
- Suitable for areas with height restrictions
- Fully automated bale ejector to simplify removal of bale
- PLC Panel with automatic compaction cycles
- Bale full light
- 2 year warranty

Optional Extras

- Up to 6 additional chambers can be added
- Compaction head parking bay to free up all chambers
- Galvanised finish

Loading Aperture Sizes

Depth	798 mm
Width	1 074 mm



Dimensions and technical information without obligation. Subject to change.

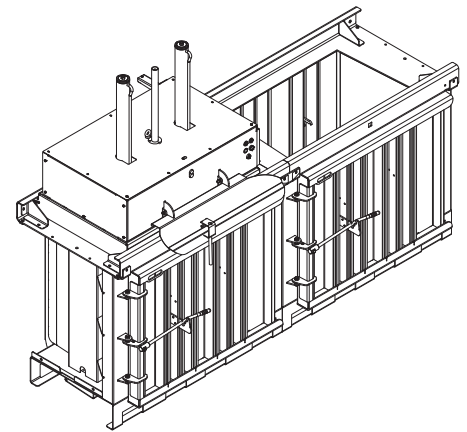
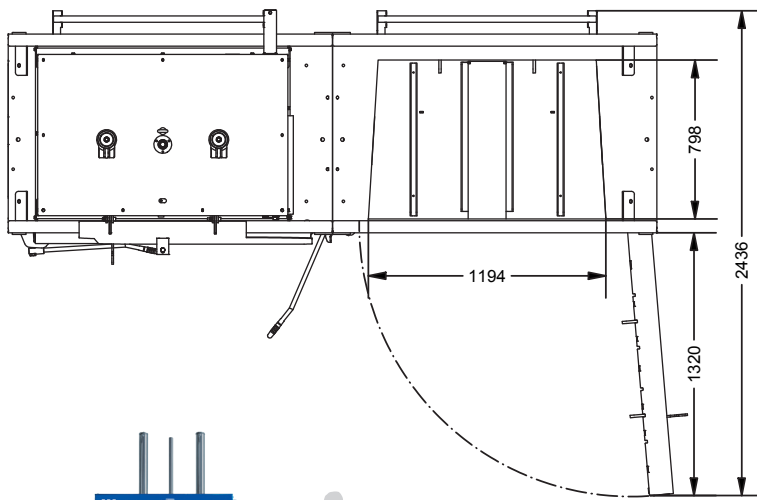
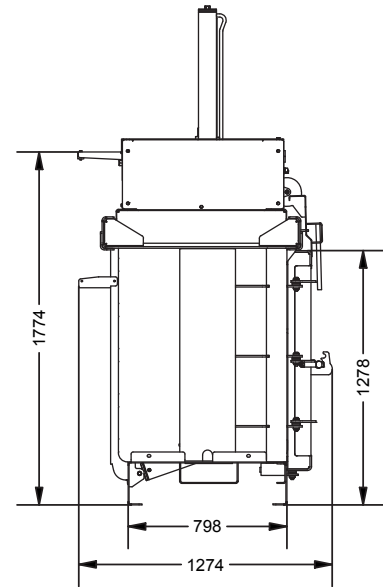
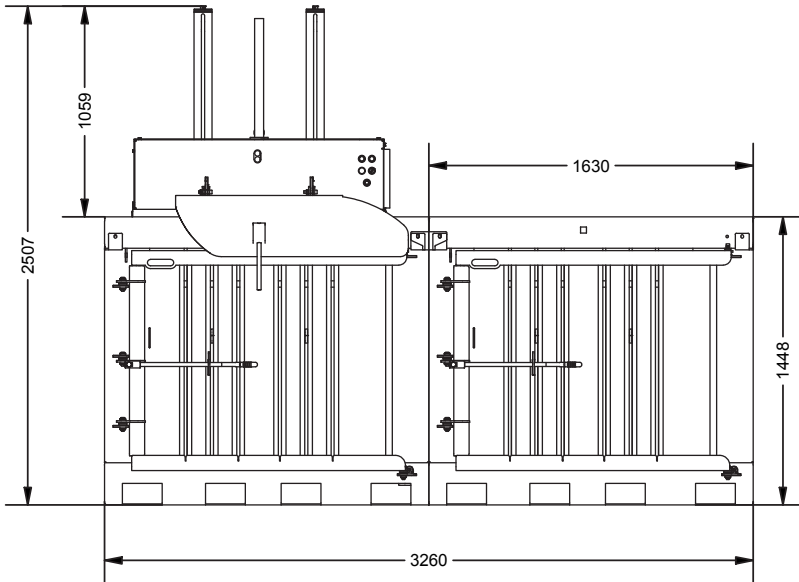

Size Comparison



Bale Weight
Up to 200 Kg



Pressing Force
Up to 16 Ton



Motor
2.2kW 15A



Waste Types
Cardboard, Plastic
Film, Paper, E-Waste,
Cans, LDPE Film ...

