

## LINEAR VIBRATORY WEIGHFILLER LVF-14A/B

The LVF-14A/B linear vibratory filler with one or two heads offers the most suitable solution to weigh and fill **small-sized products** such as **nuts, diced & sliced IQF fruits and vegetables, dried non sticky fruits** and **dry small granular products**.

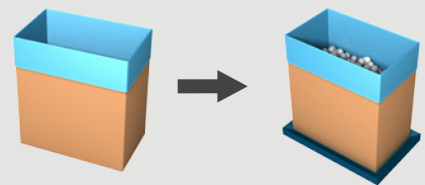

One head vibratory filler  
LVF-14A

COMBINE  
HIGH SPEED &  
ACCURACY

### Easy to use Easy to clean

- Your ideal solution for **easy weigh filling** at high speed up to 15 c/min.
- Hygienic design.
- **Quick & easy cleaning** for minimum down-time.
- Filling in **weigh hopper**.
- Integrated **bag holding device**.

# TECHNICAL SPECIFICATIONS LVF-14A/B

## Easy weigh filling

- Linear filler with 1 vibrating pan feeding the product directly from the infeed funnel to the weigh hopper.
- 5 mm amplitude of feed pan for fast filling into the weigh hopper.
- High accuracy with diverter plate between coarse and fine filling.

## Net filling in weigh hopper

- High line speed, no down time during box transfer.
- Afterfall height for fine filling is low.

## Easy to clean

- Weigh hopper with quick release reduces your cleaning time and cleaning cost.

## For dry bulk products up to 30 x 30 x 30 mm

- Nuts
- Small-sized IQF fruits & vegetables
- Small-sized dried non-sticky fruits
- Dry small granular products like muesli, coffee beans

## Standard equipped with

- Colour touch panel for easy operation



Diverter plate for coarse and fine filling



Filling in weigh hopper

CONTAINER SPECIFICATIONS (For other dimensions, please contact Pattyn)	
Type	Cases, trays, plastic crates...
Range (L x W // D) mm	Min. 300 (L) x 200 (W) // 100 (D) Max. 800 (L) x 500 (W) // 650 (D)
	Outside dimensions
OUTPUT AND CONSUMPTION	
Output	<b>LVF-14A one head vibratory filler</b> Up to 8 c/m (depending on product and weight)  <b>LVF-14B two head vibratory filler</b> Up to 15 c/m (depending on product and weight)
Product diameter size	Max. 30 x 30 x 30 mm
Installed power	LVF-14A: 2 kW LVF-14B: 4 kW
Voltage	3 x 400 V + N + E / 50 Hz
Air supply	6 bar / 1/8" min
Air consumption	4 NL / cycle
Weight	One head filler: 350 kg Two head filler: 800 kg
OPTIONS (More options are available, please contact Pattyn)	
Dimple plate execution	
Heating element to prevent condensation	
Access point for remote support	

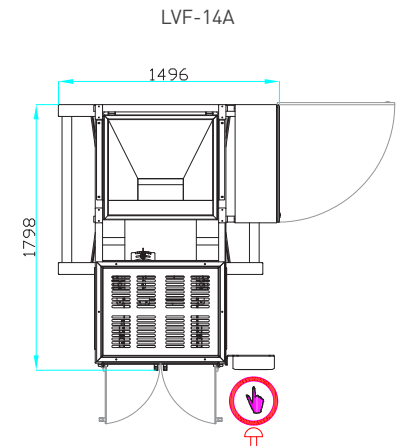

Machine height 3084 mm

Machine height as reference only, depending on case dimensions.

**Accuracy depends on the product and capacity.**  
**For more details or specific requirements, please contact us.**

Pattyn Packing Lines nv  
Industriepark 'Blauwe Toren'  
Hoge Hul 2, 8000 Brugge - Belgium

T +32 (0) 50 450 480  
info@pattyn.com  
www.pattyn.com



The description, pictures and information given have an indicative value. We reserve the right to make changes without notice. Information and content is property of Pattyn. For customised executions please contact Pattyn. LVF-14A/B 2018 - V01

**PATTYN®**

Turnkey solutions for industrial packaging.