

## TECHNICAL DATA SHEET

### INDUSTRIAL WATER CHILLERS – AIR COOLED

#### 4kW to 10kW Cooling Capacity



Thermex Solutions is Australia's largest manufacturer of small specialised industrial water chillers

Industrial process chillers are designed to circulate water to a heat producing process via a water pump. The water brings the heat back to the chiller where the compression cycle cools the water before it is returned to the heat process.

#### Features as standard

- Stainless steel buffer tanks to provide close temperature control and reduce compressor starts
- Sturdy galvanized steel construction to ensure the cabinet provides long life
- High efficiency hermetic scroll compressors
- High efficiency R134a refrigerant with low global warming potential and to ensure operation in even the highest ambient temperatures
- Integrated primary water pumps
- Comprehensive factory acceptance testing before dispatch
- Highly accurate electronic controller
- Hydrophilic coated condensers for high corrosion protection
- Comprehensive 12 months parts and labour warranty
- Pump options to suit any profile
- Stainless steel plate heat exchanger or coaxial evaporators
- Evaporator protection on all models

PERFORMANCE DATA - 380/415V 3 Phase 50Hz					
Model	TC03	TC04	TC07	TC08	TC10
<b>Nominal Cooling capacity – kW</b>	<b>3.3</b>	<b>4.2</b>	<b>7.1</b>	<b>8.2</b>	<b>10.0</b>
Nominal compressor HP	1.5	1.8	2.6	3.0	3.5
<b>Operation in 45°C environment – 10°C Chilled water supply</b>					
Power input - kW	1.6	2.1	3.0	3.5	4.0
Current draw - A	2.8	4.7	6.6	7.2	7.8
Maximum fan power input - kW				0.7	
Maximum fan current draw – A				1.3	
COP	1.8	1.8	2.2	2.3	2.3
<b>Performance in a 35°C Environment – ASHRAE conditions</b>					
Power input	1.2	2.0	2.8	3.2	3.7
Current draw	2.9	4.4	6.0	6.5	7.0
COP	2.1	2.1	2.5	2.5	2.5
IPLV	2.7	2.8	3.4	3.6	3.7

**UNIT INFORMATION**

**Condenser**

Air flow through condenser - M <sup>3</sup> /hr – maximum	7500
Hot air discharge	Vertical
Fan wiring	Delta – 3 phase
Number of fans	1
Condenser construction	7mm rifle bore copper tube – aluminum fin 14 FPI
Air pressure drop across condenser – pa	80
Fan noise rating – dB – 50hz	64
Fan size – mm	500
Fan type - Axial	4 pole – single phase
Condensing capacity control	Head pressure fan speed control
Condenser coating	Nano (blue fin) coated for corrosion protection

**Evaporator**

Pressure drop across evaporator – Pa	50
Evaporator construction	Plate HX
Evaporator material	316 Stainless steel
Fouling factor – evaporator - m <sup>2</sup> C/kW	0.0018
Evaporator protection – standard models	Flow switch and bypass
Chilled water connections	1" FBSP



**GENERAL INFORMATION**

No. refrigeration circuits	1				
No. Of compressors	1				
Application	Standard cooling				
Capacity control	0-100%				
Compressor type	Scroll				
Compressor oil	PVE				
Refrigerant	R134a				
Liquid receiver volume – litres	2.4				
High pressure safety cut out	2450 kPa				
Low pressure safety cut out	70 kPa cut in 170kPa				
Compressor start method	DOL				
General unit construction	Electrostatic epoxy powder coated galvanized sheet metal				
Buffer tank capacity – litres	75L				
TX Valve	Mechanical expansion				
Centre of gravity	50/50 Long axis 50/50 Short axis to the front				
Controller	Electronic				
Buffer tank construction	Stainless steel				
Water fitting – make up water	1/2" MBSP				
Water fittings – drain	1" MBSP				
Overflow fitting	1" MBSP				
Approximate shipping weight – dry	TC03A	TC04A	TC07A	TC08A	TC10A
	140	155	180	180	190
Approximate refrigerant charge – kg	2.3	2.5	3.0	3.1	3.2

**DIMENSIONS**

**TC03 and TC04 Unit**

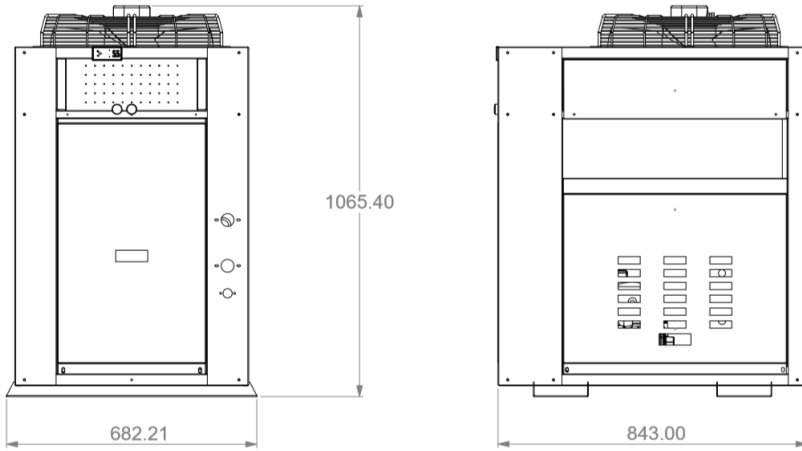

**TC07 to TC10 Unit**

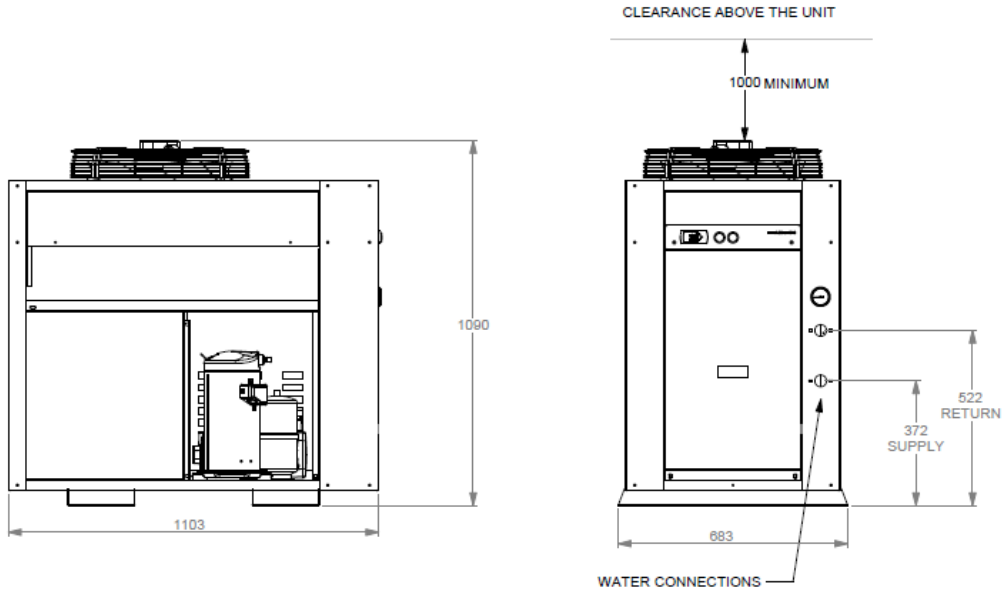

**TC03 to TC10 Closed loop chiller**

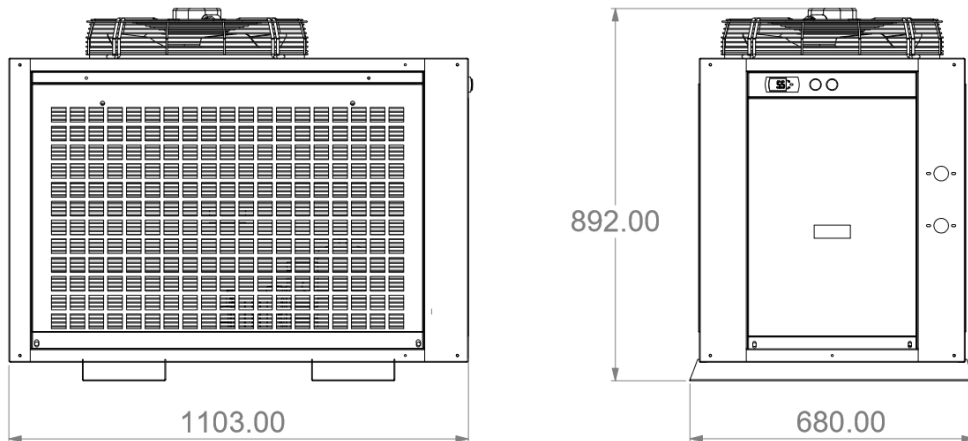

**PUMP PERFORMANCE**

The unit will usually be supplied with a primary circulating pump as standard

THERMEX has the ability to customize the pump for particular applications and these should be specified at the time of order

The unit has an internal water bypass designed to protect the heat exchanger – it should not be closed under any circumstances

The flow/ pressure charts for the pump are shown below

**Pump Data - Models TC03 to TC10**

- RPM 2900
- Approvals - CE,WRAS,ACS,TR,EAC
- Housing – cast iron
- Impeller – Stainless steel 304
- Rated power 0.67 to 1.1 kW
- Rated Hz – 50/60
- Rated voltage 220/ 240
- Rated amps 3.1 to 5.2 amps
- Weight 16kg

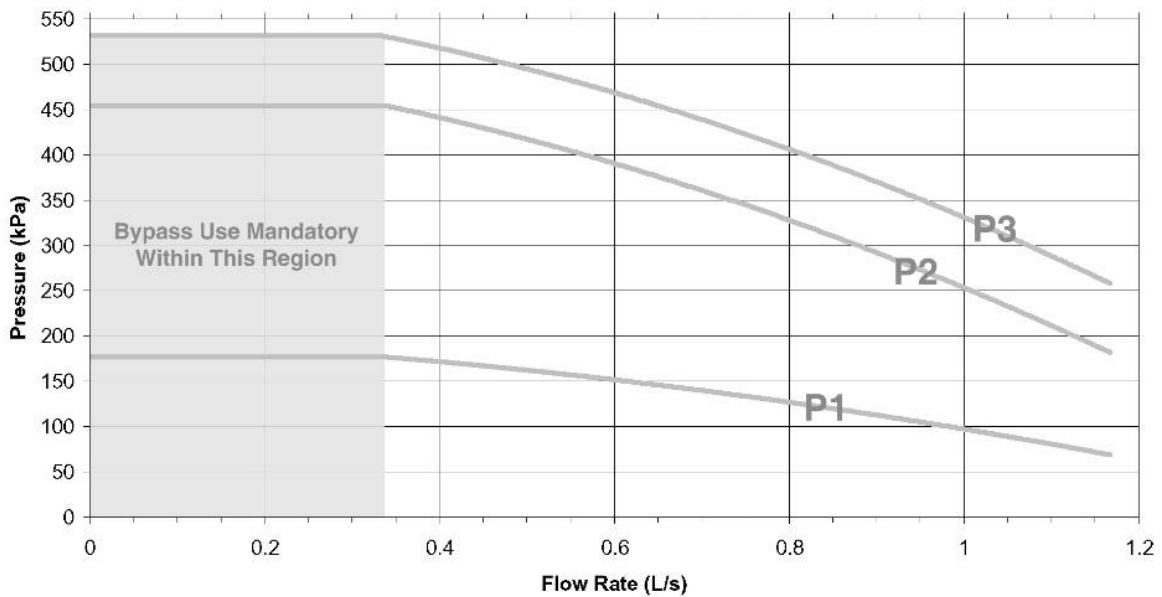

Process chillers are typically not for potable water applications although the chiller can be designed to supply potable water.

All Thermex chillers up to 50kW are supplied with a buffer tank – the buffer tank is an important feature in all chillers and the bigger the better. The buffer tank in a process chiller has many benefits such as

- helping protect the compressor from excessive starts
- preventing thermal spikes impacting on the compressor
- allows closer temperature tolerance to the process
- having stored chilled water to allow a managed shut down of a process should there be a problem with the cooling cycle
- allows for a vented design and prevent the need for a hydronics kit

All Thermex process industrial chillers are supplied with high efficiency scroll compressors supplied by Copeland. The scroll compressor is the latest in compressor technology

All Thermex water chillers use R134a refrigerant – R134a is a contemporary refrigerant with a low global warming potential. R134a refrigerant also has the benefit of being a low-pressure refrigerant gas – this allows Thermex chillers to operate in extreme ambient conditions- up to 52°C. Chinese and European manufactured chillers are rated at 35C ambient condition and are generally supplied with condensers that are not suited to these extreme conditions.

**SELECTING THE CHILLER**

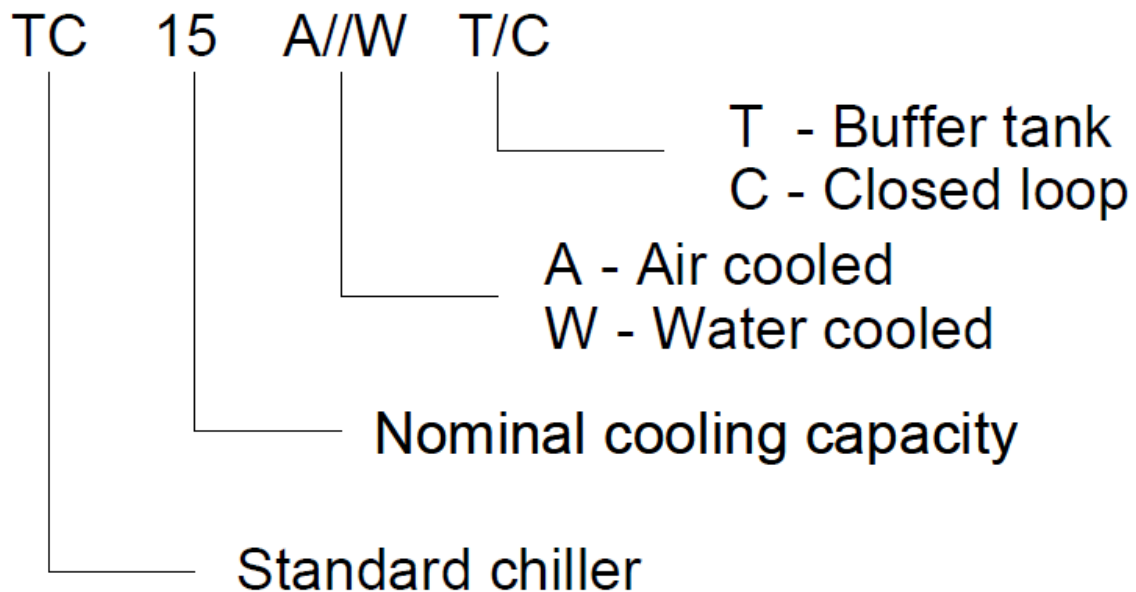

## OPTIONS

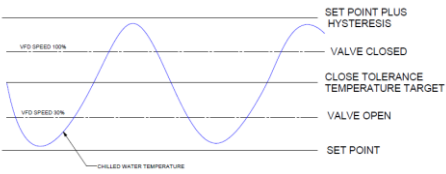
<p><b>Close tolerance (CT)</b></p>	<p>The chiller can be manufactured with either a hot gas bypass valve or a VFD on the compressor for close temperature tolerance. Standard tolerance achievable is <math>\pm 0.5C</math> depending on load conditions</p> <p>The valve acts as to unload the refrigeration effect to the evaporator as the chilled water temperature approached set point.</p> <p>If the compressor is fitted with a VFD this will slow the compressor down as water temperature approaches set point and speed it up as it approached set point plus hysteresis. The software has a PID loop to ensure maximum efficiency and maintain temperature control.</p> 
<p><b>BMS Connectivity</b></p>	<p>The chiller can be connected to the high or low level BMS</p> <p>Low level connectivity will be dry contact for</p> <ul style="list-style-type: none"> <li>- Master run</li> <li>- Master fault</li> </ul> <p>High level connectivity is Modbus, SNMP and Bacnet over Ethernet without the need for a gate way</p>
<p><b>Tandem/ N+1 (T)</b></p>	<p>The chiller can be wired if they are to be installed in a N+1 arrangement so the lead chiller manages the duty cycling of the chillers and controls the chillers if a fault should develop in one of the chillers</p>
<p><b>Potable water supply (I)</b></p>	<p>The chiller can be manufactured to deliver water for potable water application. A typical installation requires the chiller to be connected to the main water and the pressure from the main is used to supply the process.</p> <p>The chiller will have a heat exchanger installed which will cool the mains water to the supply temperature in a single pass</p> <p>If the process does not require water the chillers operation is unaffected</p> <p>This method of construction also allows the chiller to be used to cool water temperatures above 20C</p>
<p><b>Remote Condensers (R)</b></p>	<p>The chiller can be manufactured as a split system. The evaporator can be installed indoors in a plant room for example and the condenser installed outdoors.</p> <p>Typically, the maximum distance between the 2 halves of the chiller is 20 meters – for longer runs contact Thermex’s engineering staff</p>

## OPTIONS

<p><b>High corrosive environments</b></p>	<p>If the chiller is to be installed in an environment with corrosive elements present the chiller can be manufactured in such a way to extend the life of the unit</p> <p>These environments can be</p> <ul style="list-style-type: none"> <li>- Coastal which high levels of salt spray present</li> <li>- Mining with Sulphur present</li> </ul> <p>The coils on the units can be coated to extend their life – the coil will lose efficiency if the bond between the copper and the aluminum starts to break down</p> <p>The units can be constructed with stainless steel cabinets</p> <p>The electrical enclosures are weather proof but if an enclosure is required with a high IP rating this can be offered</p> <p>In the case where flammable gas is present an Ex or ATEX rated unit maybe required</p>
<p><b>Soft starters</b></p>	<p>In installations where the power supply is not robust soft starters can be supplied on the compressors to limit the in-rush current on compressor start up.</p>
<p><b>Redundant pumps</b></p>	<p>The units can be supplied with 2 pumps that duty cycle to share the wear and tear. The software can also start the pump sitting in redundancy if the duty pump develops a fault</p>
<p><b>Pump UPS (U)</b></p>	<p>The electrical box can be supplied with a separate set of terminals to allow an uninterruptable power supply to be wired so the pump will run continuously – this allows the chiller to keep pumping cold water to the process in the event the 3 phase supply develops and issue and allows the process to shut down in a managed way</p>
<p><b>Castors</b></p>	<p>The chiller can be supplied on wheels for ease of re-location</p>
<p><b>High Ambient</b></p>	<p>For installations such as mine sites, especially in remote areas where the temperatures are extreme the chiller can be constructed to be able to handle these extreme temperatures</p>
<p><b>Compressor VSD</b></p>	<p>Variable speed drives – fitted to the compressor to allow turn down in partial load conditions which adds to the operating efficiency of the chiller</p>
<p><b>Redundant pumps</b></p>	<p>The chiller can be supplied with redundant pumps – this allows the chiller to have a healthy chiller in standby in the event one pump fails – the system will also duty cycle the pumps to share the wear and tear</p>



## INSTALLATION

There are certain guidelines that need to be followed to ensure the chiller operates properly and reliably. When considering the purchase of a chiller the site should be prepared so the chiller can be installed and operated reliably

The chiller should also be installed on a level firm surface and should be bolted down to prevent the unit moving. It is not necessary to install the chiller with spring vibration eliminators – waffle pad is sufficient to prevent vibration from the unit

The water pipe work too and from the chiller should be properly insulated to prevent sweating and to ensure the chiller operates as efficiently as possible

There should be adequate space around the chiller to allow proper ventilation of the cooling fans – the chiller should not be installed under an awning or installed indoors if there is not proper ventilation.

**All operational cooling capacity, power consumption and current draw data shown above is based on the chiller operating at the limit of its design and is intended to be an indication only.**

**Each chiller will be individually designed to customer requirements and a detailed product specification will be supplied at time of order including installation instructions and dimensions. The power consumed by the unit and the current it will draw vary depending on how the chiller is constructed. The chillers performance may also vary slightly from the figures above again based on customer requirements.**

**THERMEX Solutions product range is subject to change without notice**

## WARRANTY

- THERMEX Solutions warrants all its products for 12 months from the agreed commissioning date – no later than 30 days from invoicing date.
- The warranty is to the first purchase of the unit
- The warranty covers all parts and labour to rectify the unit
- The warranty is subject to THERMEX Solutions terms and conditions which will be provided at the time of order
- Warranty is subject to Thermex Solutions full terms and conditions

## CONTACT

THERMEX SOLUTIONS  
20/85 ALFRED RD  
CHIPPING NORTON NSW 2170  
AUSTRALIA  
[www.thermex.com.au](http://www.thermex.com.au)

Phone – (02) 9724 2492

Email  
[sales@thermex.com.au](mailto:sales@thermex.com.au)