



YOUR PARTNER WORLDWIDE



SURFACE LAPPING



FLM-400•FLM-600•FLM-900•FLM-1200•FLM-1500



Surface lapping

Lapping is a finishing procedure for fine and finest finishing which achieves high surface quality, extremely high dimensional accuracy and close dimensional tolerances.

Lapping is defined by DIN 8589 and means machining with loose grains distributed in a liquid or paste (the lapping mixture).

The workpieces are normally placed into dressing rings on a lapping plate which must have a level surface so that the workpiece to be lapped also will be flat. The lapping mixture, a compound consisting of a carrier (lapping liquid), a lubricant and abrasive, sits between workpiece and lapping plate. As the workpiece is normally not heated by the lapping process, there is no deformation.

Lapping has become established as the preferred finishing process where non-leaking shutoff is required (e.g. for safety valves, face seals for boiler water feed pumps, compressor valve disk etc.)

EFCO-FLM single plate surface lapping machines are supplied either as table-top machines (FLM-400) or as free standing machines.

The workpieces to be lapped run freely in dressing rings or are placed in appropriate holders (cages) running in the dressing ring. Depending on weight, the workpieces are pressed against the lapping plate using appropriate load plates with a felt being placed between workpiece and weight which equalises different levels.

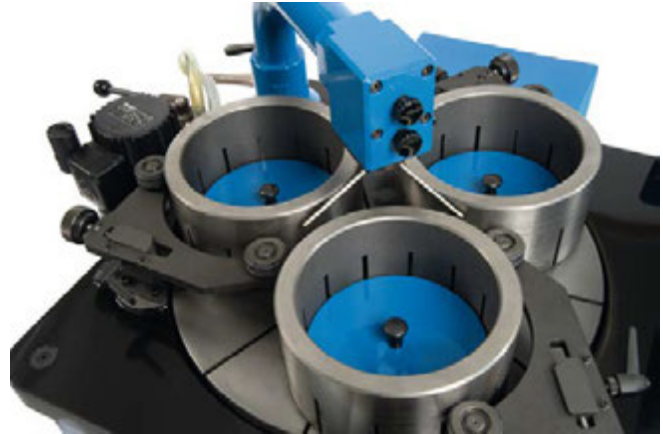

The lapping plate is continually fed with lapping mixture via a pump system.

The lapping mixture pump with stirrer (FLM-1200/FLM-1500) and the lapping mixture tank are designed in such a way that topping up or replacement of the lapping mixture is easy.

Depending on the lapping mixture used as well as material, shape and size of the workpiece, it is, therefore, possible to obtain a surface finish of $R_z = 0.1 \mu\text{m}$ or better.

EFCO FLM Surface Lapping Machines

are excellent for lapping of individual or volume production components.

Worn components, such as valve seats, mechanical shaft seals, disks, vanes, gears, can be re-lapped in repair workshops and at refurbishment companies.



EFCO FLM-400



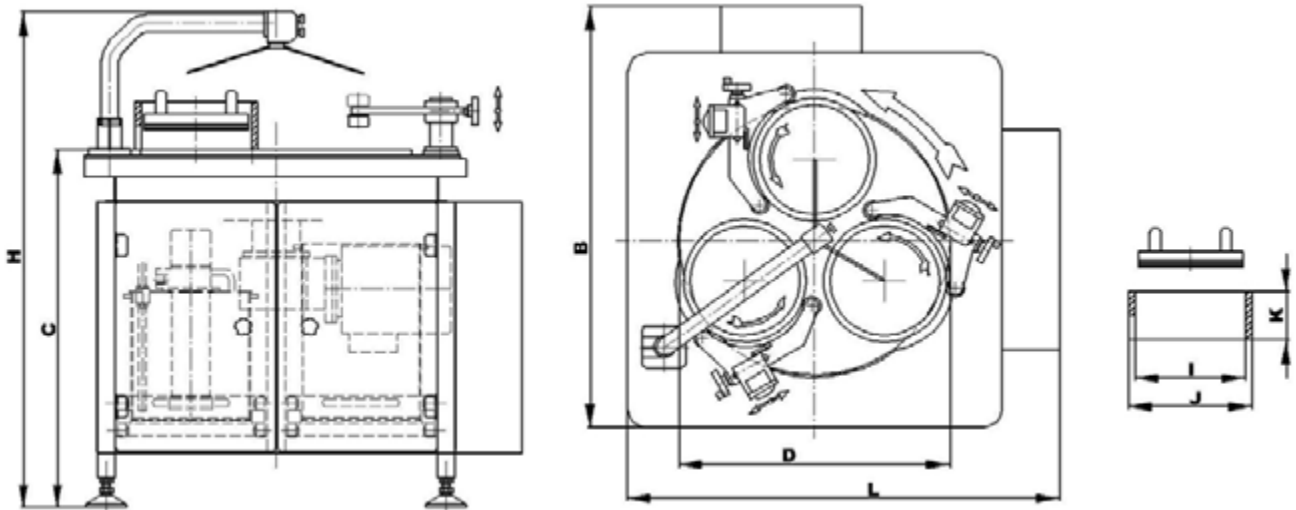

	FLM					
	400	600	900	1200	1500	
Machine dimension						
Machine height "H" [mm/inch]	520 (20.5")	1175 (46.3")	1330 (52.4")	1380 (54.3")	1410 (55.5")	
Width "B" [mm/inch]	780 (30.7")	1040 (40.9")	1260 (49.6")	1560 (61.4")	1900 (74.8")	
Width "L" [mm/inch]	890 (35")	1030 (40.6")	1430 (56.3")	1870 (73.6")	2145 (84.4")	
Top edge of lapping wheel "C" [mm/inch]	295 (11.6")	820 (32.3")	950(37.4")	950 (37.4")	950 (37.4")	
Ø Lapping wheel "D" [mm/inch]	405 (15.9")	615 (24.2")	915 (36")	1215 (47.8")	1515 (59.6")	
Dressing ring						
Number	3					
Inner-Ø "I" [mm/inch]	152 (6")	250 (9.8")	380 (15")	500 (19.7")	625 (24.6")	
Outer-Ø "J" [mm/inch]	185 (7.3")	280 (11")	420 (16.5")	550 (21.7")	690 (27.2")	
Height "K" [mm/inch]	90 (3.5")	110 (4.3")	135 (5.3")	140 (5.5")	14 (5.5")	
Max. component-Ø [mm/inch]	120 (4.7")	220 (8.7")	350 (13.8")	470 (18.5")	600 (23.6")	
Data and Weight						
Lapping wheel speed [rpm]	8 – 70	8 – 74	8 – 50	8 – 44	8 – 34	
Drive motor output [kW]	0,55	3	7,5	11	11	
Lapping material tank capacity [l]	4	15	33	33	33	
Power supply [V / Hz]	230 / 50	400 / 50				
Noise emission [db(A)]	< 75					
max. component weight [kg]	single	10	50	100	150	150
	total	30	150	300	450	450
Net weight [kg]	130	500	1040	2220	2820	

Testing of workpieces

The following are required to precisely check the flatness of workpieces:

- Interference lamp
- Polishing table with polishing paper
- Plane face lenses Ø25-300 (Ø0.9"-11.8")



Our range includes a surface roughness tester to precisely check the roughness of workpieces.

Specifications

Measurement range: Ra,Rq: 0.01-100µm
Rz,Ry: 0.02-350µm
Pc: 2.5/cm-5000/cm

Measured sections: 0.25 mm, 0.8 mm, 2.5 mm

Parameters: Ra, Ry, Rz, Rq, S, Sm, Pc, r3z, mr, rt, Rp, Rk, Rvk, Mr1, Mr2, A1, A2

Probe tip: Diamond (tip radius 2 µm)

Power supply: via mains adapter or built-in rechargeable battery



Consumables

The lapping mixture for surface lapping machines consists of abrasive mixed with lapping liquid (ratio: 150-220g abrasive to 1 litre of lapping liquid).

Abrasive

- Silicon carbide (SiC) - for alloyed and hardened steels, stellites, glass, porcelain etc.
- Aluminium oxide (Al₂O₃) – for copper, bronze, coal, cast iron, silicon etc.
- Boron carbide - for carbide, ceramics
- Diamond - for carbide, ceramics

The abrasive can be supplied in various grain sizes.

The most frequently used lapping abrasive is silicon carbide with grain size 600 (coarse) or 800 (finer).

Our ECO CUT HO-74 lapping liquid, a multi-purpose oil of average viscosity, is suitable for mixing with all types of lapping abrasives.

Subject to technical change.

EFCO Maschinenbau GmbH – Valve repair and testing equipment

Otto-Brenner-Straße 5 – 7 • D - 52353 Düren • Phone: +49-(0)2421-989-0 • Fax: +49-(0)2421-86260

sales@efco-dueren.de • www.efco-dueren.com

Agencies in many countries

05/2015 – 05