

OPERATOR'S MANUAL

INCLUDING: OPERATION, INSTRUCTION, INSTALLATION, MAINTENANCE AND PARTSBOOK

IMPORTANT: READ THIS MANUAL CAREFULLY BEFORE INSTALLING, OPERATING OR SERVICING THIS TOOL.

HORIZONTAL HYDRAULIC BREAKING SAW "HKM-I-H"

TOOL DATA

MODEL: HKM-I-H

ASSEMBLY No: 6622010



TYPE: AIR/HYDRAULIC OPERATED

NET WEIGHT: 18 LBS (8.2 KG)



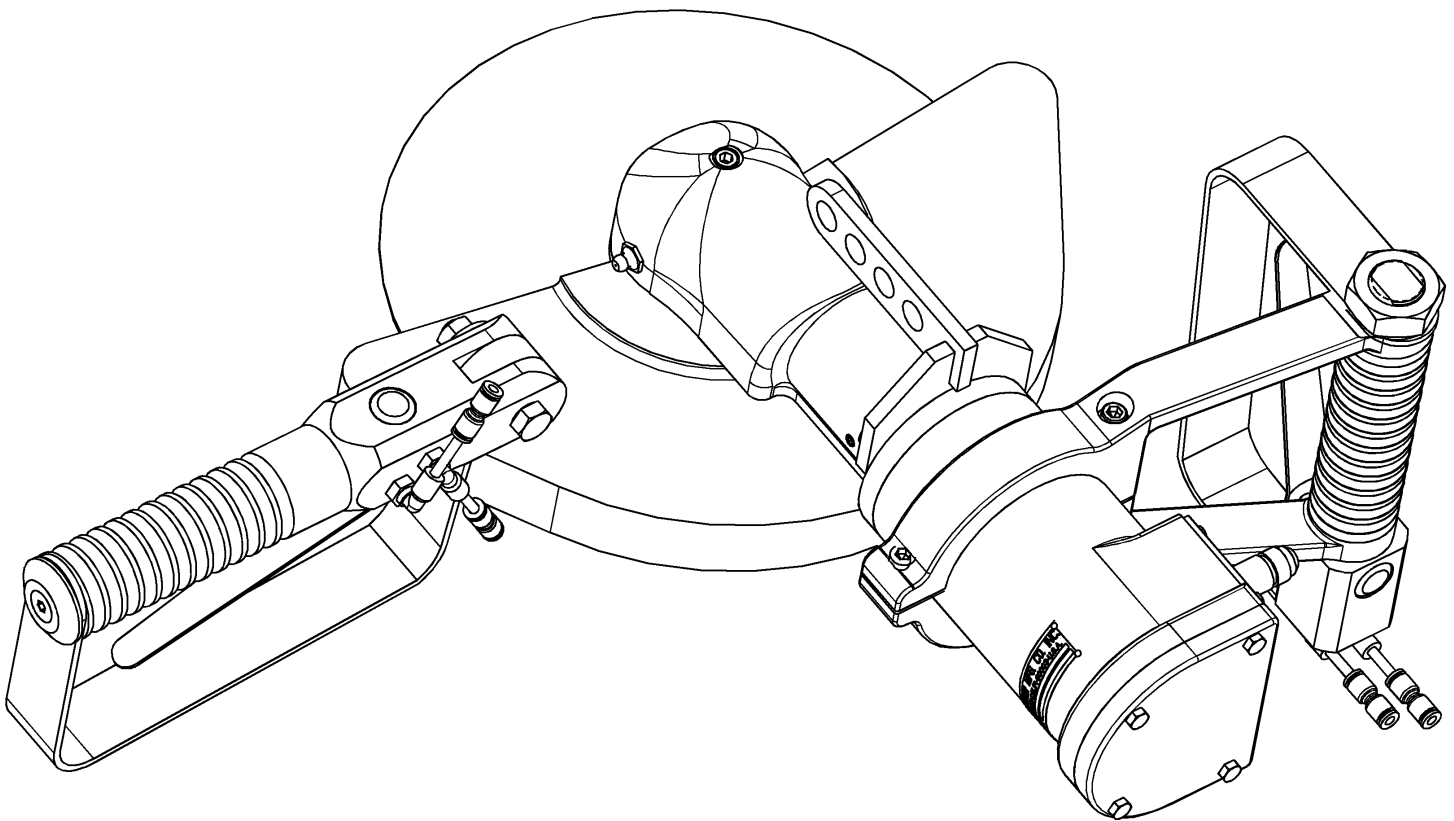











HYDRAULIC PRESSURE: 1500 P.S.I. MAXIMUM

INLET AIR PRESSURE: 90 P.S.I. (6-7 BARS)



 WARNING	= Hazards or unsafe practices which could result in severe personal injury, death or substantial property damage.
 CAUTION	= Hazards or unsafe practices which could result in minor personal injury, product or property damage.
 NOTICE	= Important installation, operation or maintenance information.

OPERATING AND SAFETY INSTRUCTIONS

-  **WARNING** DO NOT OPERATE THIS TOOL UNTIL YOU HAVE READ AND UNDERSTOOD THE SAFETY INSTRUCTIONS AND OPERATING MANUALS.
-  **WARNING** DO NOT OPERATE THIS TOOL UNTIL YOU HAVE RECEIVED TRAINING IN THE HANDLING, OPERATION AND USE OF THIS TOOL.
-  **WARNING** STOP USING A MALFUNCTIONING OR DEFECTIVE TOOL IMMEDIATELY. REPORT ANY PROBLEMS OR DEFECTS TO YOUR SUPERVISOR FOR REMOVAL OF THE TOOL FROM SERVICE.
-  **WARNING** DO NOT ATTEMPT TO REPAIR THE TOOL YOURSELF.
-  **WARNING** DO NOT ALLOW UNAUTHORIZED PERSONS TO USE TOOL.
-  **WARNING** REMOVE AND DISCONNECT POWER FROM THE TOOL WHEN TOOL IS LEFT UNATTENDED OR IS NOT IN USE.
-  **WARNING** NEVER TIE DOWN, BYPASS, ALTER OR MODIFY THE ACTIVATING SWITCHES OR TRIGGERS OF THIS TOOL.
-  **WARNING** NEVER MAKE ALTERATIONS OR MODIFICATIONS TO THIS TOOL.
-  **WARNING** BE CONSTANTLY AWARE AND ALERT FOR UNSAFE CONDITIONS AND REPORT THEM IMMEDIATELY TO YOUR SUPERVISOR.
-  **WARNING** NEVER PLACE YOUR HAND OR ANY PART OF YOUR BODY IN THE CUTTING PATH OF THE TOOL.
-  **WARNING** NEVER ALLOW ANYONE ELSE TO PLACE THEIR HANDS OR ANY PART OF THEIR BODY IN THE CUTTING PATH OF THE TOOL.
-  **WARNING** DO NOT ACTIVATE CONTROL SWITCHES OR TRIGGERS OF THIS TOOL UNLESS YOU INTEND TO TEST OR OPERATE THIS TOOL.
-  **WARNING** DO NOT USE THIS TOOL FOR ANY PURPOSE OTHER THAN IT'S INTENDED PURPOSE.
-  **CAUTION** WHEN OPERATING THIS TOOL WEAR THE PROTECTIVE GEAR AND SAFETY EQUIPMENT SUPPLIED TO YOU.
-  **WARNING** THE NOISE EMISSION (SOUND PRESSURE LEVEL) AT THE WORKSTATION MAY EXCEED 80 dB (A). EAR AND SOUND PROTECTION GEAR IS REQUIRED.

OPERATING INSTRUCTIONS

⚠ WARNING ONLY TRAINED PERSONNEL ARE TO OPERATE THIS TOOL.

1. TO ENSURE TOOL IS OPERATING PROPERLY, PERFORM FOLLOWING STEPS AT START OF EACH SHIFT:
 - MAKE SURE TOOL MOVES UP AND DOWN FREELY WHILE HANGING FROM BALANCER OVERHEAD.
 - WITH POWER TO TOOL TURNED ON, TEST TRIGGER FOR PROPER OPERATION.
 - DEPRESS EACH TRIGGER SEPARATELY. TOOL SHOULD NOT ACTIVATE. DEPRESS BOTH TRIGGERS. TOOL SHOULD ACTIVATE.
 - IF TOOL HAS "ANTI-TIE DOWN" OPTION, BOTH TRIGGERS MUST BE DEPRESSED SIMULTANEOUSLY FOR TOOL TO ACTIVATE.
2. TO PERFORM WORK, HOLD TOOL FIRMLY AT BOTH HANDLES. SQUEEZE TRIGGERS TO ACTIVATE TOOL.
3. POSITION TOOL AND PERFORM CUTTING OPERATION.

MAINTENANCE

⚠ WARNING ONLY TRAINED AND QUALIFIED PERSONNEL ARE TO PERFORM MAINTENANCE AND SERVICE TO THIS TOOL.

1. MAKE ALL NECESSARY LINE CONNECTIONS TO THE TOOL.
2. AN AIR FILTER-REGULATOR-LUBRICATOR (PART NO. 7200030) MUST BE INSTALLED IN AIR SUPPLY FOR EACH TOOL.
3. FILL LUBRICATOR WITH KENTMASTER AIR MIST OIL (PART NO. 7903050). SET DRIP RATE ACCORDING TO INSTRUCTIONS SUPPLIED. TURN ADJUSTMENT ON SIGHT FEED DOME TO INCREASE/DECREASE OIL DELIVERY. MONITOR THE DEVICE BEING LUBRICATED AND READJUST IF NEEDED.
4. TOOL REQUIRES 90 P.S.I. AIR PRESSURE.

SERVICE

1. KEEP GOOD RECORDS OF ALL SERVICE ACTIVITY AND INCLUDE TOOL IN PREVENTIVE MAINTENANCE PROGRAM.
2. USE ONLY GENUINE KENTMASTER REPLACEMENT PARTS TO ASSURE PROPER PERFORMANCE OF TOOL.
3. CONTACT THE KENTMASTER SUPPLIER NEAREST YOU FOR PARTS AND CUSTOMER SERVICE INFORMATION.

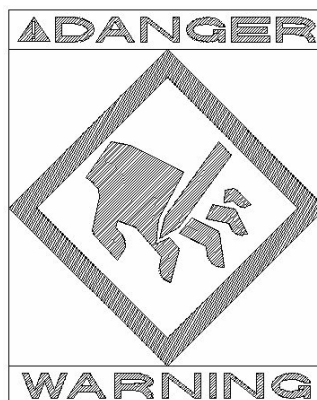

BLADE REMOVAL AND CLEANING.

⚠ WARNING ALWAYS DISCONNECT POWER SUPPLY FROM TOOL BEFORE INSTALLING OR REMOVING BLADE FROM TOOL.

⚠ WARNING ALWAYS WEAR WIRE MESH GLOVES WHEN INSTALLING OR REMOVING BLADE FROM TOOL.

1. REMOVE BOLT, WASHER AND FLANGE (ITEM NO. 1, 2 AND 3, FIG. NO. 1).
2. REMOVE BLADE (ITEM NO. 4, FIG. NO. 1).
3. CLEAN ALL PARTS REMOVED WITH SOAP AND WATER.
4. SHARPEN OR REPLACE BLADES WHEN NECESSARY.
5. REASSEMBLE IN REVERSE ORDER.

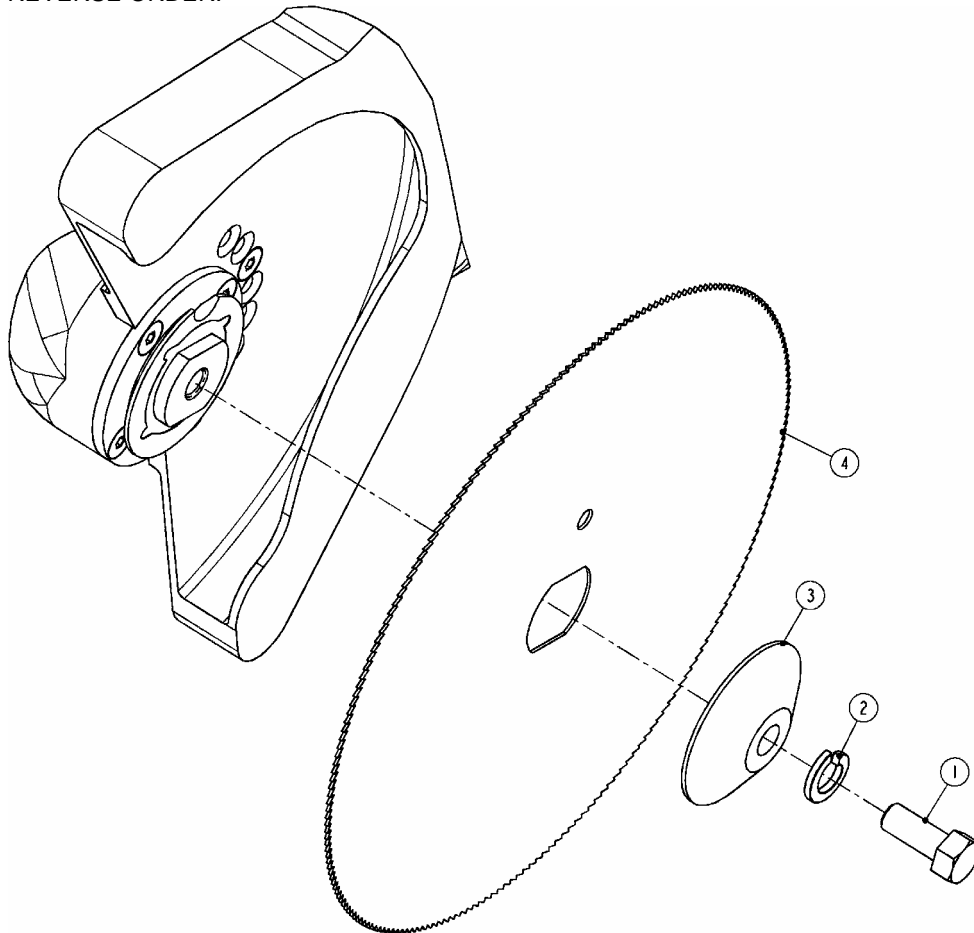

Figure 1 MODEL HKM-I-H – BLADE REPLACEMENT

PARTS BOOK

HKM-I-H

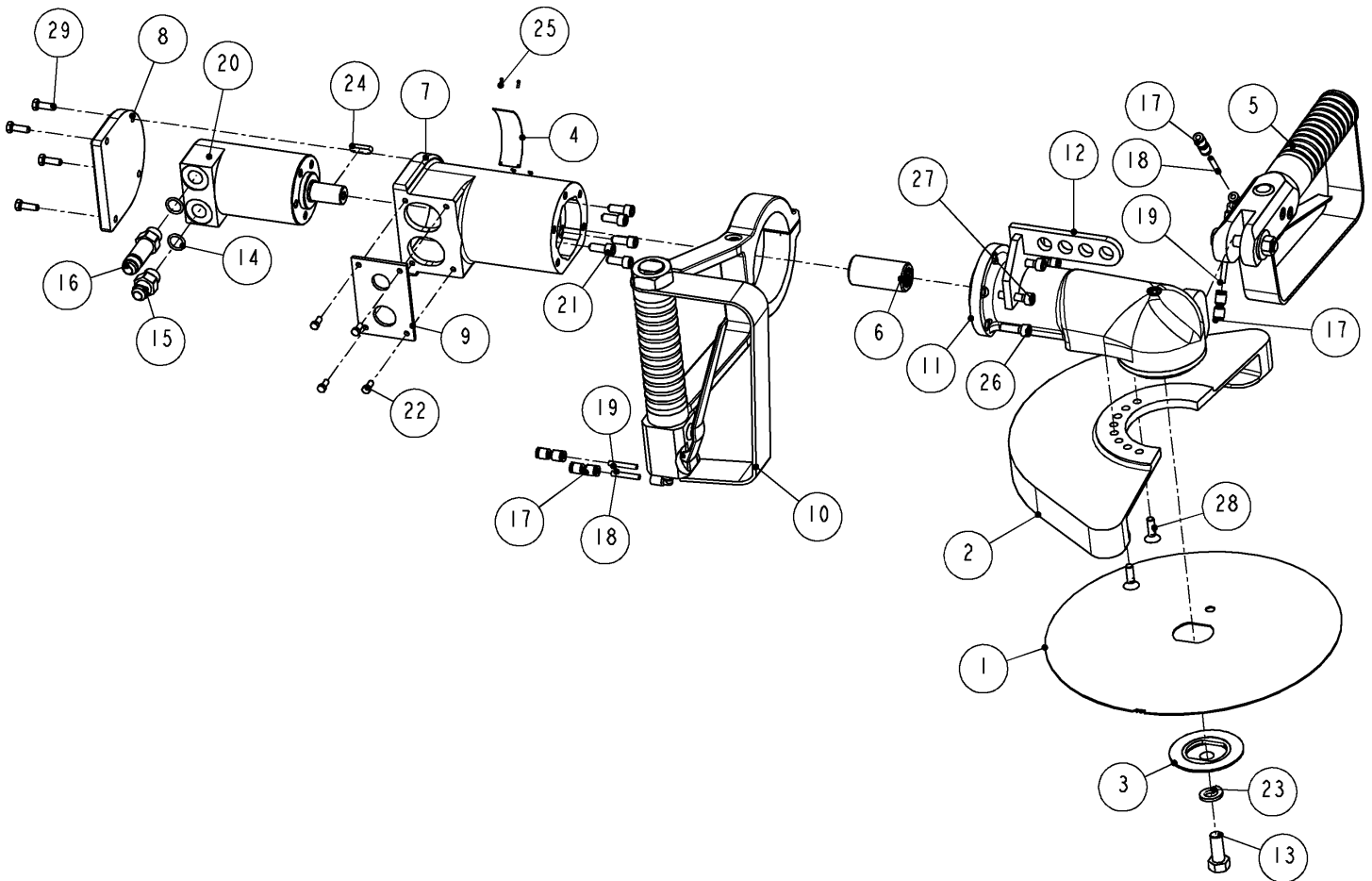

Figure 2 MODEL "HKM-I-H" – MAIN ASSEMBLY

6622010: HKM-I-H HORIZONTAL BREAKING SAW, HYDRAULIC			
ITEM	PART #	DESCRIPTION	QTY
1	4000320	10" SAW BLADE, 40 TEETH - STANDARD	1
	4000060	10" SAW BLADE, 220 TEETH	1
	4000200	9" SAW BLADE, 120 TEETH	1
2	6622112	GUARD FOR 9" AND 10" BLADE	1
3	1300830	FLANGE - SAW BLADE	1
4	6211690	NAME PLATE	1
5	6600530	AIR HANDLE	1
6	6620280	COUPLING	1
7	6620360	MOTOR SHELL	1
8	6620371	BRACKET, HANDLE	1
9	6620410	COVER PLATE	1
10	6620700	FRONT HANDLE ASSEMBLY	1
11	6622190	NOSE ASSEMBLY	1
12	6622210	HANGER	1
13	6623280	SCREW	1
14	7009040	O-RING	2
15	7009550	STRAIGHT CONNECTOR	1
16	7009740	STRAIGHT CONNECTOR	1
17	7037860	UNION	4
18	7300710	RED AIR TUBE	1
19	7300720	GREEN AIR TUBE	1
20	7805050	HYDRAULIC MOTOR	1
21	8212050	SCREW	5
22	8408030	SCREW	4
23	8506170	WASHER	1
24	8606550	KEY	1
25	8640030	DRIVE SCREW	4
26	9211060	SCREW	2
27	9211080	SCREW	3
28	9241060	SCREW	2
29	9409050	SCREW	4

MOTOR DISASSEMBLY AND REASSEMBLY

1. REMOVE 5 SCREWS (#26 AND #27, FIG. 2) BETWEEN NOSE (#11) AND MOTOR SHELL (#7)
2. DISCONNECT 2 CONNECTORS (#15 AND #16).
3. REMOVE SCREWS (#21 AND #29) AND HANDLE BRACKET (#8)
4. SLIDE OUT MOTOR (20), REMOVE COUPLING (#6) AND KEY (#24) ON MOTOR SIDE
5. CLEAN AND LUBRICATE ALL PARTS PRIOR TO REASSEMBLY. REASSEMBLE PARTS IN REVERSE ORDER
6. **INSPECT O-RINGS (#14) FOR ANY CUTS AO FLAT SPOTS. (THESE CAN CAUSE LEAKS) REPLACE PARTS AS NEEDED.**

Figure 3 BOM FOR MODEL "HKM-I-H"

HANDLES

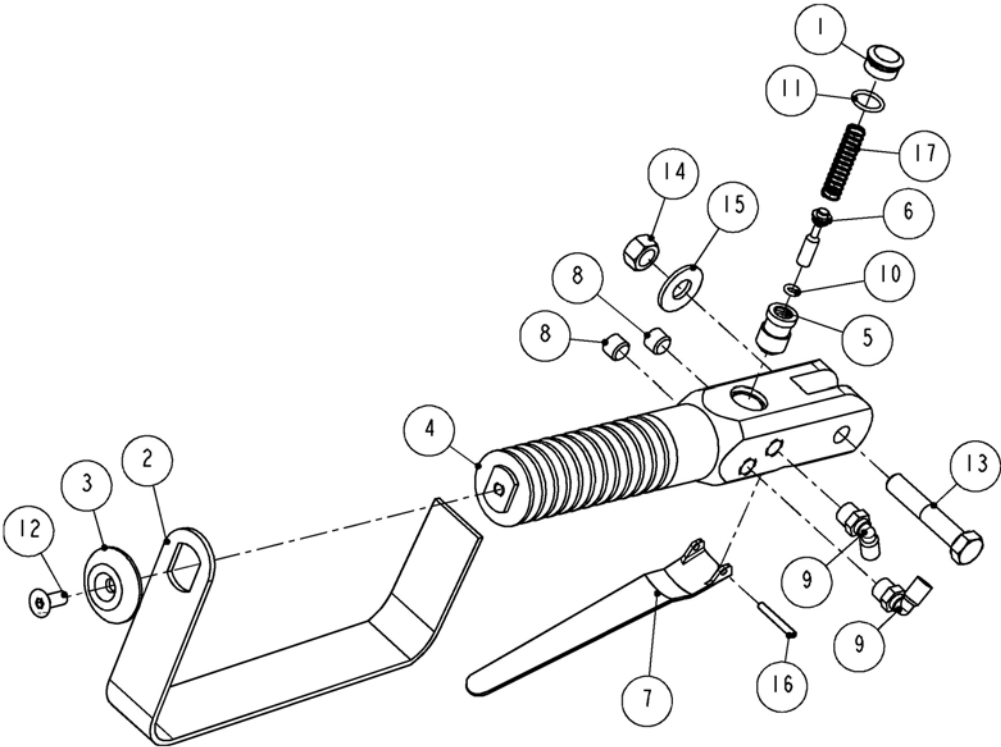

6600530: AIR HANDLE			
ITEM	PART #	DESCRIPTION	QTY
1	6300770	VALVE PLUG	1
2	6541690	GUARD	1
3	6541720	RETAINER	1
4	6600340	HANDLE	1
5	6600350	BUSHING	1
6	6600360	VALVE STEM	1
7	6600500	LEVER	1
8	7000010	PLUG	2
9	7036510	ELBOW	2
10	7680080	O-RING	1
11	7680140	O-RING	1
12	8241050	SCREW	1
13	8415160	SCREW	1
14	8500150	NUT	1
15	8505160	WASHER	1
16	8620080	PIN	1
17	8890010	SPRING	1

Figure 4 6600530: AIR HANDLE

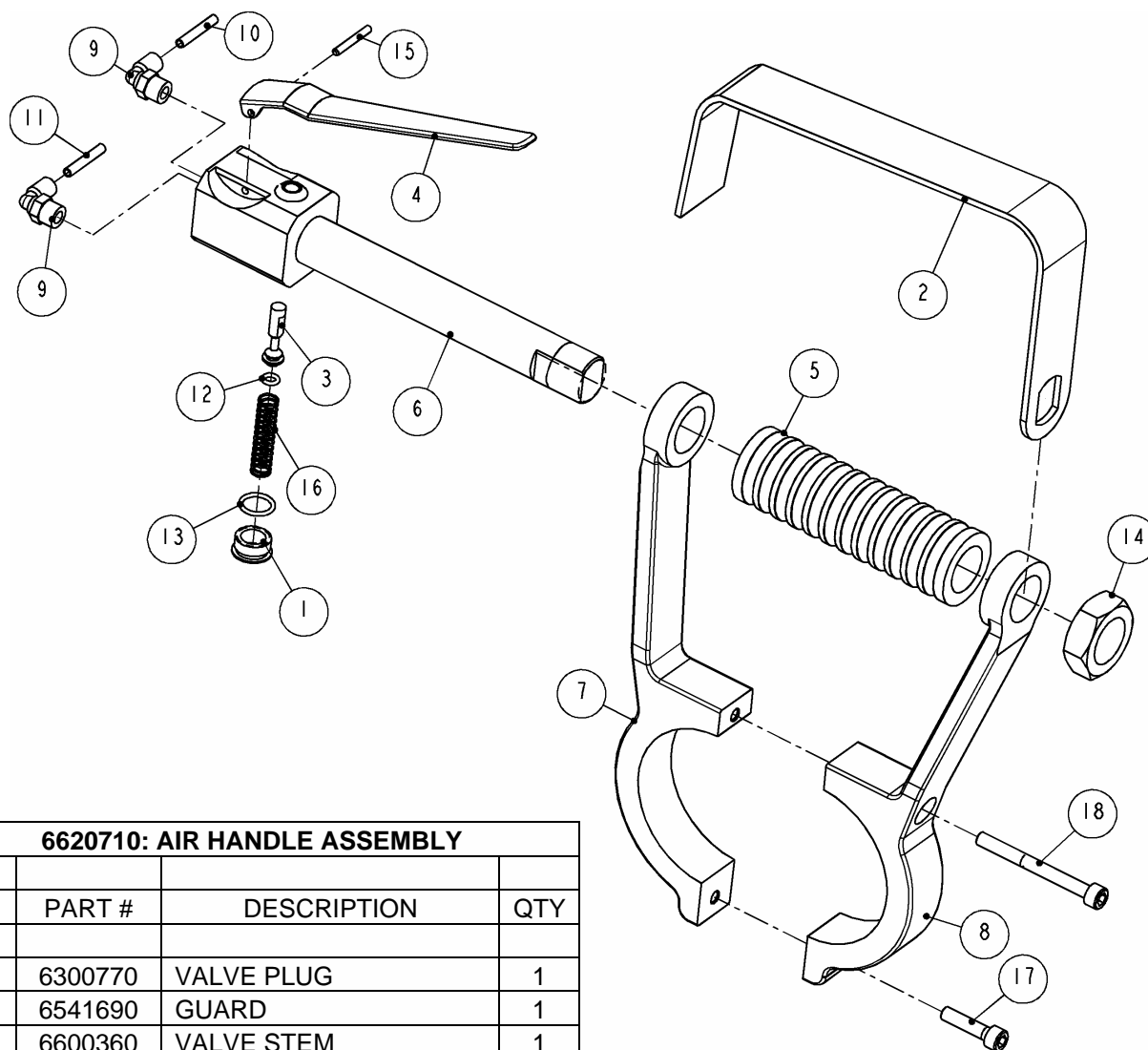

6620710: AIR HANDLE ASSEMBLY			
ITEM	PART #	DESCRIPTION	QTY
1	6300770	VALVE PLUG	1
2	6541690	GUARD	1
3	6600360	VALVE STEM	1
4	6600500	LEVER	1
5	6620350	SLEEVE	1
6	6620400	AIR HANDLE	1
7	6622131	HANDLE BAR - R.H.	1
8	6622141	HANDLE BAR - L.H.	1
9	7036510	ELBOW	2
10	7300710	RED AIR TUBE	1
11	7300720	GREEN AIR TUBE	1
12	7680080	O-RING	1
13	7680140	O-RING	1
14	8500580	NUT	1
15	8620080	PIN	1
16	8890010	SPRING	1
17	9211080	SCREW	1
18	9211200	SCREW	1

Figure 5 6620710: AIR HANDLE, ASSEMBLY

NOSE ASSEMBLY

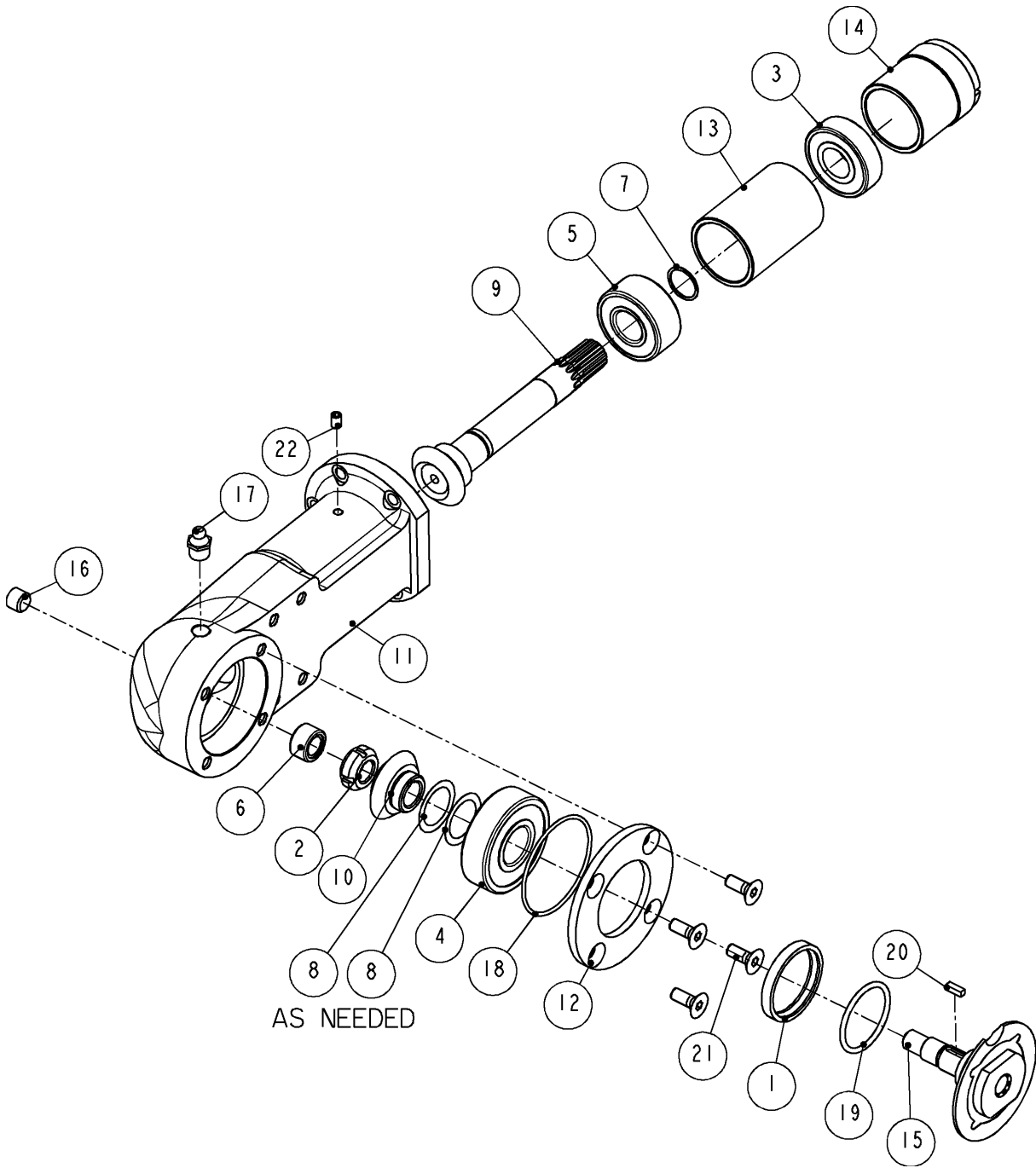

Figure 6 6622190: NOSE ASSEMBLY

6622190: NOSE ASSEMBLY			
ITEM	PART #	DESCRIPTION	QTY
1	1301620	RING	1
2	3001120	BEARING LOCKNUT	1
3	3204030	BEARING	1
4	3304040	BEARING	1
5	3524030	BEARING	1
6	3705320	BEARING	1
7	5620660	RETAINING RING	1
8	6201210	SHIM WASHER	REQ.
9	6620200	BEVEL PINION	1
10	6620210	BEVEL GEAR	1
11	6620230	NOSE	1
12	6620240	FLANGE	1
13	6620260	SPACER	1
14	6620270	RETAINER	1
15	6624010	MANDREL - R.H.	1
16	7000010	PLUG	1
17	7018200	LUBE FITTING	1
18	7680330	O-RING	1
19	7701250	O-RING	1
20	8602020	SQUARE KEY	1
21	9241050	SCREW	4
22	9311030	SET SCREW	1

SAW MANDREL DISASSEMBLY

1. REMOVE SAW BLADE. (SEE FIGURE 1 – BLADE REPLACEMENT)
2. REMOVE BLADE GUARD
3. REMOVE FOUR SCREWS (ITEM 21, FIG. 6)
4. REMOVE PLUG (ITEM 16, FIG. 6). WITH ACENTER PUNCH INSERTED THRU HOLE PLUGGED WITH PLUG, PRESS OUT MANDREL (ITEM 15, FIG. 6) AND ALL OTHER INTERNAL PARTS.
5. LOOSEN SCREW (ITEM 22, FIG. 6)
6. USING HOLDER TOOL (KM #4501850 – OPTIONAL), REMOVE RETAINER (ITEM 14, FIG. 6)
7. THRU BORE THAT HOUSES MANDREL, PUSH PINION (ITEM 9, FIG. 6) OUT BACK.

SAW MANDREL REASSEMBLY

1. CLEAN AND LUBRICATE ALL PARTS PRIOR TO ASSEMBLY
2. SHARPEN OR REPLACBLADE AS NEEDED
3. REASSEMBLE PARTS IN REVERSE ORDER
4. **FILL WITH GREASE (KENTMASTER GREASE – 7903070) AT FITTING (ITEM 17, FIG. 6) BEFORE USING TOOL**

Figure 7 BOM FOR 6622190: NOSE ASSEMBLY

KENTMASTER MFG. CO., INC. 1801 SOUTH MOUNTAIN AVE., MONROVIA, CALIFORNIA 91016 UNITED STATES OF AMERICA
 ☎ TELEPHONE: (626) 359-8888 FAX: (626) 303-5151

TUBING DIAGRAM

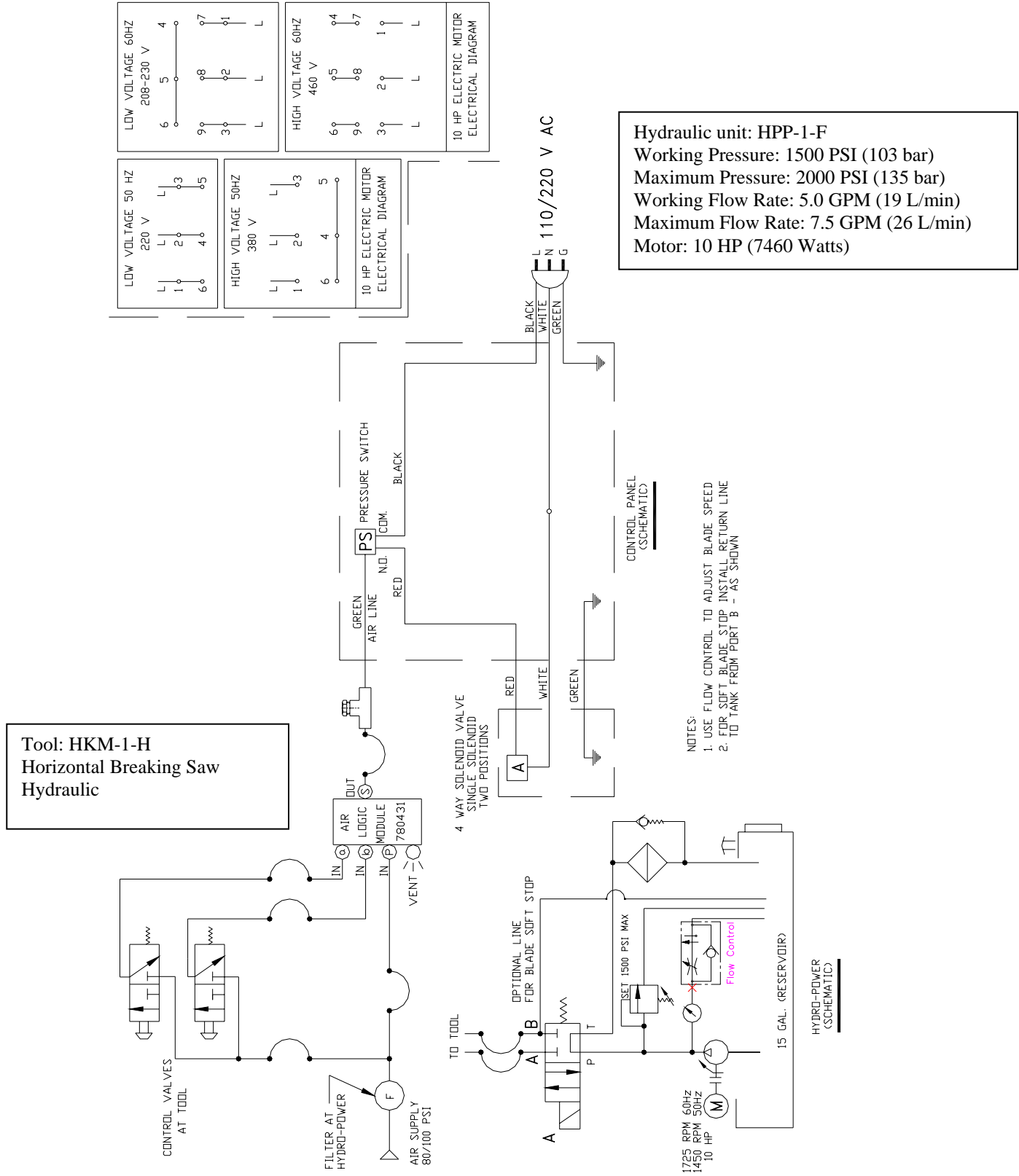

Figure 8 HKM-I-H WITH HPP-I-F DIAGRAM WITH ANTI-TIE DOWN

TOOL ADJUSTMENTS:

Blade Speed:

Use flow control valve on the hydraulic unit to adjust blade speed.
Recommended speed is 1650 RPM (pre-set).

Pressure:

Hydraulic unit is shipped with 1500 PSI setup.

To adjust pressure:

1. Disconnect hoses from subplate (ports A and B) and plug the ports. Activate the pump and use pressure relief cartridge (Part #780478) on subplate to adjust pressure.

Blade soft stop:

Kentmaster recommends “Soft stop” return line – hydraulic oil return line from port B to tank – It allows blade more time to stop after triggers are released .

[ENGLISH]

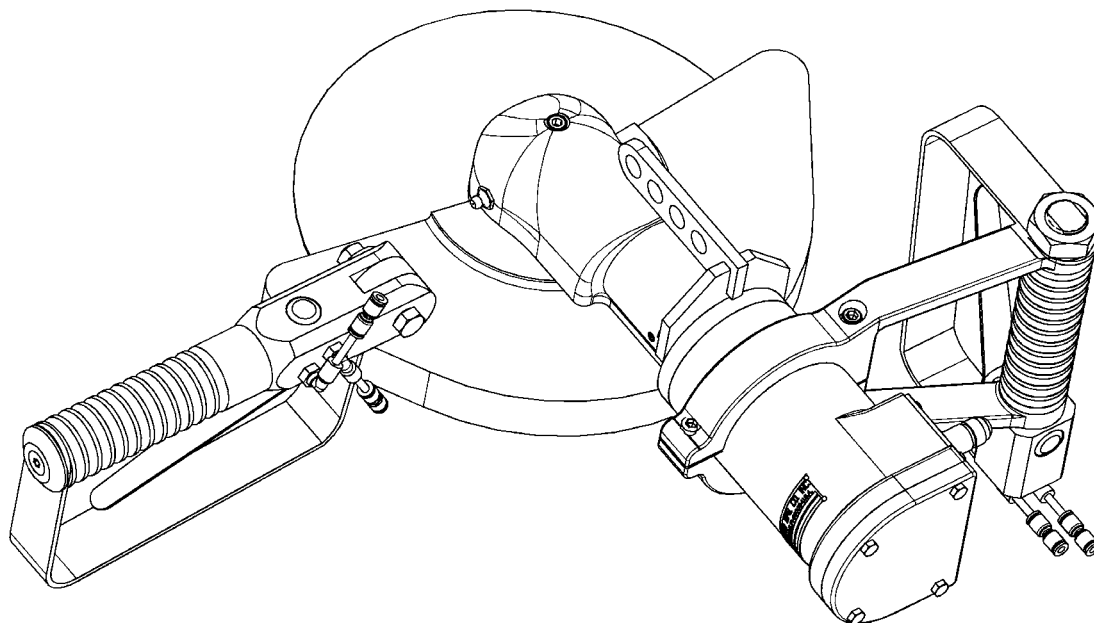
GENERAL INFORMATION

MODEL
“HKM-I-H” HYDRAULIC BREAKING SAW

SERVICE CENTERS

KENTMASTER LTD. (U.K)
 16 AVONBANK INDUSTRIAL CENTRE
 WEST TOWN ROAD
 AVONMOUTH - BRISTOL BS11 9DE
 UNITED KINGDOM

☎ **TELEPHONE: ++ 44- (0) 117- 9235035**
FAX: ++ 44- (0) 117- 9829010

KENTMASTER MFG. CO., INC.
 1801 SOUTH MOUNTAIN AVE.
 MONROVIA, CALIFORNIA 91016
 UNITED STATES OF AMERICA

☎ **TELEPHONE: (626) 359-8888**
FAX: (626) 303-5151

NOTICE TO EMPLOYER AND PURCHASER OF TOOL
NOTICE TO SAFETY DIRECTOR

You have purchased a powerful tool that, if misused, can cause severe injury and harm to your employees. You must instruct your employees in the safe and proper use of this tool and to follow the safety procedures and instructions that have been supplied by the manufacturer of this tool. Please follow the following instructions.

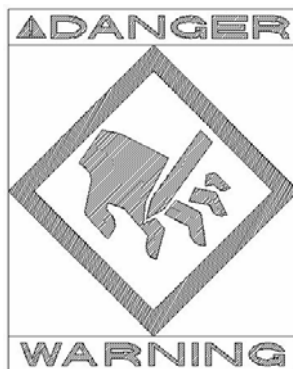

1. Instruct tool operators to test the tool each day before using it to be sure it does not malfunction. Remove and repair any tool that malfunctions.
2. Instruct tool operators to immediately stop using a tool that malfunctions or is defective.
3. Instruct personnel to immediately remove all tools that malfunction. Be sure to disconnect tool from power supply.
4. Instruct all personnel to stay clear of tool, and not to stand or walk in front of, or next to tool when in use.
5. Point out to all personnel the dangers related to the misuse of tool and the importance of following safety procedures and instructions.
6. Do not make, or allow others to make, alterations or modifications to this tool. Replace all lost or illegible labels.
7. Follow all safety, installation and maintenance instructions provided with this tool. Establish proper safety procedures in accordance with local and national requirements to prevent accidental energizing of tool that can cause injuries.
8. If this tool is sold or change in ownership takes place, you must provide the new owner all safety instructions, notices and maintenance instructions you were originally provided. You can obtain additional copies of the instructions from Kentmaster, free of charge upon request.
9. Give copies of instructions to:
 - (A) Tool Operators**
 - (B) Maintenance Supervisor**
 - (C) Clean-up Supervisor**

GENERAL INFORMATION

COVERING: SAFETY PRECAUTIONS AND PLACING INTO SERVICE HYDRAULICLY POWERED BREAKING SAW

READ THIS MANUAL CAREFULLY BEFORE INSTALLING, OPERATING OR SERVICING THIS TOOL

IT IS THE RESPONSIBILITY OF THE EMPLOYER TO PLACE THIS INFORMATION INTO THE HANDS OF THE OPERATOR.

PLACING INTO SERVICE

 **WARNING** = Hazards or unsafe practices which could result in severe personal injury, death or substantial property damage.

 **CAUTION** = Hazards or unsafe practices which could result in minor personal injury, product or property damage.

 **NOTICE** = Important installation, operation or maintenance information.

 **WARNING** Installation, adjustment repair and maintenance of this tool must be made by trained and qualified personnel.

 **WARNING** Always disconnect power supply from tool before:

- (A) Installing or removing blade from tool.
- (B) Making repairs or adjustments to the tool.
- (C) performing maintenance or cleanup work.

DECLARATION OF CONFORMITY**DECLARATION OF CONFORMITY**DECLARATION DE CONFORMITE -DECLARACION DE CONFORMIDAD- ERKLARUNG BEZUGLICH EINHALTUNG DER VORSCHRIFTEN
DICHIARAZIONE DI CONFORMITA . CONFORMITEITSVERKLARING**MANUFACTURED BY:**FABRIQUE PAR:
FABRICADA POR:
HERGESTELLTVON:
FABBRICATO DA:
VERVAARDIGD DOOR:**KENTMASTER MFG CO., INC.**1801 SOUTH MOUNTAIN AVE.
MONROVIA, CALIFORNIA 91016
UNITED STATES OF AMERICA
TELEPHONE (626) 359-8888 FAX (626) 303-5151**TYPE / SERIES: HYDRAULIC BREAKING SAW**TYPE / SERIE:
TIPO / SERIE:
TYP / SERIE:
TIPO / SERIE:
TYPE / SERIE:**MODEL: HKM-I-H**MODELE:
MODELO:
MODELL:
MODELLO:
MODEL:**SERIAL NO. RANGE: XXXXX**

N SERIE: • GAMA DE No. DE SERIE: • SERIEN-NR.-BEREICH: • NUMERI DI SERIE: • SERIENUMMERS:

This product complies with the following European Community Directives:Ce produit est conforme aux directives de la Communauté européenne suivantes:
Este producto cumple con las siguientes Directrices de la Comunidad Europea:
Dieses Produkt erfüllt die folgenden Vorschriften der Europäischen Gemeinschaft:
Questo prodotto è conforme alle seguenti direttive CEE:
Dit produkt voldoet aan de volgende EG-richtlijnen:**98/37/EC, 2004/108/EC, 2006/95/EC****The following Standards were used to verify compliance with the Directives:**Les normes suivantes ont été utilisées pour vérifier la conformité avec les Directives:
Las siguientes Normas se usaron para verificar el cumplimiento de las Directrices:
Folgende Normen wurden angewandt, um Erfüllung der Vorschriften zu bestätigen:
Per verificare la conformità del prodotto alle direttive sono stati usati i seguenti standard:
De volgende normen zijn gebruikt om naleving van de richtlijnen te bevestigen:**EN 12984, EN 983, EN 982, EN 60204-1****Approved by:** _____RALPH KARUBIAN MONROVIA, CA. U.S.A
(Engineering Manager) (Directeur technique) (gerente de ingenieria) (verantwortlicher Konstruktionsleiter) (Responsabile tecnico) (ondersteunend technisch manager)**Date: AUG - 1 - 2009**

Kentmaster Worldwide Location

Kentmaster Equipment (Aust) PTY.LTD.

Unit 2,24 Central Court
Browns Plains Qld. 4118
Australia

Telephone: (07) 3806-8400

Fax: (07) 3806-7933

Australia@Kentmaster.com

Kentmaster do Brasil, Ltda.

Av. Dr. Joao Teodoro No. 805
Bairro De Vila Rezende
13405-240 Piracicaba, SP,
Brazil

Telephone #1: (019) 3 413 3113

Telephone #2: (019)983-4973

Fax: (019) 3 413 3113

Brazil@Kentmaster.com

Kentmaster (IRL) LTD.

Benamore, Dublin Road.
Roscrea,
CO, Tipperary,
Ireland

Telephone: (353) 0505-23292

Fax: (353) 0505-23299

Ireland@Kentmaster.com

Kentmaster Equipment (NZ) LTD.

5 Cooper Street
Havelock North
New Zealand

Telephone #1: (64) 6 8777 857

Telephone #2: 0800 KENTMASTER

Fax: (64) 6 8777 858

NewZealand@Kentmaster.com

Kentmaster South Africa (PTY) LTD.

Johannesburg - S. Africa
Unit 54 Sunnyrock Park
Sunrock Close, Germiston
South Africa

Telephone: (27) 11-455-3748

Fax: (27) 11-455-3749

SouthAfrica@Kentmaster.com

Kentmaster (UK) LTD.

Unit 16 Avonbank Ind. Centre
West Town Rd, Avonmouth-Bristol,
BS11 9DE
England

Telephone: (44) 117-923-5035

Fax: (44)-117-932-9010

UK@Kentmaster.com

Kentmaster Mfg. Co., Inc.

1801 South Mountain Ave.
Monrovia, CA, 91016
USA

Telephone #1: (626) 359-8888

Telephone #2: (800) 421-1477

Fax: (626) 303-5151

info@Kentmaster.com

Kentmaster Omaha

4417 South 139th Street
Omaha, NE, 68137
USA

Telephone #1: (402) 896-3355

Telephone #2: (800) 367-3181

Fax: (402) 896-3311

Omaha@Kentmaster.com

INDEX

OPERATING AND SAFETY INSTRUCTIONS	2
OPERATING INSTRUCTIONS	3
MAINTENANCE	3
SERVICE	3
PARTS BOOK	5
HKM-I-H	5
MOTOR DISASSEMBLY AND REASSEMBLY	6
HANDLES	7
NOSE ASSEMBLY	9
SAW MANDREL DISASSEMBLY	10
SAW MANDREL REASSEMBLY	10
TUBING DIAGRAM	11
TOOL ADJUSTMENTS:	12
GENERAL INFORMATION	15
DECLARATION OF CONFORMITY	16
<i>Kentmaster Worldwide Location</i>	<i>17</i>
INDEX	18
FIGURES - INDEX	18

FIGURES - INDEX

Figure 1 MODEL HKM-I-H – BLADE REPLACEMENT	4
Figure 2 MODEL “HKM-I-H” – MAIN ASSEMBLY	5
Figure 3 BOM FOR MODEL “HKM-I-H”	6
Figure 4 6600530: AIR HANDLE	7
Figure 5 6620710: AIR HANDLE, ASSEMBLY	8
Figure 6 6622190: NOSE ASSEMBLY	9
Figure 7 BOM FOR 6622190: NOSE ASSEMBLY	10
Figure 8 HKM-I-H WITH HPP-I-F DIAGRAM WITH ANTI-TIE DOWN	11