



**FAST**  
**ROTATOR**®  
PATENTED

INNOVATIVE GEOMETRY • AUTONOMOUS WORK CELLS  
40% PRODUCTIVITY INCREASE • EASY (UN)LOADING  
WORK SECURITY • FLEXIBILITY • FUNCTIONALITY

# Introduction



FastRotator is an innovative machine that assists the welding construction. Through a revolutionary process this equipment is characterized by its simplicity and process efficiency.

It allows a smooth pieces movement rotation, quicker and controlled, reducing the use of overhead cranes only for operations of easy loading and unloading.

Our equipment can be manufactured according to the weight and the size of the pieces you need to turn.

In a proven form you get a 40% increase of productivity on fitting and welding processes.

With an accessible design, in just a few seconds, FastRotator allows the welder to turn easily and securely the pieces, adjusting the working height into an ergonomic position.

By purchasing a FastRotator device, you prove your trust in our machines and we will do our best to deserve it.

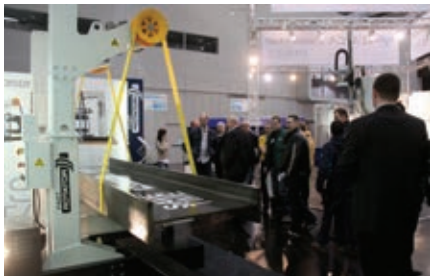

Le FastRotator est une machine innovatrice, auxiliaire à la construction soudée. Grâce à un procédé révolutionnaire, cette machine se caractérise par sa simplicité et efficacité.

Il permet la rotation de pièces en mouvements doux, rapides et contrôlés, donc, l'utilisation de ponts roulants et réduite uniquement au chargement et déchargement des pièces.

L'équipement peut être construit d'accord avec le poids et dimensions des pièces de vous nécessités.

Il permet de forme testée l'augmentation de 40% de la productivité d'assemblages et processus de soudage.

Avec un design pratique d'accessibilité, en quelques secondes, le FastRotator permet que le soudeur manœuvre simplement et facilement les pièces en toute sécurité et également les adapte aux positions de travail.

En achetant un équipement FastRotator, vous montrez votre confiance dans nos machines et en ce qui nous concerne, nous feront notre meilleur pour recevoir cette confiance.



Der FastRotator ist eine innovative Anlage zur Vereinfachung der Herstellung von Schweißkonstruktionen. Diese neuartige Maschine zeichnet sich durch ihre einfache Konstruktion und Prozesseffizienz aus.

Sie erlaubt eine gleichmäßige, schnelle und kontrollierte Rotation der Teile und reduziert die Notwendigkeit von Brückenkränen auf das einfache Be- und Entladen der Bauteile.

Unsere Anlagen können für Ihre Bauteilabmessungen und Stückgewichte universell angepasst werden.

In einer bewährten Form erreichen Sie Produktivitätssteigerungen bei Montage- und Schweißprozessen von bis zu 40%.

Mit seiner barrierefreien Gestaltung erlaubt der FastRotator dem Arbeiter ein einfaches und sicheres Wenden der Bauteile und das Einstellen der Arbeitshöhe auf eine ergonomische Position innerhalb weniger Sekunden.



Mit dem Kauf des FastRotator beweisen Sie Ihr Vertrauen in unsere Anlagen, dem wir gerecht werden wollen.



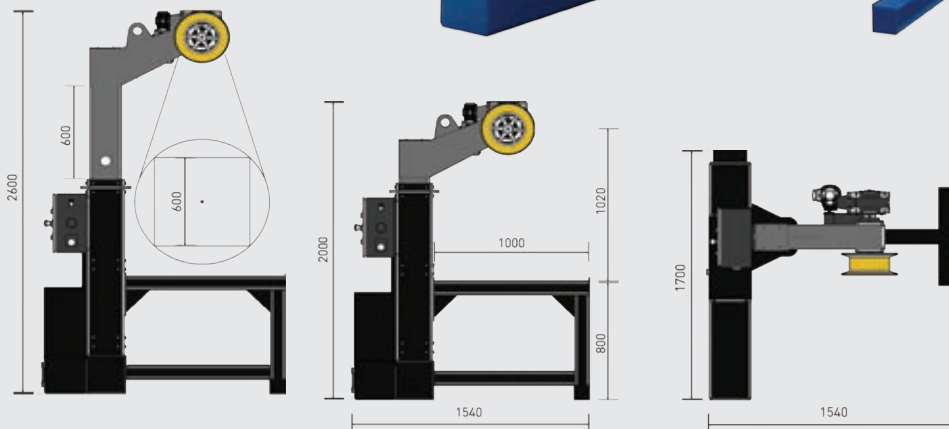

Improve your  
Productivity



		mm	
	850		600
			750x300
<b>Specifications</b>			
<i>Technische Daten - Caractéristiques</i>			
Capacity* <i>Kapazität-Capacité</i>	4 ton./Pair <i>paar - paire</i>		
Rotation speed <i>Drehgeschwindigkeit Vitesse de rotation</i>	18 sec/180°		
Voltage <i>Spannung-Tension</i>	400V		
Power consumption <i>Leistungsaufnahme Puissance de consommation</i>	4kW		
Hydraulic oil/Quantity <i>Hydrauliköl / Menge Huile hydraulique/Quantité</i>	ISO VG46 25 liters <i>liter - litres</i>		
Remote control <i>Fernsteuerung Commande à distance</i>	optional <i>fakultativ optionnel</i>		

\*different capacity upon request

**Specifications***Technische Daten - Caractéristiques*

Capacity* <i>Kapazität-Capacité</i>	6 ton./Pair <i>paar - paire</i>
Rotation speed <i>Drehgeschwindigkeit Vitesse de rotation</i>	18 sec/180°
Voltage <i>Spannung-Tension</i>	400V
Power consumption <i>Leistungsaufnahme Puissance de consommation</i>	7kW
Hydraulic oil/Quantity <i>Hydrauliköl / Menge Huile hydraulique/Quantité</i>	ISO VG46 25 liters <i>liter - litres</i>
Remote control <i>Fernsteuerung Commande à distance</i>	optional <i>fakultativ optionnel</i>

\*different capacity upon request

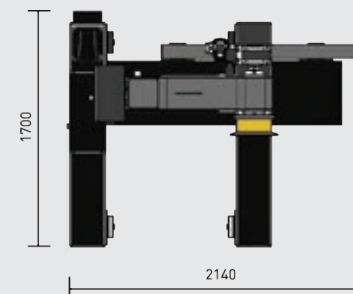
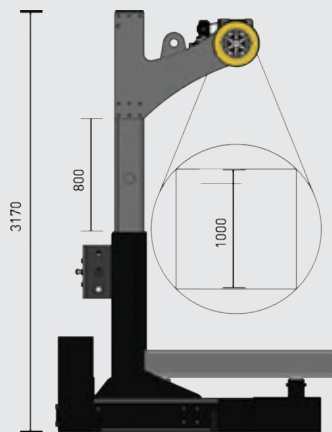
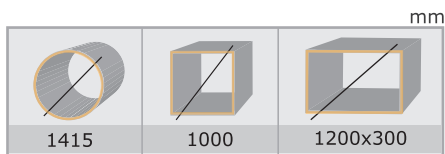

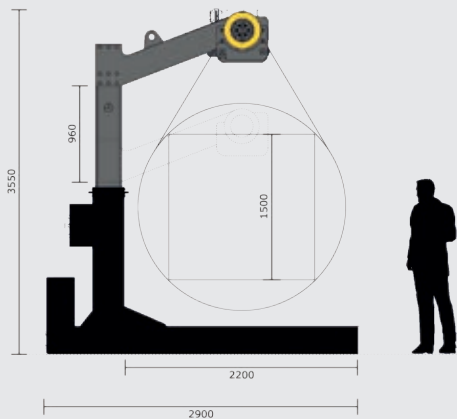

Specifications	
Technische Daten - Caractéristiques	
Capacity* <i>Kapazität- Capacité</i>	8 ton./Pair <i>paar - paire</i>
Rotation speed <i>Drehgeschwindigkeit</i> <i>Vitesse de rotation</i>	18 sec/180°
Voltage <i>Spannung- Tension</i>	400V
Power consumption <i>Leistungsaufnahme</i> <i>Puissance de consommation</i>	7kW
Hydraulic oil/Quantity <i>Hydrauliköl / Menge</i> <i>Huile hydraulique/Quantité</i>	ISO VG46 30liters <i>liter - litres</i>
Remote control <i>Fernsteuerung</i> <i>Commande à distance</i>	optional <i>fakultativ</i> <i>optionnel</i>

\*different capacity upon request



Work  
Safely

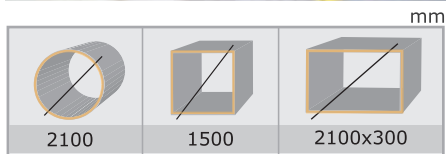

## Specifications

Technische Daten - Caractéristiques

Capacity* <i>Kapazität - Capacité</i>	25 ton./Pair <i>paar - paire</i>
Rotation speed <i>Drehgeschwindigkeit</i> <i>Vitesse de rotation</i>	35 sec/90°
Voltage <i>Spannung - Tension</i>	380/420V
Power consumption <i>Leistungsaufnahme</i> <i>Puissance de consommation</i>	22kW <i>(max. simultaneous)</i> 32kW <i>(installed)</i>
Hydraulic oil/Quantity <i>Hydrauliköl / Menge</i> <i>Huile hydraulique/Quantité</i>	ISO VG46 200 liters <i>liter - litres</i>
Remote control <i>Fernsteuerung</i> <i>Commande à distance</i>	optional <i>fakultativ</i> <i>optionnel</i>

\*different capacity upon request

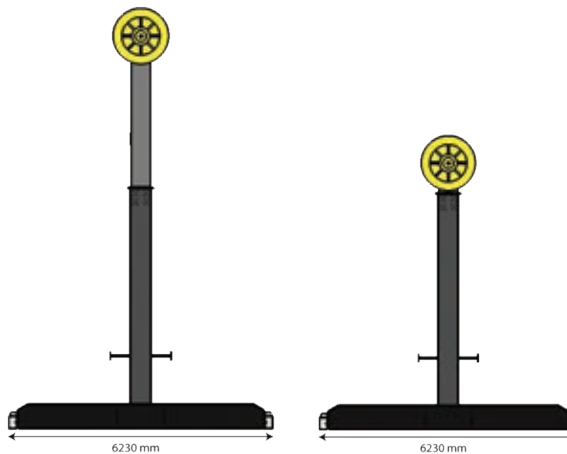
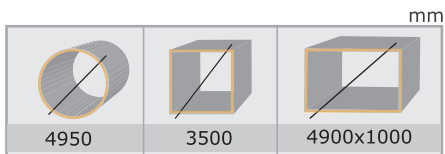
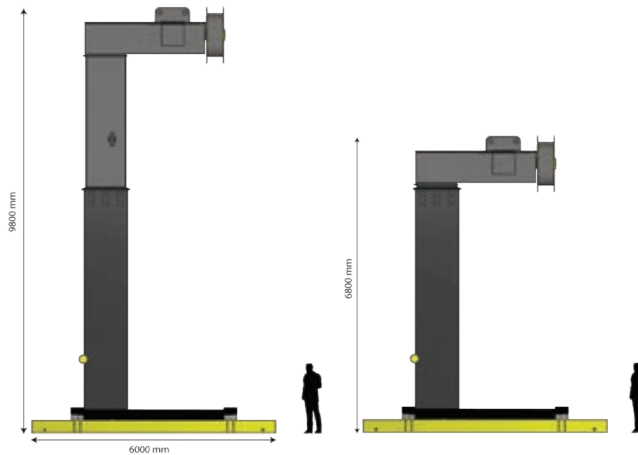

We proudly present...

...the biggest FastRotator in the World!



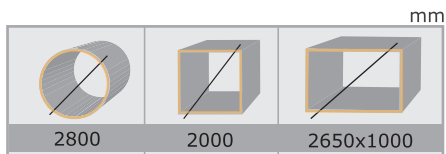

Specifications	
Technische Daten - Caractéristiques	
Capacity <i>Kapazität - Capacité</i>	12 ton./Pair <i>paar - paire</i>
Rotation speed <i>Drehgeschwindigkeit Vitesse de rotation</i>	30 sec/90°
Voltage <i>Spannung - Tension</i>	400V
Power consumption <i>Leistungsaufnahme Puissance de consommation</i>	15kW
Hydraulic oil/Quantity <i>Hydrauliköl / Menge Huile hydraulique/Quantité</i>	ISO VG46 60 liters <i>liter - litres</i>
Remote control <i>Fernsteuerung Commande à distance</i>	optional <i>facultativ optionnel</i>

\*different capacity upon request



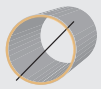

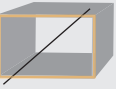
mm		
		
3500	2500	3200x1500
<b>Specifications</b>		
<i>Technische Daten - Caractéristiques</i>		
Capacity* <i>Kapazität- Capacité</i>	20 ton./Pair <i>paar - paire</i>	
Rotation speed <i>Drehgeschwindigkeit</i> <i>Vitesse de rotation</i>	30 sec/90°	
Voltage <i>Spannung- Tension</i>	400V	
Power consumption <i>Leistungsaufnahme</i> <i>Puissance de consommation</i>	15kW	
Hydraulic oil/Quantity <i>Hydrauliköl / Menge</i> <i>Huile hydraulique/Quantité</i>	ISO VG46 60 liters <i>liter - litres</i>	
Remote control <i>Fernsteuerung</i> <i>Commande à distance</i>	optional <i>fakultativ</i> <i>optionnel</i>	



\*different capacity upon request

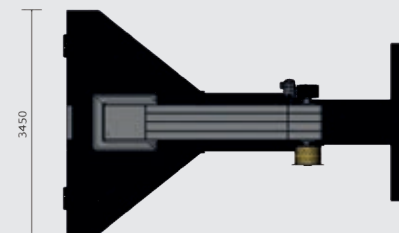
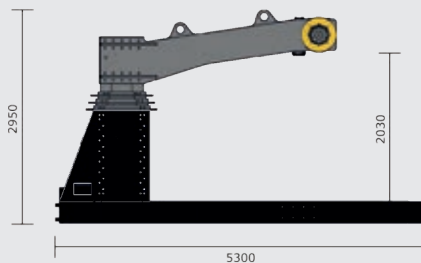
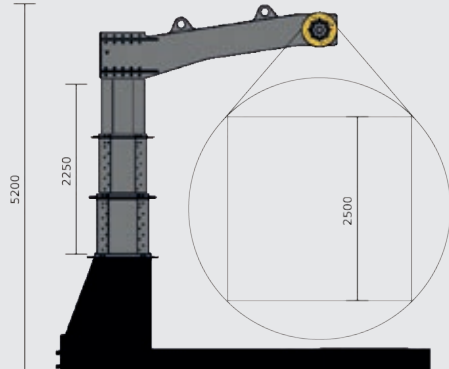



■ FR 604 - p.2



■ FR 1006 - p.3



■ FR 1508 - p.4



■ FR 2012 - p.6



■ FR 2520 - p.7



■ FR 3525 - p.5



**1800 818 448**  
info@ronmack.com.au

### Head Office & Metalwork Showroom

8 Hector Street West,  
Osborne Park  
Western Australia 6017

Phone (08) 9445 0700  
Fax (08) 9446 3635  
Freecall: 1800 818 448

### Woodwork Showroom (Perth)

50 Hector Street West,  
Osborne Park  
Western Australia 6017

Phone (08) 9445 0700  
Fax (08) 9446 3635  
Freecall: 1800 818 448

### Melbourne - Office & Showrooms

55 Lara Way  
Campbellfield  
Victoria 3061

Phone (03) 8359 8400  
Fax (03) 9357 7684

### Adelaide Office

PO Box 44,  
Greenwith  
South Australia 5125

Phone 0439 094 486  
Fax (08) 8568 2739

### New South Wales Office

PO Box 310,  
Lennox Head  
New South Wales 2478

Phone 0422 237 409  
Fax (02) 6687 7267

### Queensland Office

PO Box 5119,  
Alexandra Hills  
Queensland 4161

Phone 0439 901 646  
Fax (07) 3824 6389

For enquiries from Tasmania, Northern Territory, ACT, New Zealand or Asia-Pacific regions please contact us in our Perth office.

**[www.ronmack.com.au](http://www.ronmack.com.au)**