

EZN1540-SG

5-Megapixel IR & WDR,
Outdoor Bullet Network Camera



ONVIF



HEVC Advance™
Covered by Patents at patentlist.hevcadvance.com

Features

- 5MP Progressive scan CMOS sensor
- Equipped with 3.6mm fixed lens
- Triple-streaming from H.265 / H.264
- Supports 3D DNR (Digital Noise Reduction)
- Provides True Day/Night functionality with automatic IR filter operation
- Extended IR range up to 30m / 98ft.
- Supports ONVIF
- Weather-proof IP66 rated
- Supports PoE and 12VDC

Dimensions

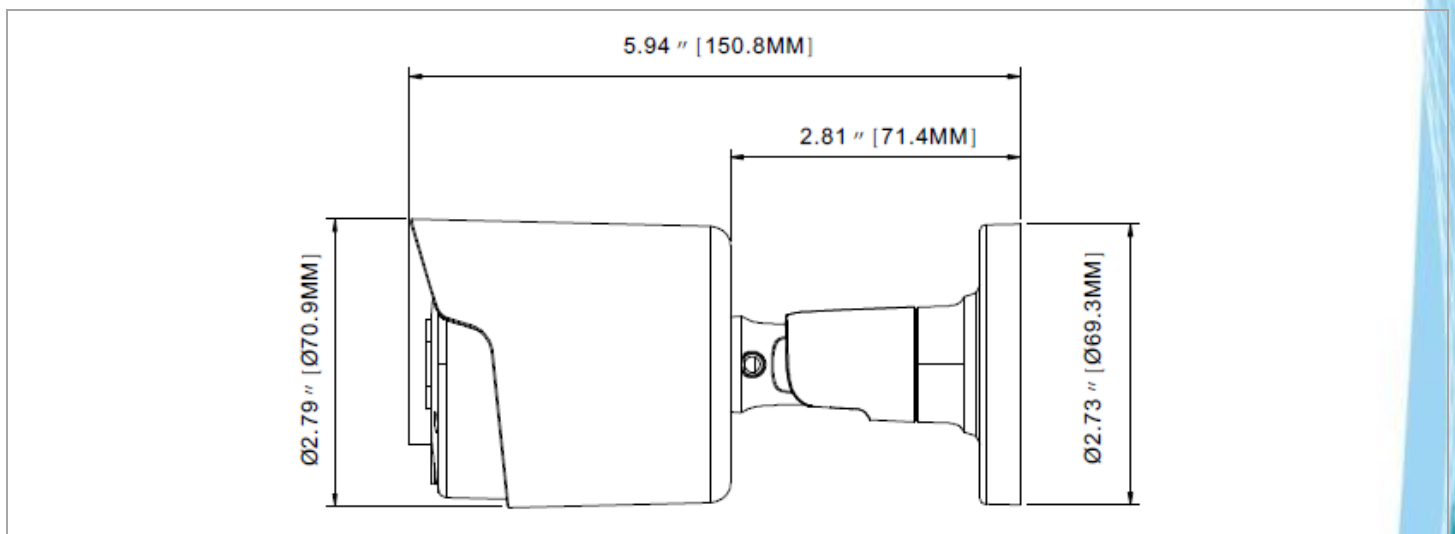

Specification

Camera	
Pickup Device	1/2.7", 5.0 megapixel, progressive scan, CMOS
Lens	3.6mm, fixed lens, F No.1.6±10%
Angle of View	Horizontal:81°, Vertical:57°, Diagonal:108°
Shutter	1/5 ~ 1/20000s
Minimum Illumination	Colour: 0.05Lux (F1.6, AGC ON) 0Lux with IR
Day/Night	IR cut filter with auto switch (Day/Night/Auto/Schedule)
IR Range	Up to 30m (98ft) IR range
Video	
Video Compression	H.265/H.264
Frame Rate	Main Stream 5MP(2592*1944), 4MP(2592x1520),3MP(2304x1296), 1080P(1920x1080), 720P(1280x720), Sub Stream 720P(1280x720), VGA(640x480),QVGA(320x240) Mobile Stream VGA(640x480), QVGA (320x240)
Max. Framerate	Max. 20fps@5MP, Real Time @4MP/1080P/720P/VGA/QVGA
Bitrate control method	CBR/VBR
Privacy Masking	Off/On (4 Zone, Rectangle)
Motion Detection	Off/On (8 Level)
Image	
Backlight Compensation	Off/On (5 Zone)
Wide Dynamic Range	DWDR
Digital Noise Reduction	3D DNR
Gain Control	Auto
White Balance	Auto/Manual
Flip / Mirror	Flip/Rotation
Network	
Protocols	TCP/IP,HTTP,DHCP,DNS,DDNS,RTP/RTSP, SMTP,NTP,UPnP,SNMP,HTTPS,FTP
Compatible Integration	ONVIF
Web Viewer	IE8,9,10,11, Chrome 44/lower, Firefox 51/lower
General	
Power	DC12V/POE(IEEE802.3af)
	Power consumption: TBD
Storage	Micro SD slot, up to 256GB
Alarm	NA
Audio	Built-in microphone
Dimensions (Ø x H)	Ø70.9x150.8mm
Net Weight	appr 375g
Material	White/Metal
Working Environment	-30 ~ +60°C/less than ≤ 95% RH
Ingress Protection	IP66
Reset Button	Supported

Find Out More At:

EverFocus Taiwan HQ:

TEL: +886 2 26622338

www.everfocus.com.tw

marketing@everfocus.com.tw

EverFocus USA - California:

TEL: +1 626 844 8888

www.everfocus.com

sales@everfocus.com

International Branch Offices:

China, Japan