

ADANDE SLIMLINE SIDE ENGINE UNIT (VLS)



Applications

- Meat and fish prep & storage
- Deli and larder prep & storage
- Pastry and pasta prep & storage
- Dessert prep & storage
- Point of use storage
- Frozen storage by the deep fryer
- Mise en Place prep & garnish storage



Operational Benefits

- Reliable: amazing temperature stability
- Green: extremely energy efficient
- Cuts food wastage
 - Food does not dehydrate
 - No condensation on the food
- Ergonomically efficient
- Minimal maintenance costs
- Quick and easy to clean
- Robust and reliable

Fridge to Freezer.
Each drawer is switchable in minutes. Accurate and stable at any temperature.
(-22°C to +15°C)

+15°C ← → -22°C

VLS2 R600a

Energy rating per drawer module

DIMENSIONS - VLS2.CW - Elevation & Plan View

Storage Capacity
Per Drawer
4 x 1/1 GN Pans
65mm Deep or equivalent

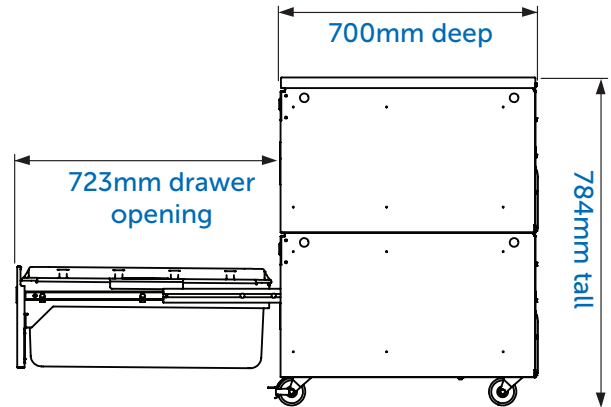
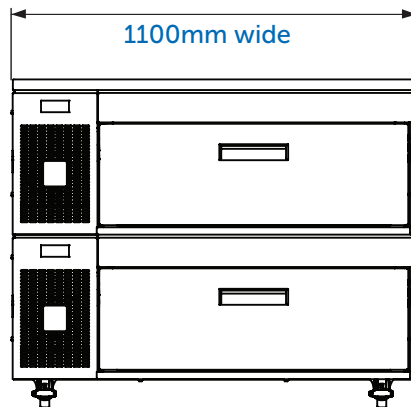

TOP & BASE OPTIONS - Worktops and Castors

(HS) - protects unit tops exposed to temperatures up to 200°C

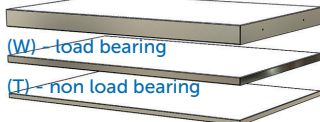

When combining a standard height drawer with a slimline drawer

	Standard Castors		Plinth Slides		Standard Castors		Plinth Slides	
Finished Height & Load Bearing Weight with Worktop (W)	784mm	VLS2.CW	n/a		n/a		n/a	
	230 kg		n/a		n/a			
Finished Height & Load Bearing Weight with Cover Top (T)	n/a		699mm	VLS2.PT	833mm	VNS2.CT	757mm	VNS2.PT
	n/a		0 kg		0 kg		0 kg	

CLIMATE TESTING: Tested to Climate Class 4 (30°C and 55% relative humidity) for temperature and energy consumption. Tested to Climate Class 5 (40°C and 40% relative humidity) for temperature
MAINS: 230 Vac 50 Hz also 60 Hz available.
(BC): Blast Chiller Option available.

Imported and distributed exclusively by:

Tom Stoddart Pty Ltd
39 Forest Way, Karawatha, QLD 4117

1300 79 1954

www.stoddart.com.au
adande@stoddart.com.au

