



LIFTMASTER

Universal Bin Lifter

Operating Manual

Universal Bin Lifter Operating Manual—OM0005E/3

This manual contains important safety, installation and operating instructions for this unit. Read this manual thoroughly and completely, and retain for future reference. This unit can cause serious injury to personnel or damage to property if used incorrectly, therefore do not use this machine for any other purpose apart from its intended use. Using this unit incorrectly may void warranty.

Any damage audible or visible to this unit should be addressed at the time of discovery. Electrodrive Pty Ltd can provide parts and service support on request through its service partner company:

Serviced Equipment Pty Ltd

p: 1300 934 471

e: service@fallshaw.com.au

Made in Australia by:

Electrodrive Pty Ltd

2A Ayton Street, Sunshine North VIC Australia 3020

p: 1300 934 471 (within Australia)

p: +61 (03) 9300 8521 (International)

e: sales@electrodrive.com.au

w: www.electrodrive.com.au

© Electrodrive

Contents

Introduction	4
Control panel	5
Operating instructions	6
Safety check	6
Moving the bin lifter to the operating position	6
Emptying a wheelie bin	6
Maintenance	7
Batteries.....	7
Control circuit fuse.....	7
Power circuit fuse	7
Warranty	8
Modifications and misuse will void your warranty	8
Misuse	8
General wear items not covered under warranty.....	8
Spare parts list	9
Wiring diagram	10
Service log	12

Introduction

The Liftmaster Universal Bin Lifter is a fully enclosed electro-hydraulic powered bin lifter rated to lift 80, 120, 140 and 240 litre wheelie bins weighing up to 250 kg.



Model	Working Load Limit	Max Load
UBL250	96 kg	250 kg

Control panel

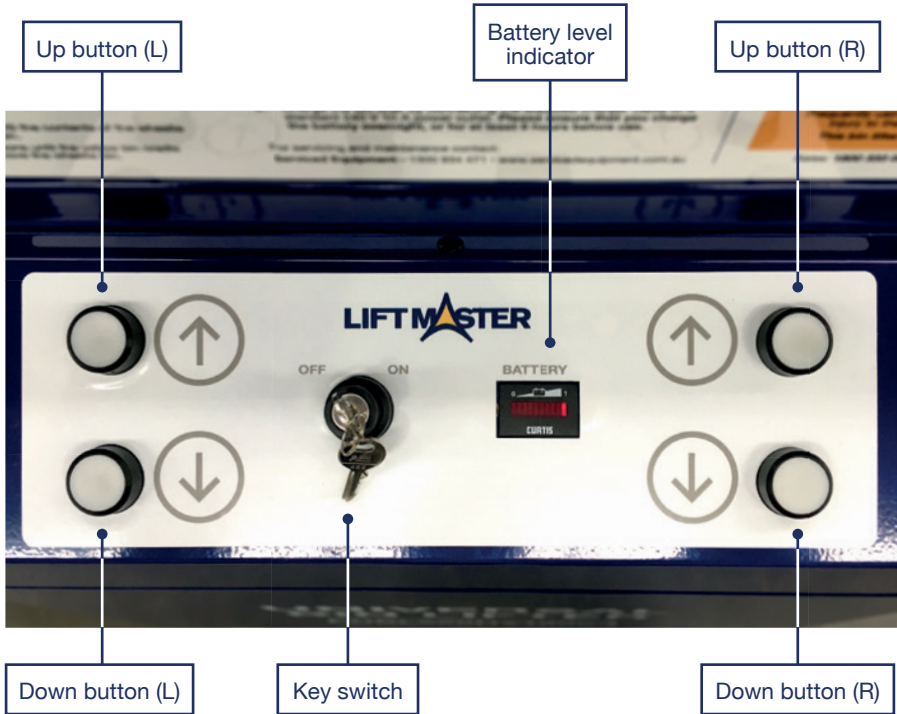

Operating instructions

Safety check

Before using this bin lifter, the operator should complete the following check:

- Ensure the unit has not been damaged in transit.
- Look for damage to the pallet and cuts or tears in the plastic wrapping.

Moving the bin lifter to the operating position

1. Using both frame handles, push the bin lifter towards the skip bin.
2. Position the bin lifter against the skip bin and press down on the two red castor pedals to activate the total brakes.



Emptying a wheelie bin

1. Unlock and open the safety door.
2. Push a wheelie bin forward into the cradle and close the door.
3. Move to the control panel and turn the key switch to the ON position.
4. Press and hold both UP buttons to lift the cradle and tilt the wheelie bin.
5. When the wheelie bin is empty, press both DOWN buttons to return the cradle to ground level.
6. Open the safety door and remove the wheelie bin.
7. When all wheelie bins have been emptied, close and lock the safety door, and turn the key switch OFF.



If the wheelie bin cradle does not move up or down smoothly, the wheelie bin may be overloaded or the battery may need charging.

It is recommended that keys to the control panel and safety door are removed when the unit is not in use.

Maintenance

Batteries

The batteries are sealed and maintenance free. The bin lifter is installed with an automatic charger. The automatic features on the charger together with sealed gel batteries ensures that there is a minimum amount of gas, if any at all, expelled from the batteries during charging. Do NOT try to open these batteries.

To ensure maximum battery life, ensure that you do the following:

1. Always charge batteries once the job is done or day's use is complete.
2. Always charge the batteries to 100% capacity. Leave batteries on charge until the battery level display indicator indicate that it is full.
3. Ensure there is enough airflow around the Bin Lifter to help keep the batteries as cool as possible.
4. If batteries are not used for lengthy periods of time, it is recommended to give them a maintenance charge once every 2 months if disconnected from machine.



Opportunity charging is NOT recommended. This can shorten battery life.

Control circuit fuse

The control circuit is protected against inadvertent current over-loads. These are located underneath the control panel.

This 5A fuse can be accessed via service panel under the control panel of the bin lifter.

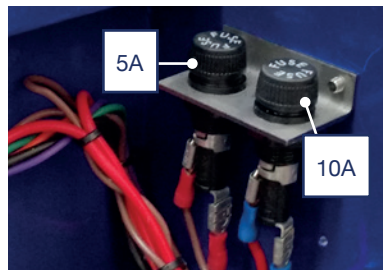

Power circuit breaker

The bin lifter is fitted with a 60A circuit breaker in the battery supply circuit. Failure of this fuse indicates the bin lifter has sustained overload or an internal malfunction that requires immediate service. If the power circuit fuse has tripped, contact Electrodrive.

Warranty

Electrodrive Pty Ltd warrants that this product is free from defects in materials and workmanship for a period of twelve months from the date of dispatch from the Electrodrive plant.

If a defect is reported, Electrodrive will repair or replace the defective part, at its own discretion. This warranty does not apply if this unit has been misused, damaged, or modified in any way.

Modifications and misuse will void your warranty

The following activities (including, but not limited to) are examples:

Modifications

- The machine is re-wired by an unauthorised service agent
- There are modifications to the body or frame of the machine
- Use of non-specified parts
- The machine is serviced by an unauthorised service agent

Misuse

- Overloading the unit during lifting
- Carrying people or other foreign objects
- Exposed to rain or other precipitation
- Exposed to a corrosive environment
- Not being charged adequately

General wear items not covered under warranty

- Buttons and key switch
- Door lock and interlock mechanism
- Cables, bearings, rollers and cam bar
- Pulley
- Hydraulic power unit and hydraulic cylinder
- Tyres and castors

Spare parts list

Part	Description
LMUBELCSMART	12 & 24V smart charger
LMUBLBATTERYGEL	63AH gel battery
LMUBBATIND	Curtis battery display indicator
PLGHBL250CONTNO	Contact block normally open
PLGHBL250CONTNC	Contact block normally closed
PLGHBL250HOLDER	Contact block holder
LMAONOFFSW	On/off key switch
BUTHBL250PL	Push button, plain white
LMSIMPLIMITSW	Limit switch 0
FUS5AMP3AG	Fuse 5amp 3 AG
EL1919	Circuit break – 60amp self-resetting
HYDCYLAG1520A	Hydraulic cylinder 1.5" x 20"
HYDPWP-12V1600W-SA	Hydraulic power pack, 12V, 1600W, SA
HYDHOSEUBLSIMPPU	Hydraulic hose pressure Simplus/UBL power unit
HYDHOSEUBLSIMTPU	Hydraulic hose tank Simplus/UBL power unit
HYDHOSEUBLSIMT	Hydraulic hose pressure Simplus/UBL
HYDHOSEUBLSIMP	Hydraulic hose tank Simplus/UBL
HUS150/OZPSA	Rear castor
SI2885	Front castor
SUBUBLSIM-B-03-004	Pulley – IP9703 tension idler
MCHUBLSIM-A-00-003	Bin lifter universal cam roller
CBLUBL250RHS	Pulley cable RHS UBL250
CBLUBL250LHS	Pulley cable LHS UBL250

Wiring diagram

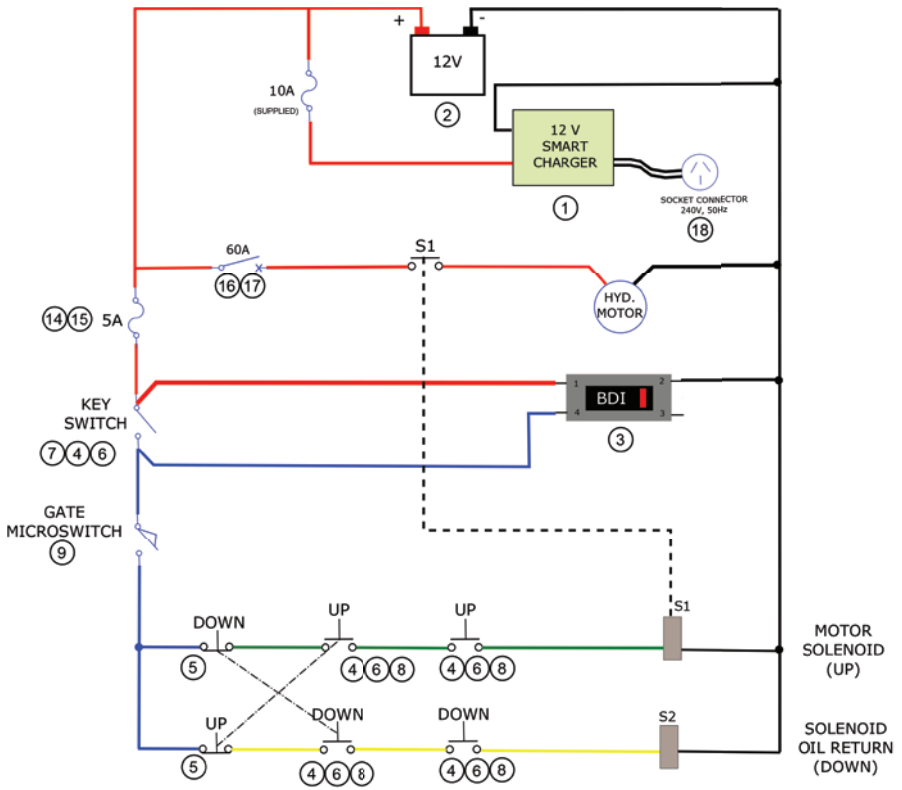

Item no.	Part	Description	Quantity
1	LMUBELCSMART	12 & 24V smart charger	1
2	LMUBLBATTERYGEL	63AH gel battery	1
3	LMUBBATIND	Curtis battery display indicator	1
4	PLGHBL250CONTNO	Contact block normally open	5
5	PLGHBL250CONTNC	Contact block normally closed	2
6	PLGHBL250HOLDER	Contact block holder	5
7	LMAONOFFSW	On/off key switch	1
8	BUTHBL250PL	Push button, plain white	4
9*	LMSIMPLIMITSW	Limit switch 0	1
10	EL2560	Gland grey (25 mm)	1
11	EL1820	Cable tie	6
12	EL1870	E-cable tie mount (25 mm)	10
13	CBLCORHOSE16MM	Corrugated (16 mm) hose	1 metre
14	EL2500	Panel mount fuse holder (5A)	1
15	FUS5AMP3AG	Fuse 5amp 3 AG	1
16	EL2495	Fuse, base mount holder 425A RS p/n: 380-9923	1
17	FUS125ABLDWN	125amp boldtdown fuse RS comp p/n: 226-0850	1
18	EL3200	Socket – 3 pin – line (charger/female)	2
19	EL1125	Grommet (13 mm)	2

* Exclude item 9 for Simplus version

Service log

Service recommendations

To ensure this equipment is kept in a safe and reliable condition, it is important to follow a preventative maintenance program. Maintain a log of the service work on the cards below, and always use an approved Electrodrive service agent to conduct the works. Approved service personnel will be provided with all necessary documents and components in service repair, including but not limited to, circuit diagrams, component part lists, descriptions, service checklists and spare parts.

6 month service

Date of service		Service agent	
Machine serial number			
Summary of works			
Next service due			

12 month service

Date of service		Service agent	
Machine serial number			
Summary of works			
Next service due			

18 month service

Date of service		Service agent	
Machine serial number			
Summary of works			
Next service due			

24 month service

Date of service		Service agent	
Machine serial number			
Summary of works			
Next service due			

30 month service

Date of service		Service agent	
Machine serial number			
Summary of works			
Next service due			

36 month service

Date of service		Service agent	
Machine serial number			
Summary of works			
Next service due			

42 month service

Date of service		Service agent	
Machine serial number			
Summary of works			
Next service due			

48 month service

Date of service		Service agent	
Machine serial number			
Summary of works			
Next service due			

54 month service

Date of service		Service agent	
Machine serial number			
Summary of works			
Next service due			

60 month service

Date of service		Service agent	
Machine serial number			
Summary of works			
Next service due			

Mobility solutions to help you push, pull & lift with ease.

www.electrodrive.com.au