



Electric ride-on/pedestrian pallet truck

ERE 120-230

Lift height: 122 mm / Load capacity: 2000-3000 kg

ERE 120-230

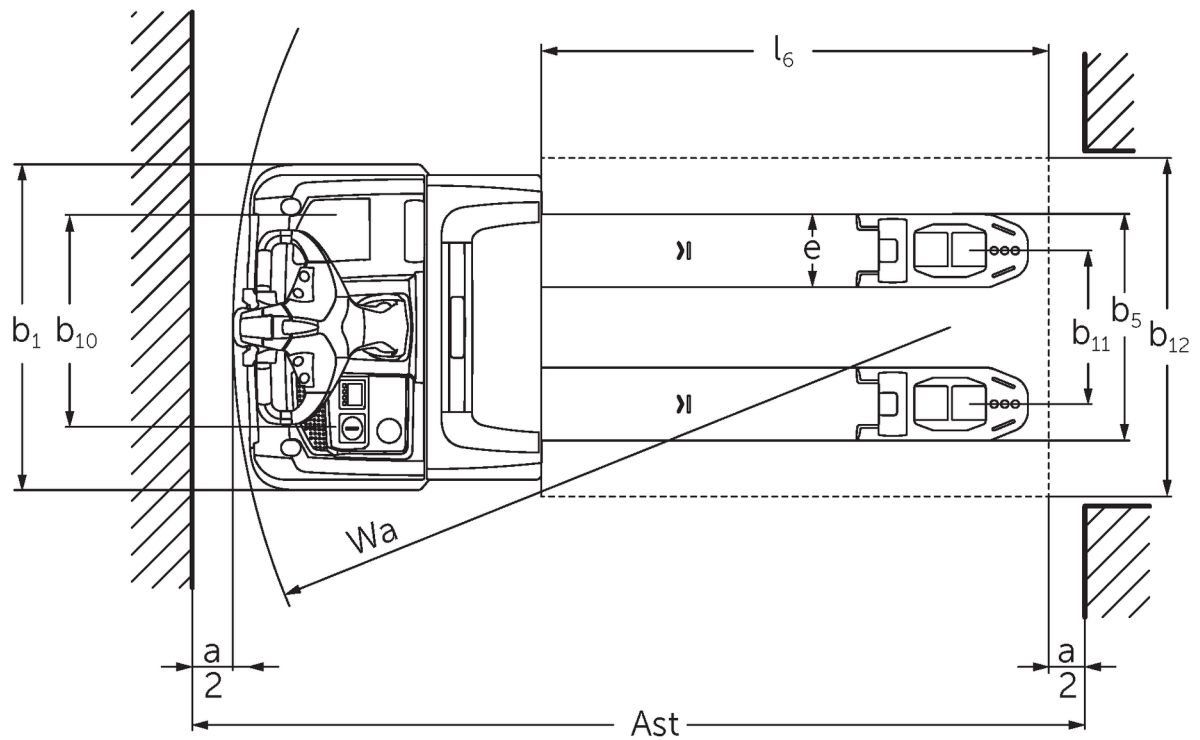

ERE 120-230

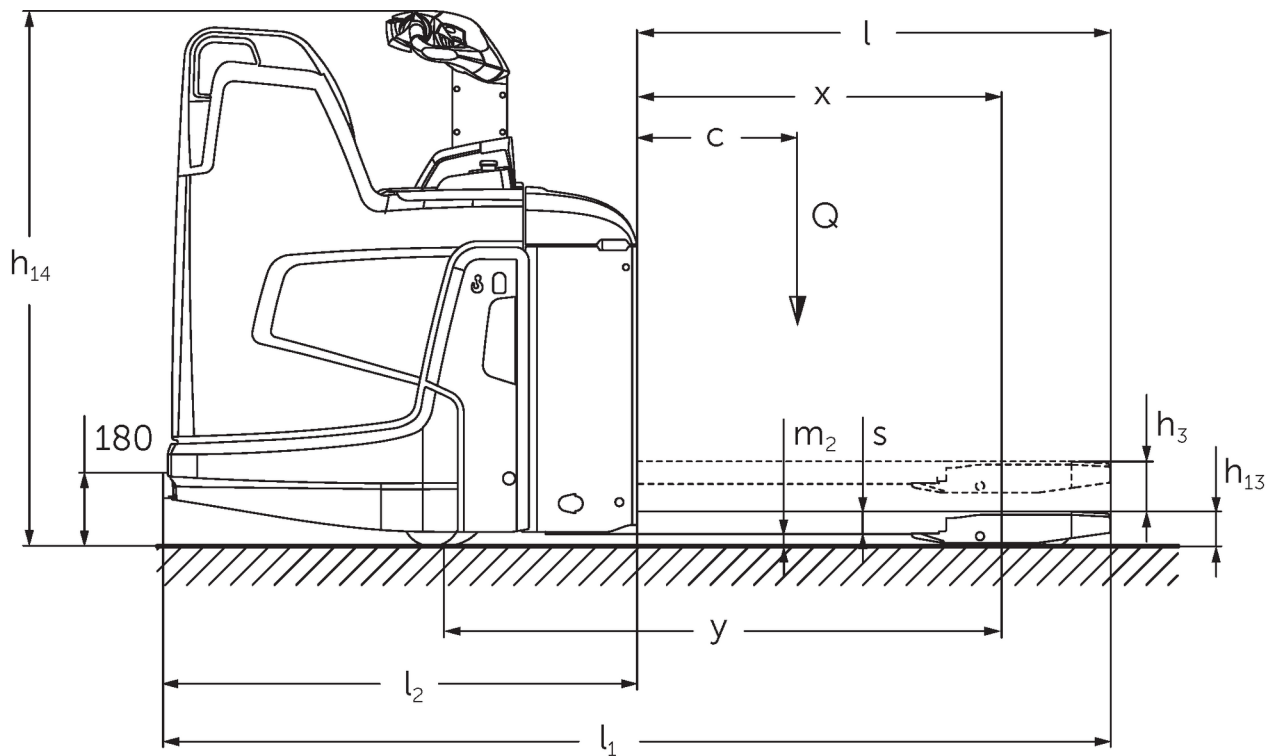

VDI table

Stand-on: 07/2023

Characteristic	1.1	Manufacturer (abbreviated description)	Jungheinrich								
			ERE 120 6km/h	ERE 120 9 km/h	ERE 125	ERE 225	ERE 225 drivePLUS	ERE 230	ERE 230 drivePLUS		
Characteristic	1.2	Manufacturer's type designation									
	1.3	Drive	Electric								
	1.4	Operation	Tiller								
	1.5	Load capacity/load	Q kg	2000		2500		3000			
	1.6	Load centre distance	c mm	600							
	1.8	Load distance, centre of drive axle to fork	x mm	908							
	1.9	Wheelbase	y mm	1378					1450		
	Weights	2.1	Service weight	kg	400		404		424		
		2.1.1	Service weight (incl. battery)	kg	-					725	
2.2		Axle load laden front/rear	kg	1825 / 795		2090 / 1126		2494 / 1239			
2.3		Axle load unladen front/rear	kg	138 / 474		159 / 550		160 / 565			
Wheels/suspension system	3.1	Tyres	Vulkollan ®/PU + quartz/Vulkollan ®								
	3.2	Tyre size, front	Ø 230 x 65			Ø 230 x 77					
	3.3	Tyre size, rear	Ø 85 x 110 / Ø 85 x 85					Ø 85 x 85			
	3.4	Additional wheels	Ø 140 x 57								
	3.5	Wheels, number front/back (x=driven)	1x +2/2 oder 4					1x +2/4			
	3.6	Tread width, front	b ₁₀ mm	363							
	3.7	Tread width, rear	b ₁₁ mm	512							
Basic dimensions	4.4	Lift (h3)	h ₃ mm	122							
	4.9	Height of tiller handle in drive position min./max.	mm	1137 / 1419							
	4.15	Height, lowered	h ₁₅ mm	85							
	4.19	Overall length	l ₁ mm	1847				1919			
	4.20	Length including fork shank	l ₂ mm	697				769			
	4.21.1	Overall width	b ₁ mm	770							
	4.22	Fork dimensions	s/ e/l mm	55 x 172 x 1150							
	4.25	Width across forks	b ₅ mm	535							
	4.32	Ground clearance centre of wheelbase	m ₂ mm	30							
	4.34.1	Aisle width (pallet 1000x1200 sideways)	Ast mm	2411				2483			
	4.34.2	Aisle width (pallet 800x1200 length)	Ast mm	2299				2372			
	4.34.8	Aisle width (pallet 800x1200 crosswise)	Ast mm	2414				2486			
	4.35	Turning radius	W _a mm	1604				1677			
E-motor/ElectroPerformance data	5.1	Travel speed laden/unladen	km/h	6 / 6	8 / 9	9 / 9	9.5 / 12.5	9.5 / 14	6 / 12.5	6 / 14	
	5.2	Lift speed laden/unladen	m/s	0.04 / 0.04		0.05 / 0.07					
	5.3	Lowering speed laden/unladen	m/s	0.05 / 0.04		0.05 / 0.05					
	5.8	Max. gradeability laden/unladen	%	5 / 7	8 / 16				6 / 16		
	5.10	Service brake	generative								
6.1	Drive motor, performance S2 60 min	kW	2		2.8		3.2		2.8		3.2

E-motor/ElectroPerformance data

	6.2	Lift motor, performance with S3	kW	1.2		2.2				
	6.3	Battery according to DIN 43531/35/36		B	-				B	
	6.4	Battery voltage/nominal capacity	V / Ah	24 / 250				24 / 375		
	6.5	Battery weight	kg	230				297		
	6.6.1	Energy consumption according to EN cycle	kWh/h	0.4	0.43	0.4	0.35	0.39	0.36	0.41
	6.6.2	CO2 equivalent as per EN 16796	kg/h	0.2						
	6.7	Throughput	t/h	114	142	156	184	222	220	266
	6.8.1	Energy consumption with max. throughput	kWh/h	0.74	1.11	1.18	1.29	1.89	1.45	2.05
Other	8.1	Type of drive control		AC						
	10.7	Sound level as per EN12053, operator's ear	dB (A)	63		64	67	64	67	

- This data sheet according to VDI guideline 2198 only states the technical values of the standard truck. Different tyres, other masts, additional equipment etc. may result in different values.

The German production facilities in
Norderstedt, Moosburg and Landsberg
are certified as well as our Genuine Parts
Center in Kaltenkirchen. ISO 9001
ISO 14001

Jungheinrich fork lift trucks meet
European safety requirements. 

**JUNGHEINRICH**