

ORBIT R



Rotating Ring Wrapper

Automatic rotating ring machine for spiral wrapping with stretch film.

*The ORBIT Range
is where two
technologies meet.*

The flexibility needed by high speed and high performance line machines becomes available on Entry Level horizontal machines to be added to work cells or integrated lines.

The machine is equipped with electro-welded mesh protections designed to ensure the safety of the operator during automatic operation of the machine itself.

Benefits:

- High programming flexibility
- Film saving
- Perfect packaging finish
- Customised configuration
- Ideal for large product size



ORBIT MODEL	R 5			R 9			R 13	
	125 single	250 single	250 double	125 single	250 single	250 double	250 single	250 double
Internal ring diameter	515mm			920mm			1330mm	
Variable rotating speed	20/180rpm	20/150rpm		10/120rpm	10/100rpm		10/80rpm	
Variable fed speed with inverter	5/20 n/min	8/35 n/min	15/70 n/min	4/15 n/min	5/25 n/min	10/50 n/min	4/20 n/min	8/40 n/min
Compressed air consumption	3.5 NI/cycle	5.5 NI/cycle	9 NI/cycle	13 NI/cycle	15 NI/cycle	18 NI/cycle	21 NI/cycle	25 NI/cycle
Power supply	400V 3Ph+N 50/60Hz			400V 3Ph+N 50/60Hz			400V 3Ph+N 50/60Hz	
Installed power	1.7 kW			1.7 kW			2.6 kW	
Total weight of machine	380kg	400kg	415kg	625kg	650kg	670kg	850kg	870kg
Pneumatic cold clamping / cutting unit	STD			STD			STD	
Clamping unit hot wire cutting (S.K.I.D.)	OPT		NA	OPT		NA	OPT	NA
Reel holder with fixed pre-stretch	OPT			OPT			OPT	
Max external diameter	230mm			250mm			250mm	
Reel internal diameter	76mm			76mm			76mm	
Reel height	125mm	250mm		125mm	250mm		250mm	
Film thickness	17/35µm			17/35µm			17/35µm	

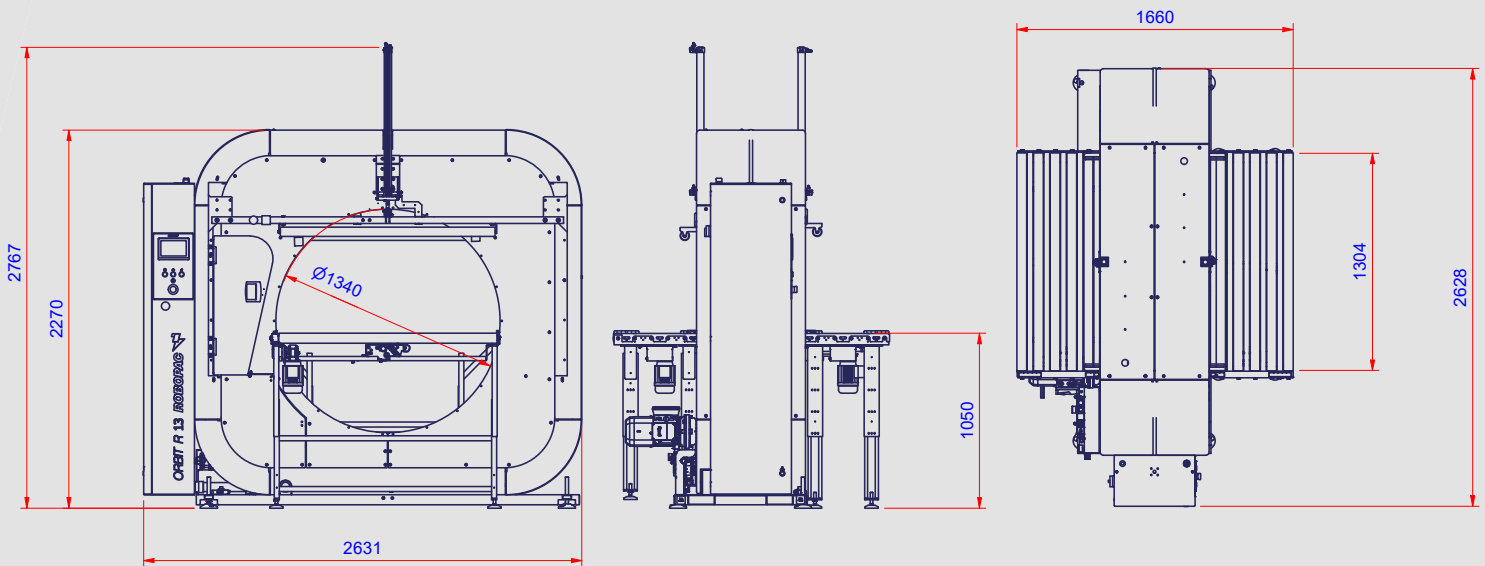

Robotic Automation p/l

14/4 Avenue of Americas
Newington, NSW 2127
Australia

Tel. 1300 552 333
sales@ragroup.com.au
www.ragroup.com.au