



# 800 SERIES FRYER

## 2 baskets

## FREI8/IDL – Electric

- High efficiency - all the energy goes into the oil
- Unique pan design maximises heat transfer to minimise energy use
- Digital thermostat
- Stainless Steel pan for easy cleaning
- Stainless Steel baskets
- Front cool zone with crumb arrester for longer oil life
- Cover/joiner strips available for multi-unit installations

### Other options

Night lid

Castors and tether

Cover/joiner strips

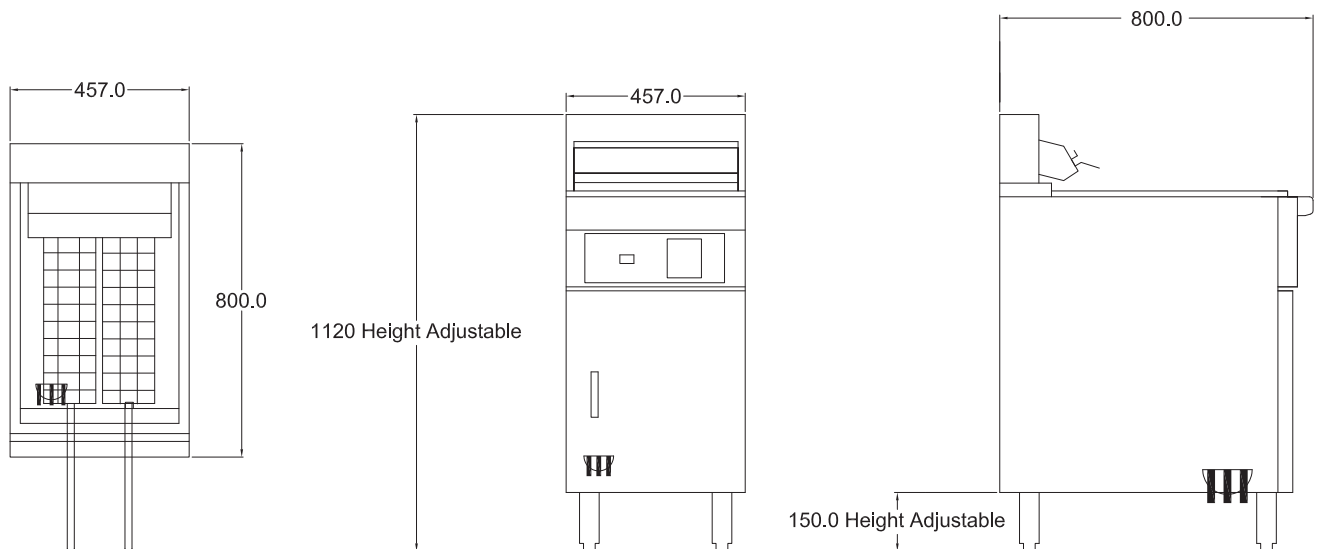

## FREI8/IDL

### SPECIFICATIONS

<b>Dimensions (WxDxH)</b>	457 x 800 x 1120 mm
<b>Working height</b>	900 mm (±20 mm)
<b>Pan Size (WxDxH)</b>	405 x 390 x 275 mm
<b>Capacity</b>	32 L

 3 Phase (415V+N+E) 7Kw/Ph

<b>Electric Connection</b>	3 phase, 415V+N+E
<b>Rating</b>	21 kW
<b>Weight</b>	65 kg
<b>Packed</b>	0.5 m <sup>3</sup>

Australia's premier food service  
equipment manufacturer

[goldstein.com.au](http://goldstein.com.au)

211-217 Woodpark Road, Smithfield NSW 2164  
1800 013 123 | +61 2 9604 7333

 **MIDDLEBY AUSTRALIA**

