

SureSWEEP

Operating manual (Translation of the original version)

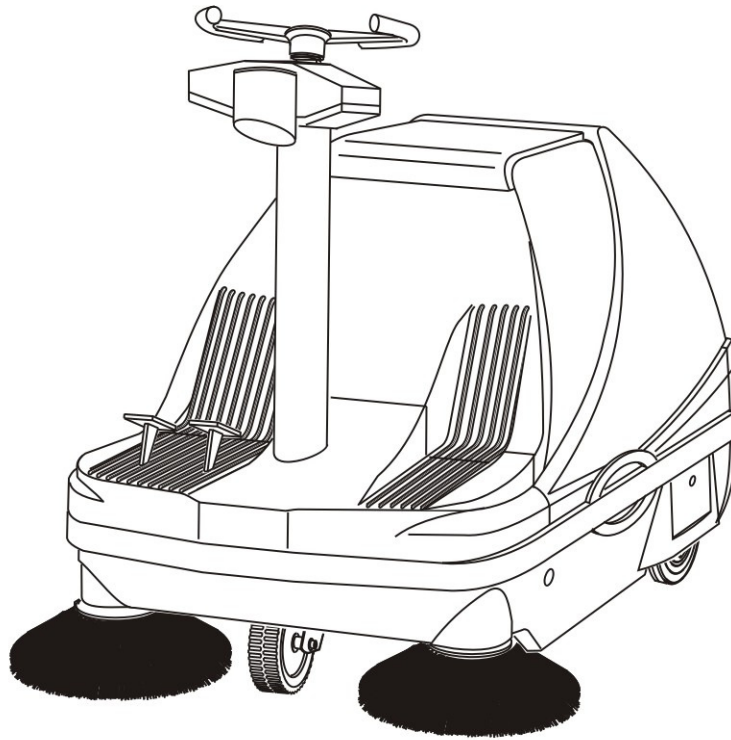

STR1000

Table of contents

1	Introduction.....	4
1.1	Usage conformant with intended purpose	4
2	Safety information.....	5
2.1	Safety Devices	6
3	Device Description.....	7
3.1	Device Description	7
3.2	Initial Startup	8
4	Operation.....	10
4.1	Driving	10
4.1.1	Forward motion:.....	11
4.1.2	Reverse motion:	11
4.1.3	Operating the Side Brushes	11
4.1.4	Stopping Side Brush Operating.....	11
4.2	Operatting the Sweeping Rollers	12
4.2.1	Stopping Sweeping Rollers Operation	12
4.3	operating levers	12
4.4	Battery.....	13
4.5	Turning Off the ride-on-suction-sweeper	13
4.6	Parking brake	14
4.6.1	Maintenance	14
4.7	Emptying the dustbin	14
4.7.1	Removing the dustbin.....	15
4.7.2	Inserting the dustbin	15
5	Maintenance.....	16
5.1	Safety Information.....	16
5.2	Cleaning.....	16
5.2.1	Operating the Filter Cleaning Device	16
5.3	Replacing the filter	17
5.3.1	Removing the filter.....	17
5.3.2	Fitting the filter	18
5.4	Sweeping Rollers Replacement.....	18
5.4.1	Dismounting the Sweeping Rollers	18

Table of contents

5.4.2	Installing the Sweeping Rollers	19
5.5	Chain drives	20
5.6	Removal of the cover	20
5.6.1	Taking off the cover	21
5.6.2	Mounting the cover	21
5.7	Lifting the hood front	21
5.7.1	Lifting the hood front.....	21
5.7.2	Mounting the hood front.....	22
5.7.3	Replacement of the hood front	22
5.8	Charging the Batteries	22
5.8.1	Operating the Ventilation Flap.....	23
5.9	Brake.....	23
5.9.1	Adjusting the Brake	24
5.9.2	Brake Check	24
5.10	Setting the Sweeping Rollers.....	25
5.10.2	Adjustment of the Side Brush.....	27
5.11	Replacing the Side Brush	28
5.11.1	Dismounting the Side Brush.....	28
5.11.2	Mounting the Side Brush	28
5.12	Overload safety cutouts	29
5.13	Maintenance Chart.....	30
5.13.1	After each 50 operating hours also	30
5.13.2	After each 100 operating hours also	30
5.13.3	After each 200 operating hours also	30
5.13.4	Disturbances - Disturbance Display and Remedy.....	31
5.14	Technical Data	32
5.15	Product Certification.....	33
5.16	Disposal	33
5.17	Accessories and spare parts	33
5.18	Service	34
5.19	Transport.....	34
6	EC Declaration of conformity (Translation of the original version).....	35

1 Introduction

This operating manual contains instructions for using the hand-operated sweeper.

Our products are subject to continuous improvement. Therefore, design changes that were made after this manual went to print could not be incorporated. If you have any questions, please contact our Service department.

The operating manual must be read and applied by all persons who operate the sweeper.

Apart from the operating manual and the regulations for accident prevention applicable in the country of use and the location of use, the common, recognised rules for safe and technically correct working must also be followed.

1.1 Usage conformant with intended purpose

The appliance is intended exclusively for sweeping on solid surfaces (for example.: parking areas, walkways, shop floors). The area to be swept should not be wet.

The sweeper may only be used by reliable and instructed personnel. Prevent children, juveniles and other unauthorised persons from using the machine (e.g. by pulling out the key after use).

Any other use, or any use over and above that, will be considered to be non-conformant with intended purpose. The manufacturer rejects any and all liability for damage resulting from such use. The risk is that of the user alone.

Usage conformant with intended purpose also includes compliance with the operating manual and the inspection and maintenance specifications. Drive the sweeper only along expressly marked routes and spaces.

2 Safety information

1. The machine should only be used in a flawless state, as well as in keeping with its intended purpose, in a safety-conscious and risk-conscious manner and in compliance with these operating instructions.
2. In addition to the operating manual, please heed general legal and other binding regulations for accident prevention and environmental protection.
3. Sweeping and picking up of flammable, toxic or explosive substances, along with flammable gases or diluted acids and solvents, burning or smouldering objects is prohibited!
4. The appliance is not suitable for picking up fluids, cables, cords, wires or the like.
5. The machine should only be used with the dust box fitted to prevent injuries caused by parts being slung out.
6. Transporting loads with the sweeper is not allowed.
7. Faults should be eliminated immediately, particularly those that could impair safety.
8. Do not make any changes, modifications or additions to the sweeper without the approval of the manufacturer.
9. Replacement parts must meet manufacturer specifications. This is always ensured by using original replacement parts.
10. Ensure that operating media, auxiliary media and replacement parts are disposed of in a safe and environmentally-friendly manner, particularly batteries!
11. Suitable non-slip footwear should be worn to avoid accidents.
12. If you have any questions, please contact our Service department.
13. Persons (including children) who are not able to use this machine safely due to their physical, sensory or mental capabilities or their inexperience or lack of knowledge may not use this machine without the supervision or instruction by a responsible person! Children should be supervised to ensure that they do not play with the appliance.
14. Caution: loose clothing can be caught and drawn in on rotating parts.
15. The operating instructions provided by the battery manufacturer relating to his product and legal specifications for the handling of accumulator batteries should be heeded!

16. Charge flat batteries directly after use and only in well-ventilated rooms.
17. Keep naked flames and electrical sparks away from the charging area, since a highly-explosive electrolytic gas mixture is generated when batteries are being charged.
18. Note that the accumulator batteries are filled with battery acid.
19. Batteries should always be kept clean and dry to avoid leakage currents! Never short-circuit battery poles!
20. Smoking, eating and drinking should be avoided in the vicinity of the battery charging station to avoid risks to health.
21. Batteries should only be charged with the hood opened and secured with the holder.

2.1 Safety Devices

The suction sweeper cannot be started unless:

- the key-operated switch is in the ON position (1);
- the main panelling has been closed properly.

The power supply to motor will be interrupted, if

- you open the main panelling;
- you turn the key-operated switch to the OFF (O) position.

3 Device Description

3.1 Device Description

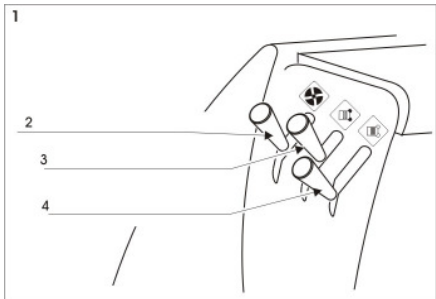

- 1 Operating lever
- 2 Lever for ventilator interruption
- 3 Lowering lever for side brushes
- 4 Lowering lever for sweeping rollers

An electric motor drives the ride-on-suction-sweeper which includes forward and reverse movement.

The sweeping mechanism of the Typ TT/E 1000 features two lateral brushes which carry the refuse to two sweeping rollers that are mounted parallel to the direction of motion.

These project the sweepings overhead into the dustcontainer positioned behind it.

A separate electric motor drives the roller brushes.

If necessary, the dust stirred up by the sweeping rollers is caught by the dust suction unit in a lamellar filterinside the machine.

The lamellar filter is cleaned by an electrically controlledfilter cleaning device.

If necessary the dust extraction can be closed off with a diaphragm to protect the filter from humidity.

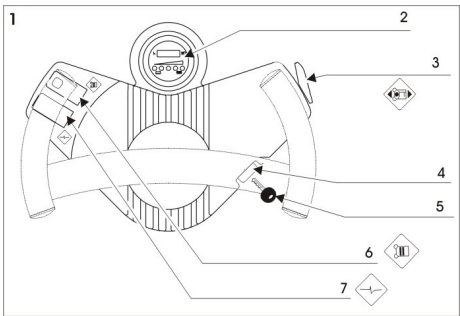

- 1 Dashboard
- 2 Battery condition display
- 3 Switch for the direction of motion
- 4 Key switch
- 5 Key
- 6 Switch for sweeping rollers
- 7 Button for filter shaker

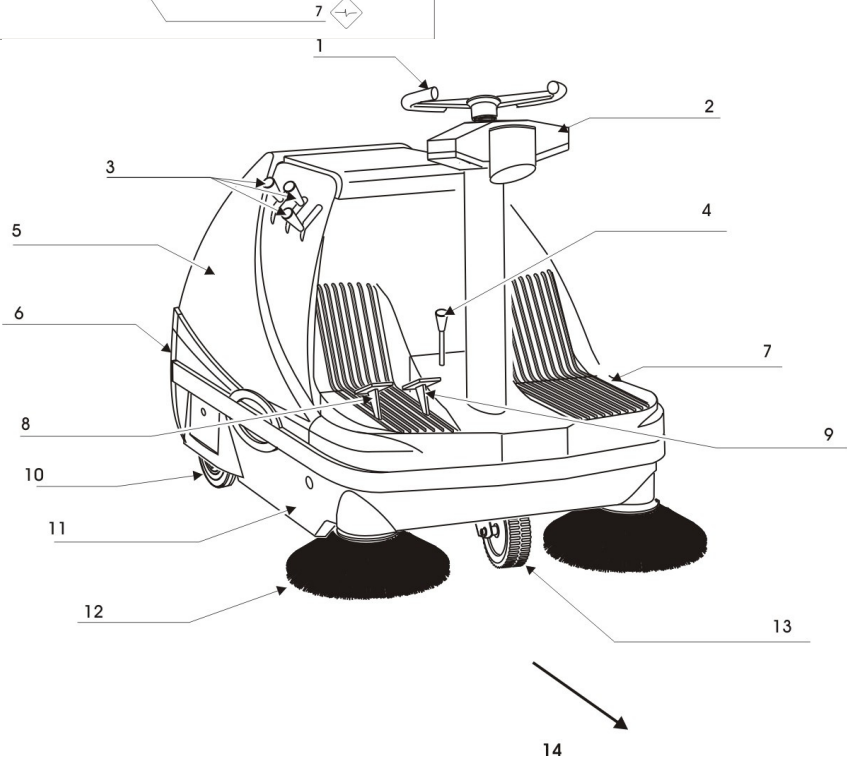

- 1 Steering wheel
- 2 Dashboard
- 3 Operating lever
- 4 Parking brake
- 5 Cover
- 6 Dust container
- 7 Hood front
- 8 Accelerator
- 9 Brake pedal
- 10 Driving wheel
- 11 Side trim panel
- 12 Side brushes
- 13 Steerable front wheel with drum break
- 14 Forward drive

3.2 Initial Startup

- The ride-on-suction-sweeper standard delivery is without batteries or charging device.
- Optional: the ride-on-suction-sweeper is supplied with batteries.

Standard:

- Open the transport packaging.
- Take off the cover.
- Fit in the batteries.
- Connect the batteries. (First positive pole, then negative pole!)
- Replace the cover.
- Mount the side brushes.
- The ride-on-suction-sweeper is ready for use.
- Drive the ride-on-suction-sweeper over a ramp out of the transport packaging.

ATTENTION

Use a unit ramp. The ramp must be designed in such a way as to allow the rear wheel as well as the drive wheels to travel across it.

If this is not observed, damages to the ride-on-suction-sweeper mechanics will occur!

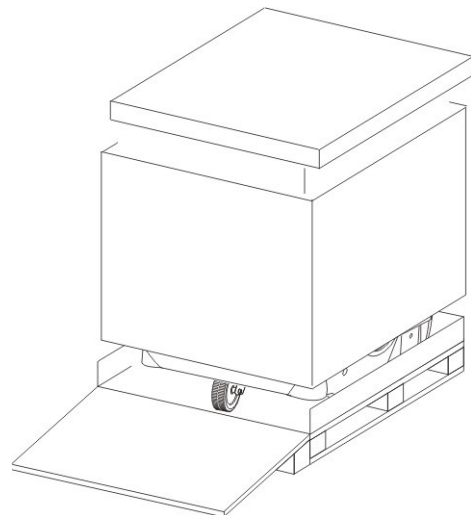

Optional:

- The ride-on-suction-sweeper is equipped with batteries.
- Open the transport packaging.
- Take off the cover.
- Connect the positive pole of the battery.

- Replace the cover.
- Mount the side brushes.

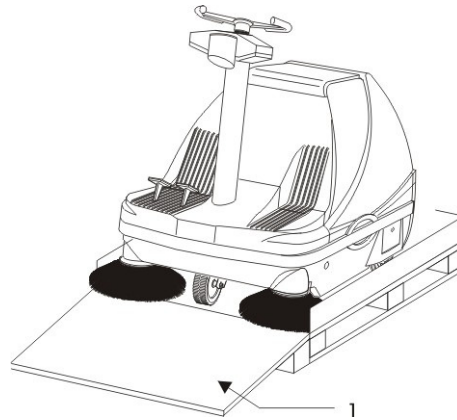

- 1 Unit Ramp
- Drive the ride-on-suction-sweeper over a ramp out of the transport packaging.
 - The ride-on-suction-sweeper is ready for use.

4 Operation

4.1 Driving

- Starting the ride-on-suction-sweeper
- Sit down in the driver`s seat

If the main casing is not fitted correctly, the machine will be inoperative.

Check the operational reliability of the brake before every run!

Check position of direction of motion switch.

For starting the motor the switch must be in neutral position.

The direction of motion switch is a toggle switch with three positions.

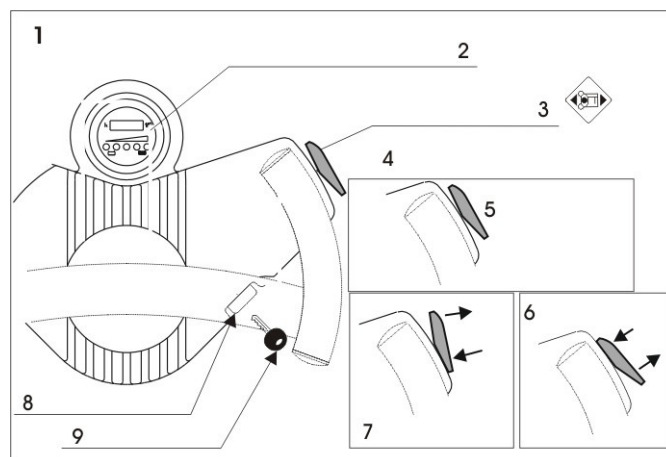

- | | |
|--------------------------------|-----------------------------|
| 1 Dashboard | 2 Battery condition display |
| 3 Switch for the direct motion | 4 Switch position |
| 5 Neutral position | 6 Reverse motion |
| 7 Forward motion | 8 Key switch |
| 9 Key | |

- Depress the brake pedal.
- Insert the key into the key switch.
- Turn the key clockwise.
- On the control panel a red LED starts flashing. (This indicates machine ready for operation.) After that the LED's indicating the battery's charging condition light up.

DANGER!



To avoid accidents, make sure that nobody is right next to, in front of, or behind the ride-on-suction-sweeper.!

- Release the parking brake.
- Actuate the direction of motion switch.
- Take your foot off the brake pedal.

4.1.1 Forward motion:

- Push the direction of motion switch forward. Optical signal:
- Green pilot lamp on the switch
- The ride-on-suction-sweeper moves forward.

4.1.2 Reverse motion:

- Push the direction of motion switch backward.
- The ride-on-suction-sweeper moves backward.

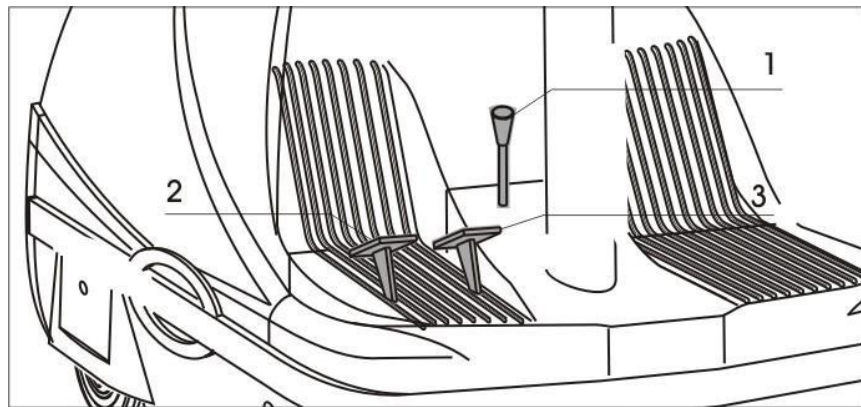

1 Parking brake
2 Accelerator pedal
3 Brake pedal

- The speed of the ride-on-suction-sweeper can be adjusted with infinite variability by depressing the accelerator.

4.1.3 Operating the Side Brushes

- Start the ride-on-suction-sweeper.
- Switch the toggle switch for the sweeping rollers to "ON" position.
- Unlatch the lowering lever of the side brushes.
- Push the lever down.

4.1.4 Stopping Side Brush Operating.

- Pull up the lowering lever for the side brushes.
- Let the lever snap in arresting position.
- Switch toggle switch for the sweeping rollers to "OFF" position

4.2 Operatting the Sweeping Rollers

- Start the ride-on-suction-sweeper.
- Unlatch the lowering lever of the sweeping roller.
- Push down the lowering lever.
- Switch the toggle switch for the sweeping rollers to "ON" position.

4.2.1 Stopping Sweeping Rollers Operation

- Switch toggle switch for the sweeping rollers to "OFF" position
- Lift the sweeping rollers and arrest the lowering lever of the sweeping rollers.
- Let the lever snap in arresting position.

4.3 operating levers

The operating levers are controlled from a gear shifting gate. The operating levers can be arrested in upper position.

For lowering the, first lift the lever a little, then push it to the back and press it down.

For lifting the operating levers, pull up the lever from the lower position, and then pull it to the front. The operating lever remains in this position.

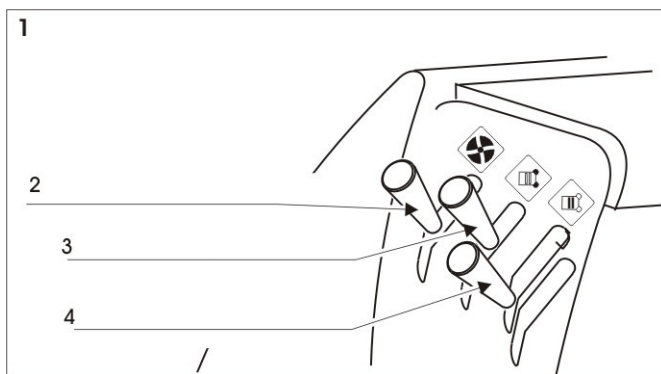

- 1 Operating lever
- 2 Lever for ventilator interruption
- 3 Lowering lever for side brushes
- 4 Lowering lever for sweeping rollers

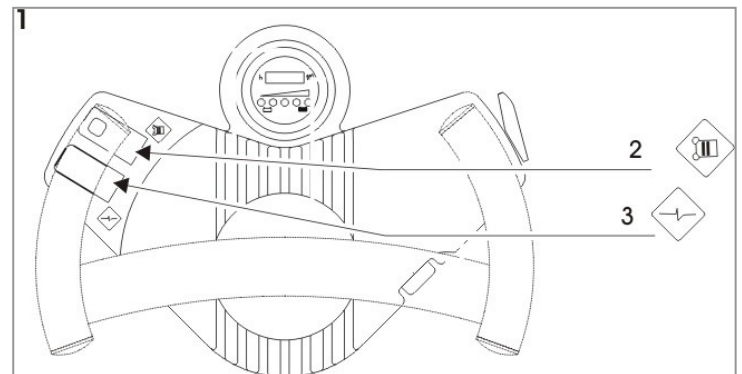

- 1 Dashboard
- 2 Switch for sweeping rollers
- 3 Button for filtershaker

4.4 Battery

Two batteries supply the suction sweeper with electricity.

The charging condition of the batteries is indicated by the battery condition display on the control panel.

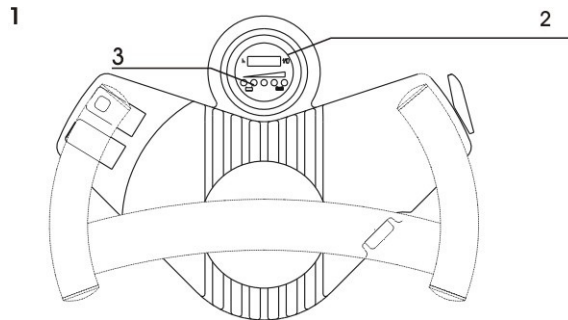

- 1 Dashboard
- 2 battery condition display
- 3 LED`s

When the ride-on-suction-sweeper is switched on the red LED flashes five times. Subsequently the electronic system of the ride-on-suction-sweeper carries out a self-testing operation of the battery charging state.

The result of this self-testing is displayed by the 5 LED`s.

Information provided by LED indicators on the battery condition display:

lit LED	charging condition of battery
Red Yellow Green Green Green	
☀ ☀ ☀ ☀ ☀	condition fully charged
☀ ☀ ☀ ☀ ○	operating/charging condition uncritical
☀ ☀ ☀ ○ ○	operating/only for a short time longer
☀ ☀ ○ ○ ○	operating/soon critical
☀ ○ ○ ○ ○	operating/critical

4.5 Turning Off the ride-on-suction-sweeper

CAUTION!



Make sure the suction sweeper is on level ground when you loosen the parking brake, or secure the suction sweeper to prevent accidental rolling!

- Depress the brake pedal.
- Lock the brake by pulling the locking lever towards the driver's seat.

When the brake now is relieved the brake pedal must remain in depressed position.

- Set position of direction of motion switch to neutral position.

Medium position: All of the pilot lamps on the switch are off.

- Switch off all actuators.
- Lift up the side brushes and arrest the lowering lever for the side brushes.
- Lift up the sweeping rollers and arrest the lowering lever for the sweeping rollers.
- Turn the key counterclockwise and remove it from the key switch.

4.6 Parking brake

Use the hand brake lever to engage the parking brake. If the brake is engaged and you pull up the hand brake lever, the locking slide will be drawn below the bottom side of the brake pedal, and it will hold the brake pedal in its position, and thus effect the front wheel.

If you press down the hand brake lever, the locking slide will release the brake again.

4.6.1 Maintenance

- Lift the hood front.
- Grease the movable parts of the parking brake every 100 running hours.

4.7 Emptying the dustbin

Refuse is collected in the dustbin.

This is located at the rear of the suction sweeper.

The dustbin must be emptied regularly, and at least each time the sweeper is used.

4.7.1 Removing the dustbin

- Pull the Dustbin arrest off the holding knobs on both sides
- Pull the dustbin out of the suction sweeper by the handle until the front dustbin guides are free.

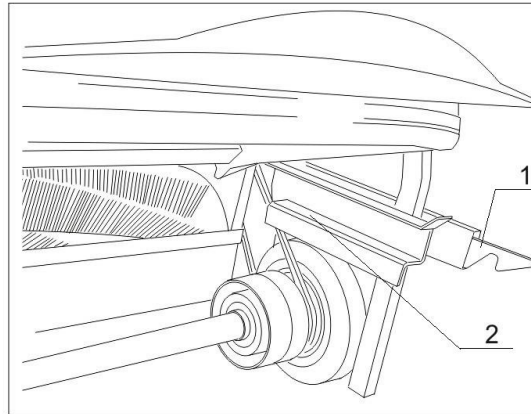

1 Dustbin arrest

2 Dustbin guide rail

There are two guide rollers at the rear end of the dustbin to facilitate its removal.

- Lower the dustbin to the ground.

Underneath the dustbin are guide rollers and a recessed grip.

- Pull the dustbin fully out of the suction sweeper.

To empty the dustbin, insert your other hand into the recessed grip.

Refuse is emptied out via the lower edge of the dustbin dirt collector.

- Empty the refuse into an appropriate container only.

4.7.2 Inserting the dustbin

- Place the dustbin in front of the dustbin mount.
- Raise the front dustbin guides to the height of the guide rails.
- Push the dustbin into the suction sweeper.

5 Maintenance

5.1 Safety Information

Only complete the type of maintenance work described in the following chapter. All other maintenance and upkeep work may only be carried out by the manufacturer or by companies and persons authorised by the manufacturer, who are familiar with the relevant safety specifications, because portable devices in industrial use are subject to the safety test according to VDE 0701.

Closely follow the steps listed in the maintenance instructions. The improper completion of maintenance tasks may result in malfunctions when using the sweeper and may possibly render the warranty granted null and void.

When working on the electrical system, the battery should be disconnected.

Maintenance work/ troubleshooting at the electric motor must not be done while the electric motor is running.

Use only flawless and appropriate tools to complete maintenance work.

Note the requirements for spare parts.

If covers and/or safety devices were removed during maintenance work/repairs, they will have to be reattached prior to starting the sweeper.

For carrying out any work on the sweeper, it must be switched off and secured from rolling away by accident.

5.2 Cleaning

The suction sweeper may only be cleaned in the off state, when it is dry.

The suction sweeper is a machine with electrical components.

WARNING



Moisture damages the electronics of the device. Moisture can result in leakage currents and short-circuits.!

Do not use any high-pressure cleaners

5.2.1 Operating the Filter Cleaning Device

The filter cleaning device prevents the lamellar filter from being blocked by debris.

- Switch off suction.
- Wait until ventilation wheel stands still.

- Apply filter cleaning device at regular intervals.
- Depress the toggle switch for the filter cleaning device for about 5 to 10 seconds.

Safety Information

5.3 Replacing the filter

The filter serves to separate off fine dust.

The filter is cleaned mechanically by the filter vibrator.

5.3.1 Removing the filter

- Shut down the suction sweeper, as described.
- Remove the dustbin from the machine
- Remove the hood.
- The filter is positioned on a frame.
- Hold the filter frame in position with one hand.
- Press the clips of the tension closures downwards.
- Release the threaded hooks from the filter frame arrests.
- Remove the frame with the filter in a downwards direction.
- Remove the filter from the frame.

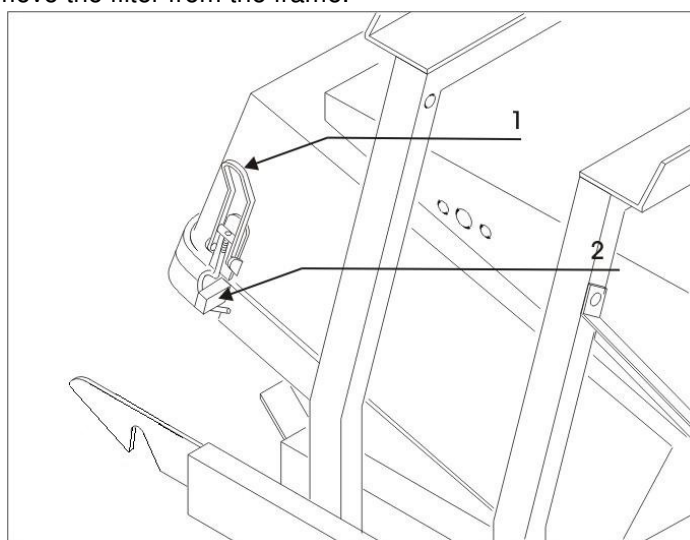

1 Tension closure

2 Filter frame arrest

5.3.2 Fitting the filter

- Place the filter on the frame.
- Fold the frame upwards.
- Push the threaded hooks over the filter frame arrests.
- Press the clips of the tension closures upwards.
- Push the dustbin back into the machine.

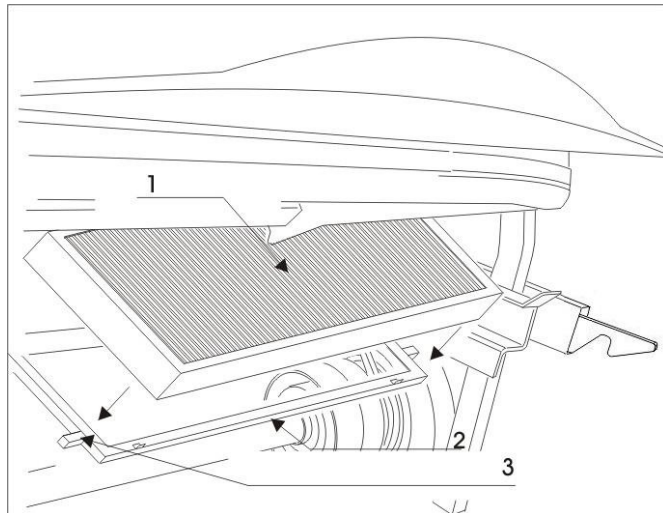

- 1 Filter
2 Filter frame
3 Filter frame arrest

5.4 Sweeping Rollers Replacement

5.4.1 Dismounting the Sweeping Rollers

- Park the suction sweeper as described.
- Take the key out of the key-operated switch.
- Pull lowering lever of the sweeping rollers.
- Arrest the lowering lever.
- Loosen the bolts of the left side trim panel facing in driving direction.
- Remove the side panel.

The roller swing is held in place by three star handles.

- Loosen the star handles.
- Remove the roller swing.

Pull the sweeping rollers out of the machine and remove any debris, cords, etc., from the roller tunnel and from the pick-up pins.



1 fastening bolts of side trim panel

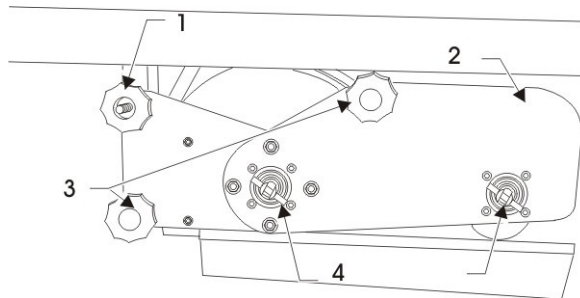

1 open star handle
3 turning lever

2 star handle
4 turning lever

5.4.2 Installing the Sweeping Rollers

- Push the sweeping rollers under the machine.

Observe the sweeping rollers' sense of rotation while sliding them in.

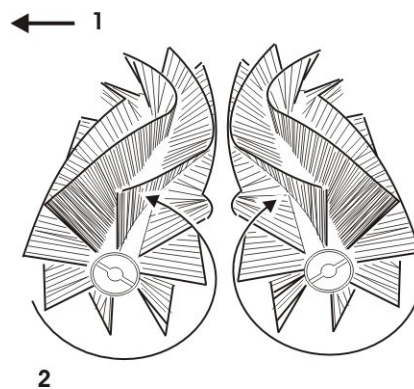

1 forward drive

2 Direction of motion of the sweeping rollers

Each roller end is equipped with a keyway.

- Turn the sweeping roller until the pick-up pin of the rear roller swing fits into the keyway of the sweeping roller.
- Slide the sweeping rollers in as far as possible.
- Set the front roller swing onto the free sweeping roller ends.

The roller swing is equipped with two turning levers.

Each turning lever end is equipped with one pick-up pin.

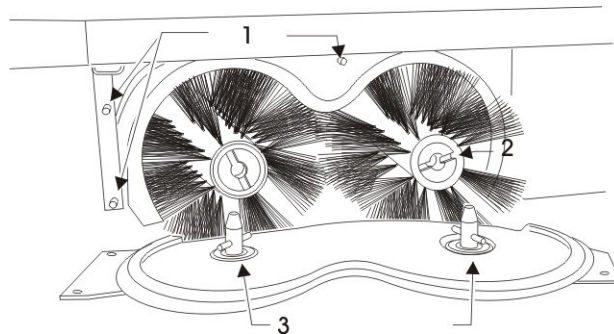

- 1 sweeping roller keyway 2 sweeping roller keyway
3 pick-up pin

- Turn the turning lever until the pick-up pin fits into the keyway of the sweeping rollers.
- Push the roller swing over the threaded rods.
- Make sure the sweeping rollers are fitted on both sides by the keyway into the pick-up pins and that all star handles are firmly tightened.
- Fasten the side trim panel.

5.5 Chain drives

One electric motor each drives the travelling mechanism and the driving mechanism of the sweeping rollers via chains.

Both chain drives are, when seen in direction of motion, located on the right side of the ride-on-suction-sweeper.

Grease the chain wheels at regular intervals. See maintenance schedule

To grease the chain wheels, take off the cover and remove the side panel.

5.6 Removal of the cover

You can remove the cover of the ride-on-suction-sweeper to perform maintenance and repair work.

5.6.1 Taking off the cover

To remove the cover, please proceed as follows:

- Remove the key out of the key-operated switch.
- Reach below the driver's seat and grasp the rear edge of the cover.
- Lift the cover at the rear.
- Lift the complete cover.
- Remove the cover.

5.6.2 Mounting the cover

To mount the cover, please proceed as follows:

Reach below the driver's seat and grasp the rear edge of the cover.

Lift the cover.

Place the cover on the ride-on-suction-sweeper.

Make sure that the front edge of the cover lies on the keep-off plate.

Make sure that the lateral guiding pins of the cover are fitted correctly in the frame.

If the cover is not fitted correctly, the machine will not run.

5.7 Lifting the hood front

You can lift the hood front for maintenance and repair work.

5.7.1 Lifting the hood front

To lift the hood front part, please proceed as follows:

- Pull the key out of the key-operated switch.
- Remove the knob of the parking brake.
- Unscrew the upper parts of the brake pedal and the accelerator pedal.
- Lift the complete hood front.
- Secure the hood front against falling down by tying it to the steering wheel.

5.7.2 Mounting the hood front

To mount the hood front, please proceed as follows:

- Loosen the fastening between the hood front and the steering wheel.
- Direct the hood front along the steering rod towards the bottom.
- Fit the hood front tightly into the machine frame.

Make sure the rear edge of the casing lies on the keep-off plate.

- Assemble the upper parts of the brake and accelerator pedal.

Make sure that the upper parts fit correctly. Assemble the upper parts in such a way that the accelerator pedal will be directed away from the steering column and the brake pedal will be directed towards the steering column.

- Assemble the knob of the hand brake.

5.7.3 Replacement of the hood front

Please contact your specialist dealer

5.8 Charging the Batteries

- Turn off the ride-on-suction-sweeper.
- Open the hood.
- Secure the hood position by the hood arresting device.
- Pull apart the red main battery connector.
- Connect the loading device to the loose loading plug of the suction sweeper.
- Connect the mains plug of the charging device to a power supply socket.

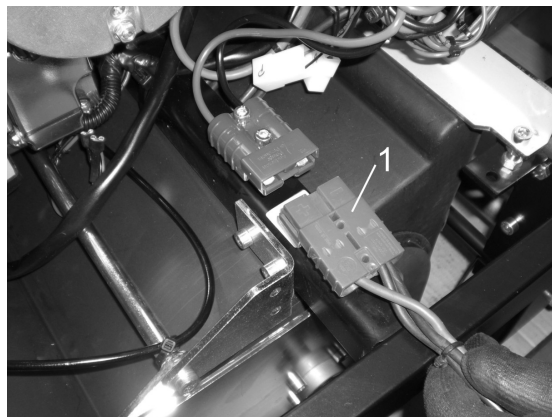

1 loading plug of the suction sweeper

When the charger supplied is used, a green control lamp serves to indicate that charging is complete.

The machine takes approx. 10 hours to charge fully (with the manufacturer's original accessories charger).

The manufacturer's original charger can/should remain connected after charging, as it has a trickle charge function, and thus ensures maximum battery capacity even after long standing times.

Ensure that the suction sweeper is only started up if there is sufficient charge left in the batteries.

The machine automatically switches off if the batteries are discharged to such an extent that damage could occur (discharge protection).

5.8.1 Operating the Ventilation Flap

The purpose of the ventilation flap is to protect the machine when sweeping moist surfaces.

- If the ventilation is on, the dust extraction will be turned off.
- To turn on the ventilation, pull the lever of the ventilation flap upwards.

If you want to sweep on a dry surface again, you will have to push down the lever down.

If you are sweeping a dry surface and the sweeping performance is poor or a lot of dust swirls up, you will have to check the position of the lever for the ventilation flap.

5.9 Brake

DANGER!



The brake is a component affecting operational safety.

All work pertaining to the maintenance and replacement of brake parts must be executed by professionally trained personnel.!

The brake (drum brake) acts on the rear wheel and is controlled via Bowden pull wire by the brake pedal.

The brake adjustment is situated on the right side of the rear wheel facing in driving direction.

5.9.1 Adjusting the Brake

- Hold the adjustment nut of the Bowden pull wire in place with a wrench.
- Loosen the back nut of the Bowden pull wire.
- Push the brake lever upward until the brake lever is obstructed.
- Hold the brake lever in this position.
- Tighten the back nut of the Bowden pull wire.

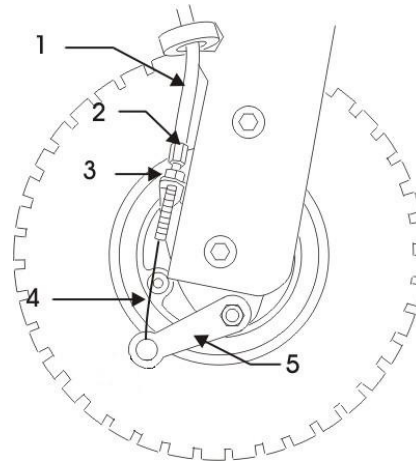

- | | |
|----------------|------------------|
| 1 Bowden cable | 2 adjustment nut |
| 3 back nut | 4 brake pulley |
| 5 brake pulley | |

Now conduct a brake check.

5.9.2 Brake Check

Free Movement of Rear Wheel

You must be able to move the ride-on-suction-sweeper by pushing when the brake is released. The rear wheel must not be blocked. Brakes that are set too tightly damage the brake drum.

Correct Operating of Brake

Carefully drive a few meters at moderate speed.

Depress the brake pedal. The ride-on-suction-sweeper must stop.

If the brake check should not render a satisfying result the setting procedure must be repeated.

Further Setting Possibility:

The Bowden pull wire does not allow tightening in the way described above any longer.

- Loosen the brake pulley arresting.
- Lift the brake lever up until it is obstructed.

- Hold the brake lever in this position.
- Pull the brake pulley down and push the brake pulley arresting upward.
- Fasten the brake pulley arresting.
- Carry out the above described brake check.

Check the operational reliability of the parking brake

- Engage the brake pedal.
- Engage the parking brake.
- Take your foot off the brake pedal.
- The brake pedal must remain in its position.
- When pushing by hand, the ride-on-suction-sweeper must not move.

5.10 Setting the Sweeping Rollers

Sweeping Contour Adjustment

For best cleaning results and to ensure the highest possible device efficiency, the sweeping rollers are equipped with a sweeping contour. The sweeping contour should be set to approx. 30-40 mm at the rear roller.

Establishing the Sweeping Contour:

- Drive the ride-on-suction-sweeper to an area to be cleaned.
- Switch on the sweeping rollers without moving the sweeping machine.
- Allow the sweeping rollers to run for about one or two minutes without moving.
- Lift the sweeping rollers.
- Stop sweeping rollers operation and drive forward a few meters.
- The sweeping track visible on the ground is the sweeping contour.

Adjusting the Sweeping Contour

- Park the suction sweeper as described.
- Take the key out of the key-operated switch.
- Lift the sweeping rollers and arrest the lowering lever of the sweeping rollers
- Let the lever snap in arresting position.
- Open the hood.
- Secure the hood position by the hood arresting device.

- Remove the right side trim panel facing in the direction of motion.

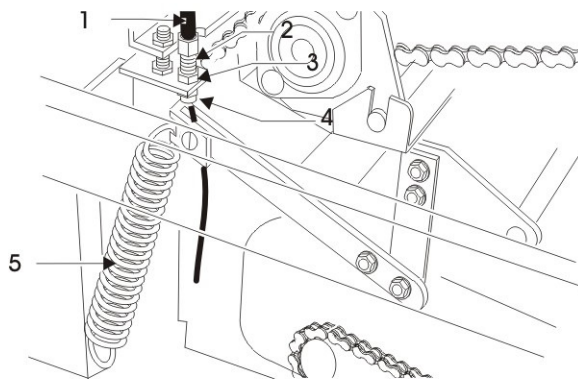

- | | |
|--------------------|-----------------|
| 1 Bowden pull wire | 2 threading rod |
| 3 counter nut A | 4 counter nut B |
| 5 spring | |

Increasing the Sweeping Contour by Lowering Sweeping Rollers

- Loosen counter nut A on the threading rod of the Bowden pull wire.
- Turn counter nut A counterclockwise.
- Now lock counter nut A in place by counter nut B.

Decreasing Sweeping Contour by Lifting Sweeping Rollers

- Loosen counter nut B
- Turn counter nut B clockwise by a few more threads.
- Lock counter nut B in position by counter nut A.

ATTENTION!



The sweeping rollers are pendulous and adapt to uneven surfaces up to a certain degree. They are put into operating position by means of the rotation only. Only the tips of the brushes will touch the ground when lowering the device during standstill. That is why force on the sweeping roller lever will only be exerted when the brushes are rotating.!

Further Possible Adjustment:

- Park the suction sweeper as described. Take the key out of the key-operated switch.
- Lift the sweeping rollers and arrest the lowering lever of the sweeping rollers
- Let the lever snap in arresting position.
- Open the hood.
- Secure the hood position by the hood arresting device.
- Remove the right side trim panel facing in the direction of motion.
- Loosen the holding screw.

- Move sweeping roller retaining to desired position.
- Tighten up the holding screw again and mount the side trim panel.

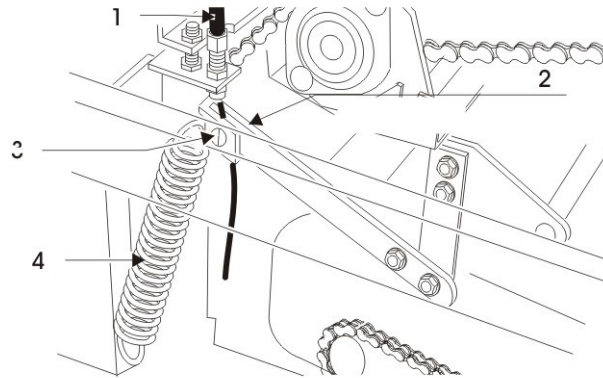

- | | |
|--------------------|-----------------|
| 1 Bowden pull wire | 2 holding screw |
| 3 spring | 4 spring |

Original roller diameter: 230 mm.

When diameter has decreased to 200 mm, the roller needs to be replaced.

5.10.2 Adjustment of the Side Brush

Operational wear necessitates additional adjustment of the side brushes.

- Park the suction sweeper as described.
- Take the key out of the key-operated switch.
- Unlatch the lowering lever of the side brushes.
- Push down the lowering lever.
- Remove the entire main panelling.

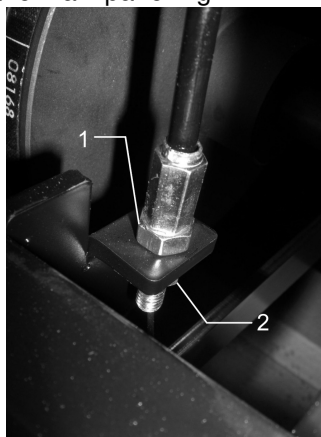

- | | |
|---|------------|
| 1 Screw of the height-adjustment of the lateral brushes | 2 Back nut |
|---|------------|

- Loosen the back nut.
- To lower the lateral brush, you will have to turn the screw of the height-adjustment of the lateral brushes clockwise.
- To raise the lateral brushes, you will have to turn the screw of the height-adjustment of the lateral brushes counterclockwise.
- Set the lateral brushes to their desired position.
- Tighten the back nuts. Put on the main panelling.

5.11 Replacing the Side Brush

5.11.1 Dismounting the Side Brush

- Park the suction sweeper as described.
- Take the key out of the key-operated switch.
- Pull up the lowering lever for the side brushes.
- Arrest the lowering lever.
- Pull off the spring plug from the axle of the lateral brushes.

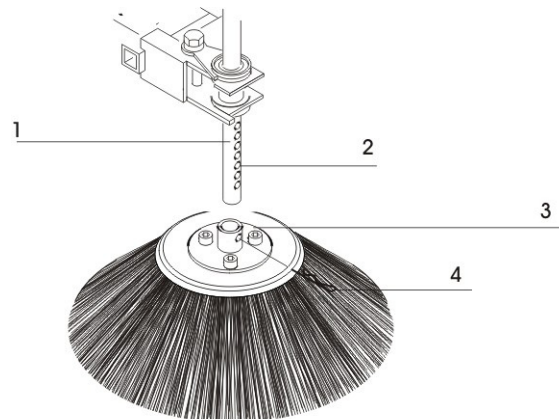

- | | |
|---------------------------------|---------------|
| 1 Borehole | 2 Borehole |
| 3 Flange of the lateral brushes | 4 Spring plug |

- Pull the side brush down and off.
- Replace the side brush.

5.11.2 Mounting the Side Brush

- Fasten the flange plate to the side brush.
- Push the lateral brush on the axle of the lateral brushes.
- Push the spring plug through the borholes of the lateral brush flange plate and through the borehole of the axle of the lateral brushes (until ground contact).

5.12 Overload safety cutouts

When seen in direction of motion the overload safety cutouts are located on the left, below the rear cover, and protect the electric motors against overload.

If an overload safety cutout responds, the respective electric motor will not run:

- Switch off the ride-on-suction-sweeper.
- Wait for some minutes.
- When seen in direction of motion, lift up the left side of the back of the hood.
- Secure the back of the hood just lifted with the hood locking device.
- Press in the pin of the triggered safety fuse.
- Close the back of the hood.
- Start the ride-on-suction-sweeper.
- Check for proper functioning of the respective electric motor.

If the overload safety cutout responds again, switch off the ride-on-suction-sweeper and eliminate the fault that caused the overload safety cutout to respond. (See chart - malfunctions -)

DANGER



Do not repair any fuse.

Do not replace any fuse by a stronger one.

Do not bridge any fuse.

This will lead to damages to the electrical installation.

Consequently a short circuit might occur, even lead to a fire!

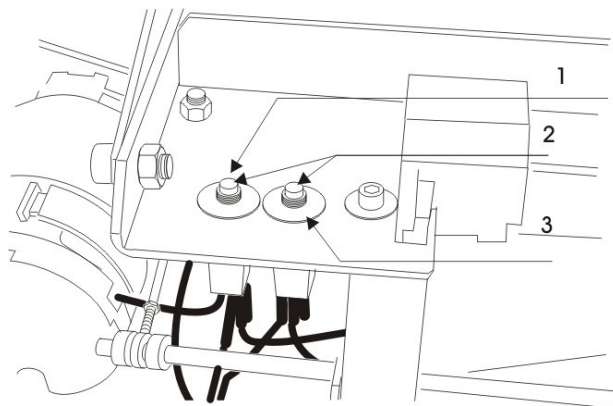

1 Overload safety cutout -
travelling mechanism

2 Locking pins

3 Overload safety cutout -
brush driving mechanism

5.13 Maintenance Chart

- Daily maintenance
- Check battery acid level, if required replenish distilled water.
- Charge battery.
- Check if machine is damaged or impaired in any way.
- Check condition of dust filter and clean if necessary.
- Empty dust container.
- Search brush - roller tunnel for jammed particles and seized up dirt that may narrow the brush tunnel and obstruct free roller brush movement.

5.13.1 After each 50 operating hours also

- Check if battery leaks acid.
- Clean and grease battery poles.
- Check if sweeping rollers are worn or cluttered. Replace if required.
- Check sweeping contour, readjust if required.
- Check if side brush adjustment is worn, if required readjust or replace.
- Cleaning the frictional wheel and the driving belt (with nitro-thinner, benzene or brake cleaner)

5.13.2 After each 100 operating hours also

- Check cable isolation, replace cables if required.
- Check if cable connections are tight.
- Clean dust filter, replace if necessary.
- Search suction for obstacles, clean.
- Conduct trial run to check all operating elements.
- Check if roller drive chain is elongated or loosened.
- Check all bearings for wear.

5.13.3 After each 200 operating hours also

- Check operation of electric motor.
- Check if carbon brushes are worn, replace if required.

5.13.4 Disturbances - Disturbance Display and Remedy

Disturbance	Possible Cause	Remedy
No operating display at control panel	Key switch not switched on	Turn key switch and check correct load
	Hood contactor not actuated	Check the fit of the main paneling.
	Fault in electrical wiring	Check plug connections
	Battery empty	Charge battery
Sweeping result unsatisfactory:	Side brush(es) or main sweeping rollers not lowered	Lower
	Side brush(es) or main sweeping rollers worn	Adjust
	Trajectory clogged by dirt	Check if roller trim panel is impaired by jammed debris.
	Sweeping roller(s) do not operate	Correctly fitted?
	Dust formation too great	Does motor revolve? if required switch off side brushes
	Filter heavily polluted	Open the ventilation flap
	Filter not correctly fitted	Clean filter
	Leakage and subsequent aspiration of	check for tight fit
	false air in the filter chamber	check if false air is sucked in
	Brush rollers are jammed by dirt, cords, strings or the like	Dismount brush rollers and clean them
	Side brushes are jammed by dirt, cords, strings or the like	Check side brushes and remove obstacles
	Ator does not move freely	Check ventilator wheel and remove any obstruction
	Drive wheels obstructed	Jack up the Sweeping & Suction Machine check differential operation of wheels and free running
Safety fuse was triggered	Safety fuse was triggered	Check and eliminate the cause. Re-install the fuse
It does not move	The control device does not function	See above

Maintenance

Disturbance	Possible Cause	Remedy
	Fault in the control system of the travelling mechanism	Check, replace if necessary
		Check and eliminate the cause.
	Safety fuse was triggered	Re-install the fuse
	Parking brake has got stuck	Loosen

5.14 Technical Data

Dimensions and Weight	
Length	1190 mm
Height	1089 mm (upper edge of steering wheel)
Weight:	
without batteries	140,0 kg
with batteries	160,0 kg
Sweeping Width:	
Main sweeping roller	600 mm
with one side brush	800 mm
with two side brushes	1000 mm
Dust Container Volume	70 ltr
Climbing Capacity:	20%
Speed:	
Forward movement	0-6 km/h
Moving backwardst	0-2,5 km/h
Filter Area:	3 m ²
Volume flow turbine:	600 m ³ / 200 pa
supporting frame :	Steel construction, powder coated
Trim Panel Parts:	impact resistant plastic

Electrical Installation	
Power supply	2 x 12 V Batterie, 60 - 80 Ah K5
Running time of battery version:	ca. 2,5 - 3 h

Brake	
Drum brake	Acting on front wheel
Parking brake	

Maximum Airborne Sound Level	dB (A):82 dB(A)
Weighted Effective Acceleration Value upper extremities are subjected to	<2,5m/s ²

5.15 Product Certification



5.16 Disposal

Dispose of faulty parts, especially electrical components, batteries and plastic parts according to the locally applicable waste disposal specifications.

Used batteries must be disposed of according to Directive 2006/66/EC.

5.17 Accessories and spare parts

Accessories and spare parts must conform to the requirements of the manufacturer. This is ensured by using genuine replacement parts.