

ILERPAL L Layer Pressing Palletizer Automatic Hybrid Palletizer

BENEFITS

- Open-mouth bag overlapping
- Optimal pallet finishes
- Energy savings
- Component savings
- Gentle, quiet, precise palletising
- Flexible, quick format changes
- Optimised plant space
- Versatility for handling a wide range of formats
- Easy maintenance as all moving parts is at ground level

5-sided layer pressing done properly! The ILERPAL L palletizer is the industry's new leading solution for perfect pallet stacks. This highly versatile system has applications across a wide range of industries including seed, grain, stockfeed, fertilizer, ingredients and more. '

New design solves lifting mechanism issues experienced with other brands. It is fully supported across Australian and New Zealand by trained technicians. The ILERPAL L offers a flexible design that pick off pallet conveyors or off stationary platform.

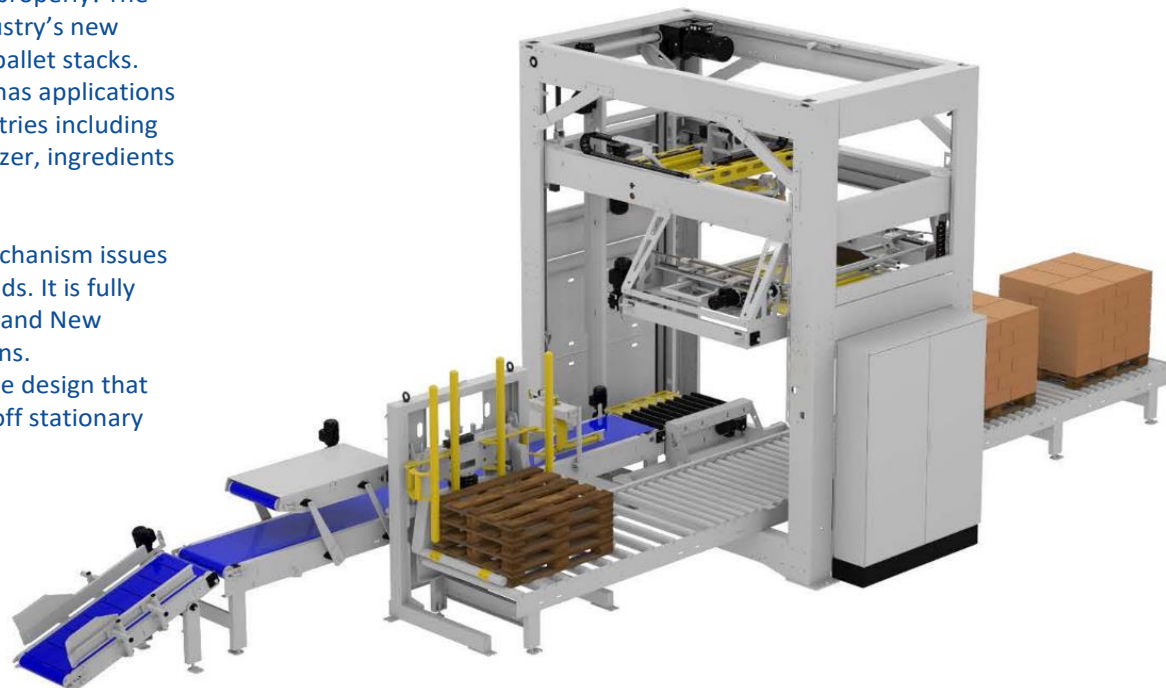

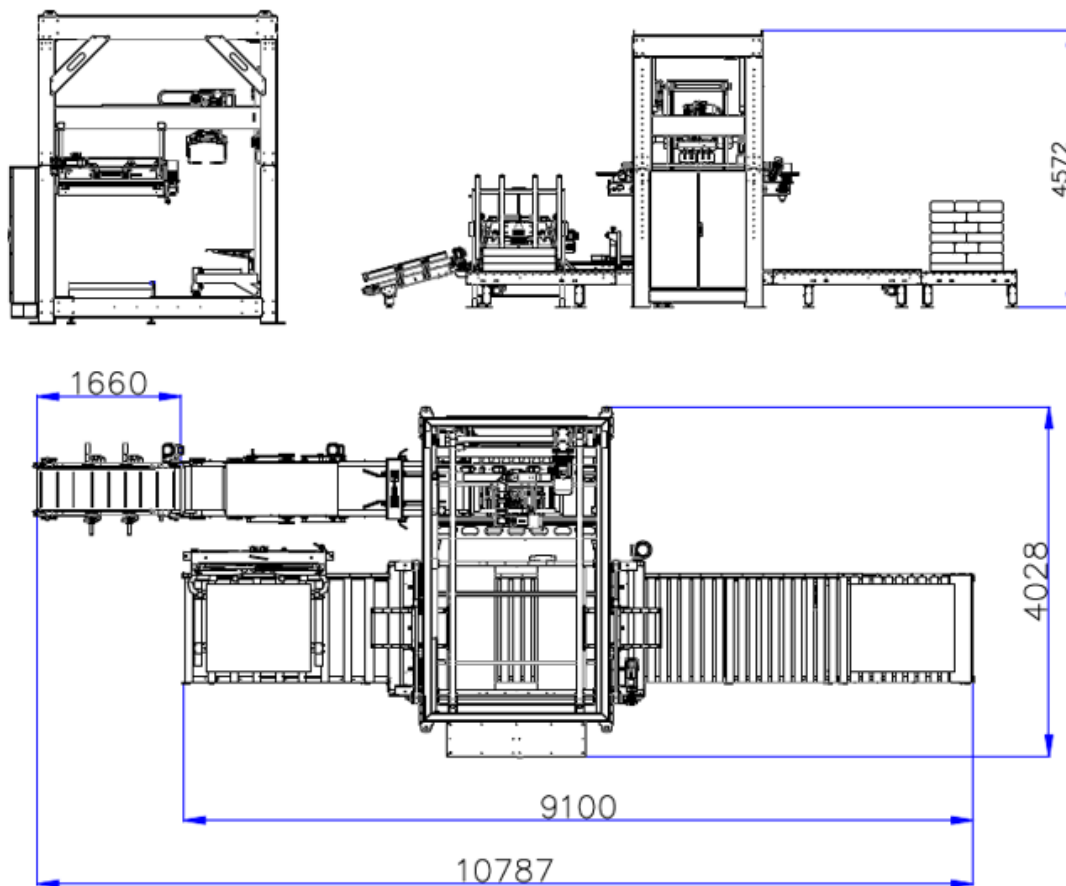

Diagram dimensions are for reference only*

SPECIFICATIONS	
VOLTAGE	380 III N+T 50 Hz
CONTROL VOLTAGE	24V
POWER:	28 Kw
PRESSURE	6 bar
CONSUMPTION	400 NL/min