

VT-950/1150

Large Size Vertical Turning Center
Built in Gear Box with 24" – 50" Chuck

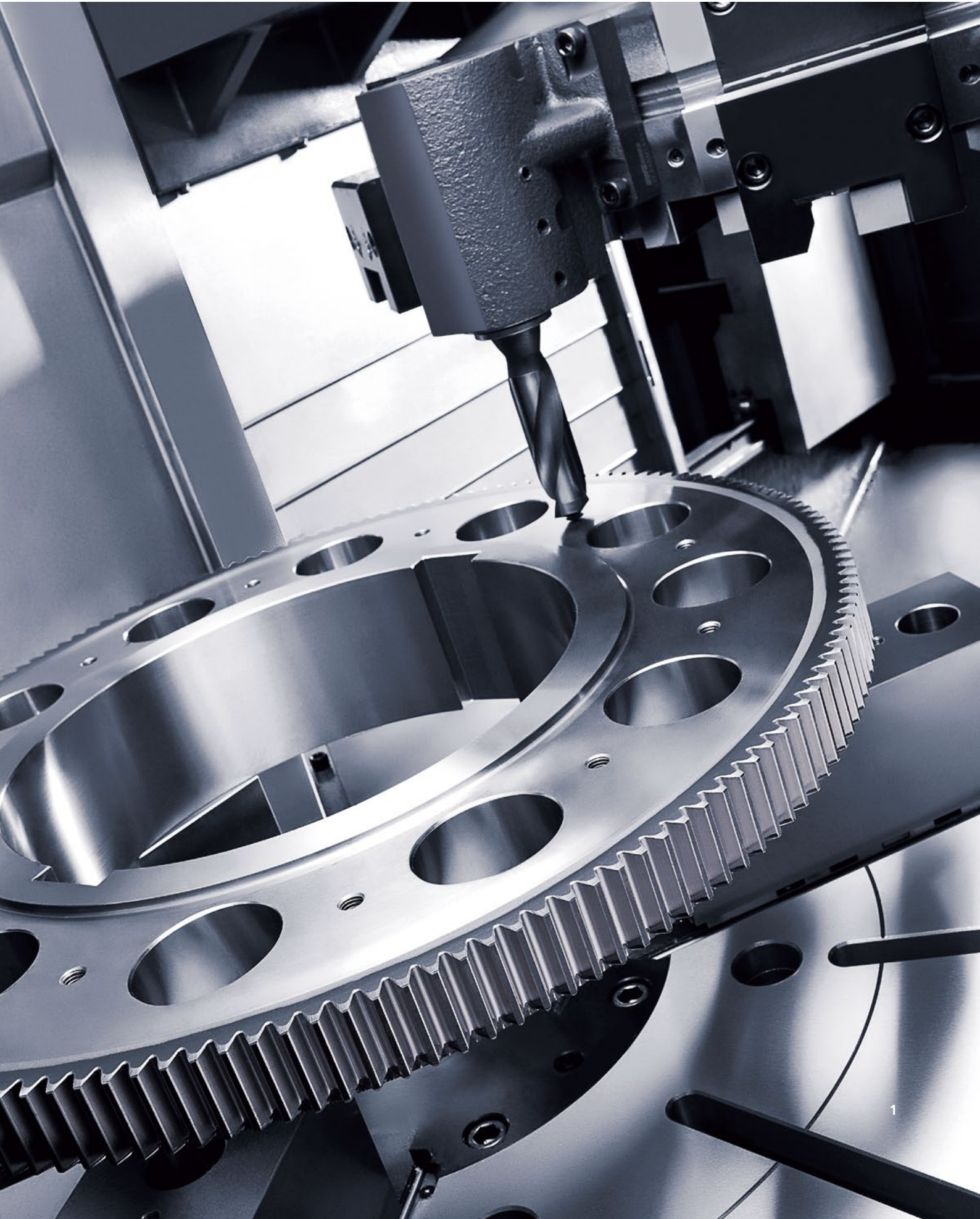



LARGE SIZE VERTICAL TURNING CENTER BUILT IN GEAR BOX WITH 24"-50" CHUCK

The machines can handle a variety of complex processes from turning to milling and drilling in one setting. With the heavy structure this turning centers can cut down your machining process and make your work more precise and productive.

1 Gear / Plant Industry / SCM415 2 BMT85 Turret for Turnmill
3 Flange / Sample / SM45C 4 50" Chuck 5 Piston / Shipment / FCD700

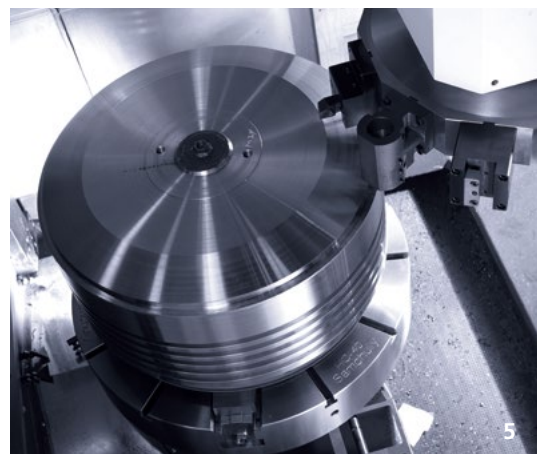
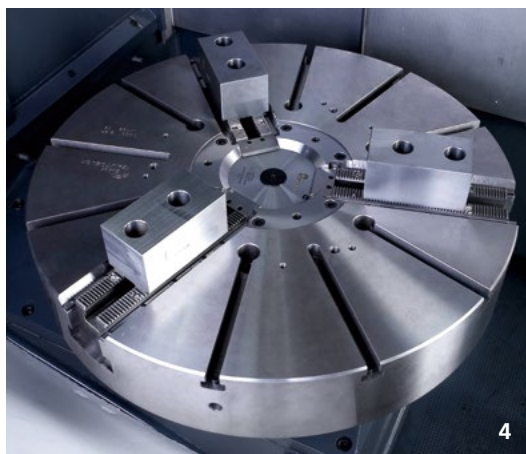
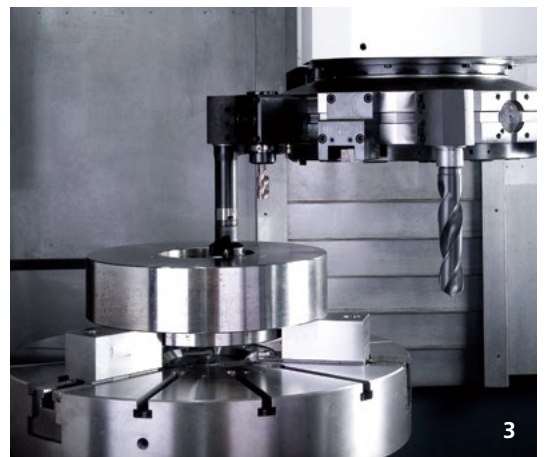
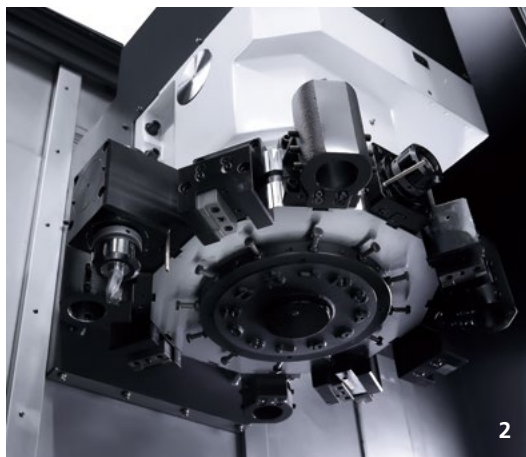

HEAVY DUTY CUTTING FOR LARGE WORKPIECES

VT-950/1150 vertical turning centers are the ideal machines for your large size applications. With the precision hand scraped and polished guide way system in all axes, the unique one piece machine bed design, this vertical centers are rigid and built to absorb vibration and best stability. Hwacheon's advanced air floating system keeps the operation stable and allows for smoothest operations.



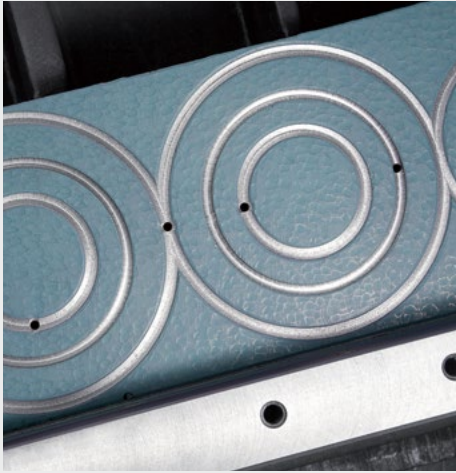

Box Way Design Including Air Floating System

The solid box way guide design used for all axes plus Hwacheon's proprietary air floating technology limit's vibrations and displacement which may occur from the friction heat.

Extra Rigid Machine Structure

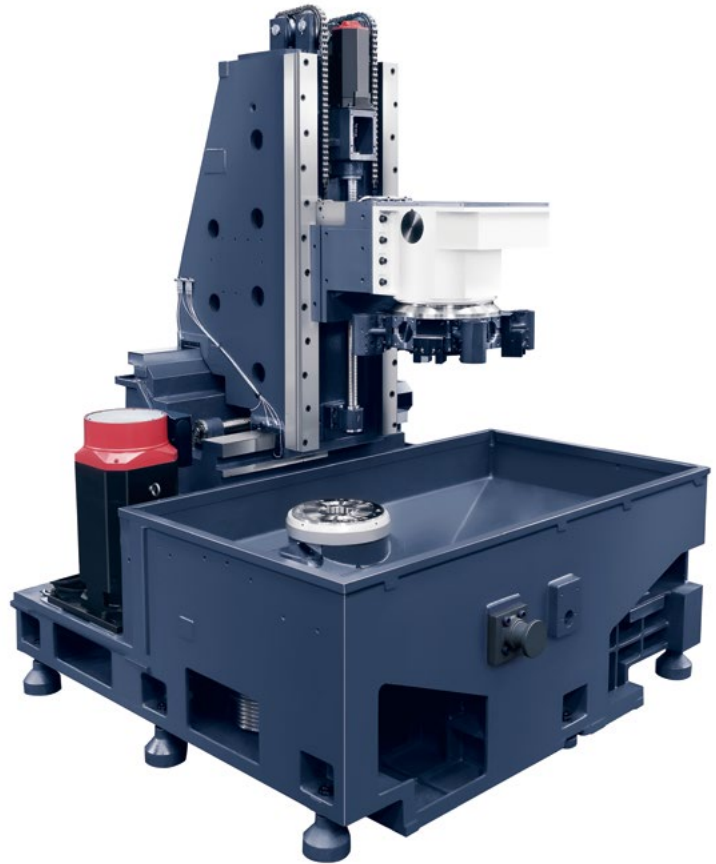

High Performance Integrated Gear System

The high performance spindle with a built-in high torque gear offers extra high torque at low speed operations and stability as well as precision.

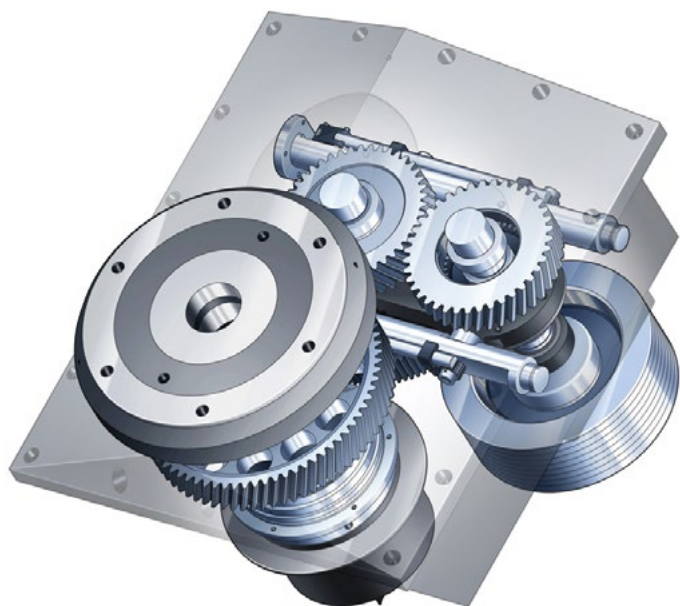
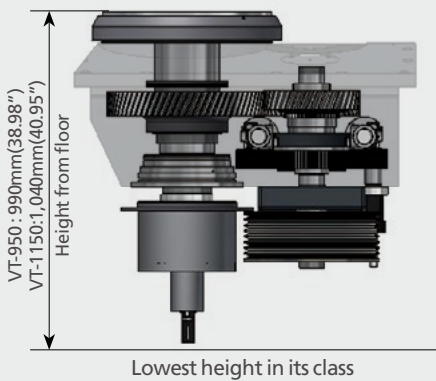

Interference Free Operation

The max. turning diameter zone is designed to provide interference free operations. Providing same max. diameter at full length even on larger work pieces.

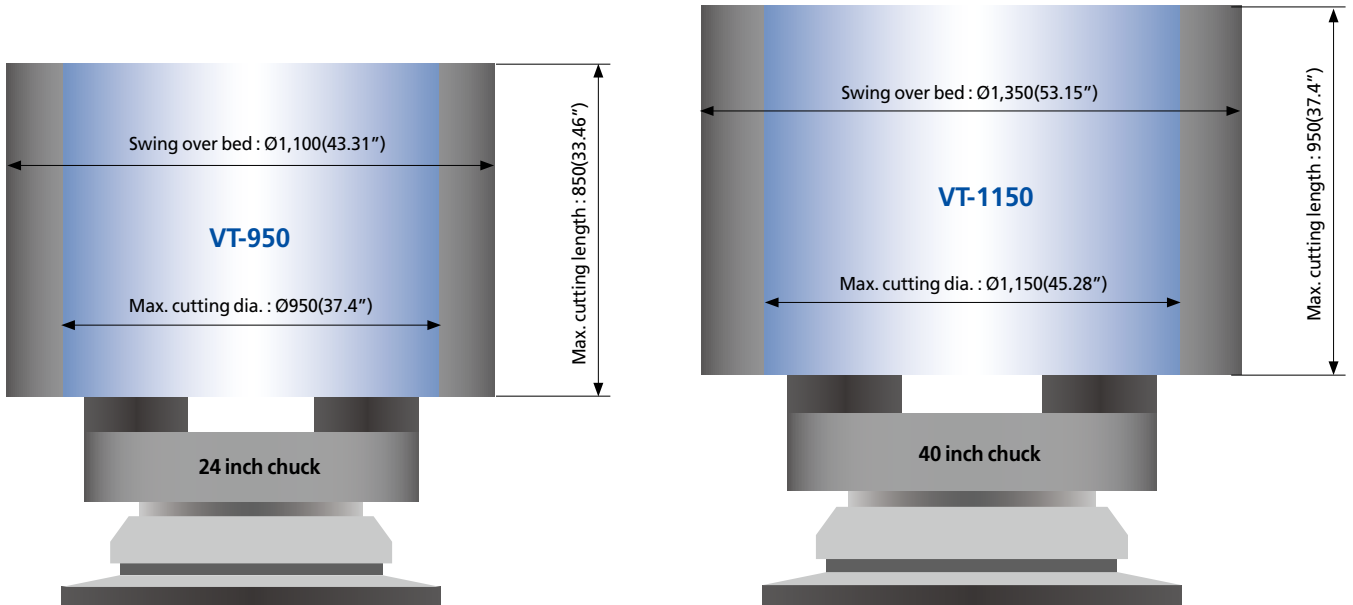

Environment-Friendly Design

To prevent the lubrication oil from dripping on the work piece surface during dry cutting, the cutting area and moving machine parts are completely separated. The environment-friendly machine design drains the lubricant oil separately and is eliminating the need for a separator unit.

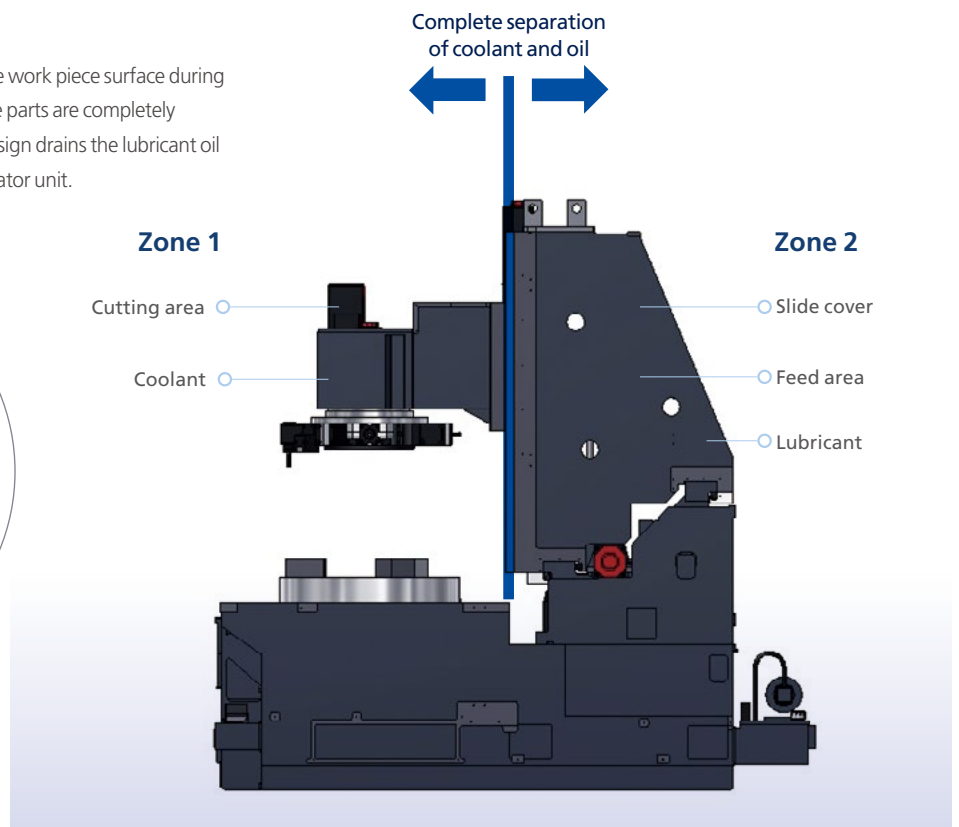
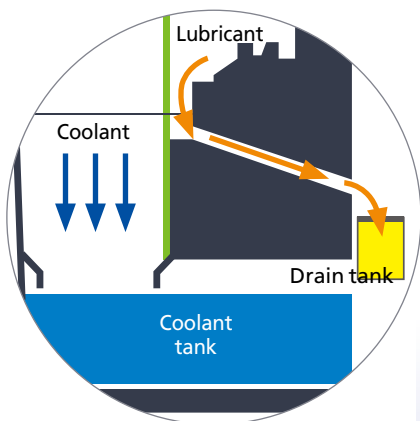



USER FRIENDLY DESIGN, A WIDE RANGE OF OPTIONAL FEATURES

VT-950/1150 vertical turning centers are designed with the user in mind. The user-friendly machine design and a variety of supplementary features make for stronger, faster, and more precise machining performance.

Fast Chip Removal

The wide, sloped slide cover design and the chip flushing at each side of the table remove the chips quickly and effectively.

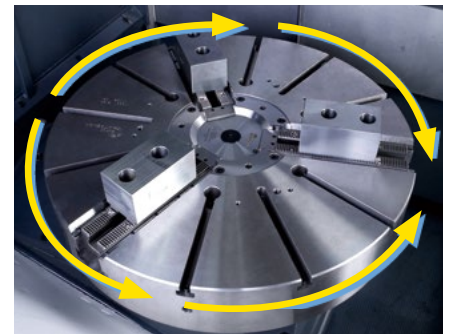

Coolant Bed Flushing

Best milling performance in its class

The milling system of the VT-950 and 1150 is powered by a high output spindle motor, the C-axis with 0.001-degree indexing allows the functionalities of a complete machining center in three axis simultaneously.

VT-950/1150 vertical turning centers perform turning, milling, drilling and tapping in one setting.

		VT-950	VT-1150
Capacity	Drilling End milling	Ø32mm(Ø1.25")	
	Tapping	M24	

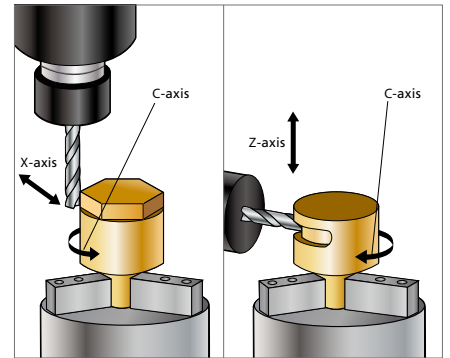

Turnmill(Optional)

L-HTLD: Hwacheon Lathe Tool Load Detect System (Option)



The Hwacheon Lathe Tool Load Detect System constantly detects and diagnoses the tool load under a process to prevent tool wear and damage, and to keep your machine and tools in optimal shape.

Load Detection Limit 1	Load Detection Limit 2
Alarm + Feed Hold	Alarm + Machine Stop
> When the LIMIT 1 Alarm sounds, the system holds the feed and the machine goes into standby.	> When the LIMIT 2 Alarm sounds, the system stops the machine, and must be reset to operate it.

Product Data

VT-950 VT-1150

* Unit: mm(inch)

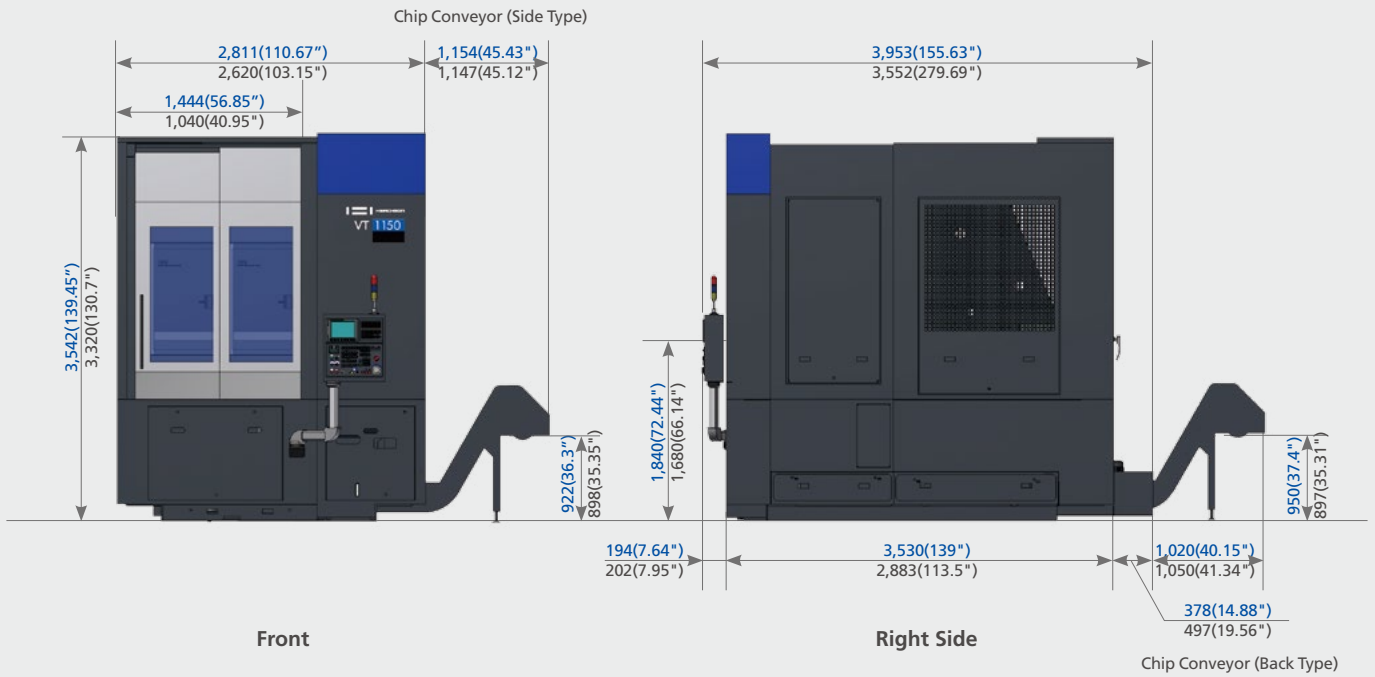

Spindle Power-Torque Diagram

VT-950(STD)

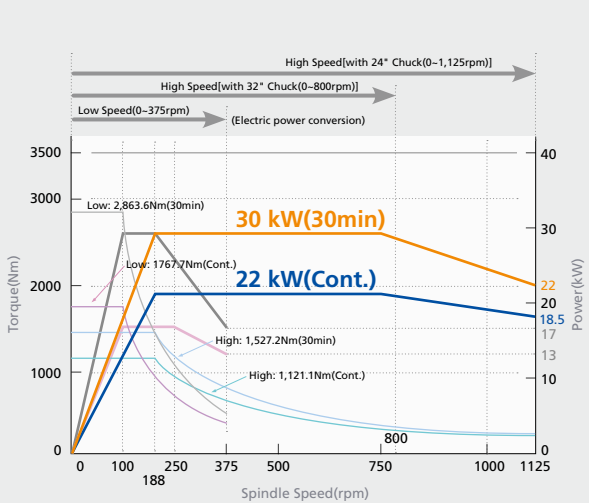

VT-1150(STD)

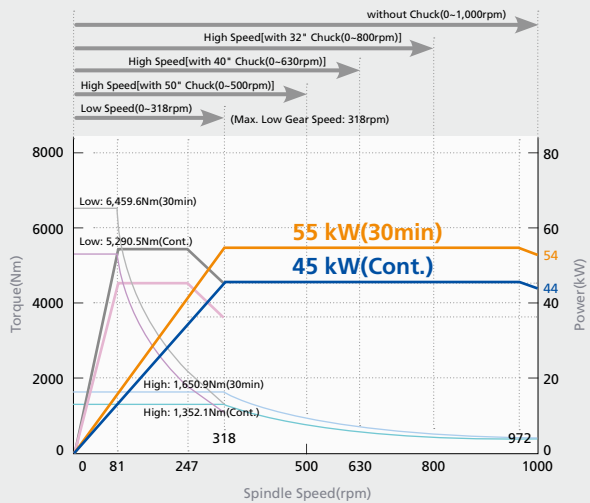

Tool Interference Diagram

※ Unit : mm(inch)

VT-950

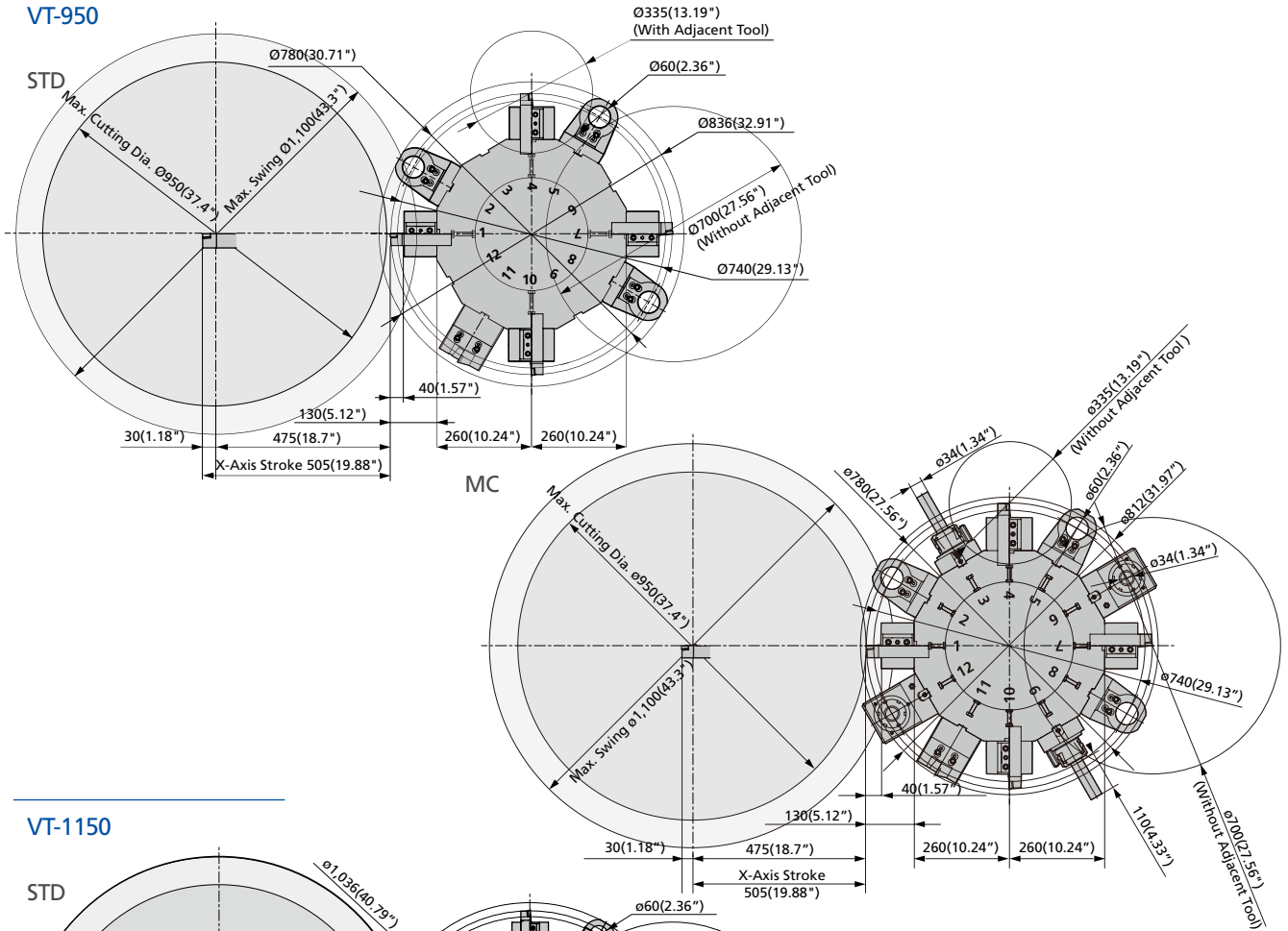

VT-1150

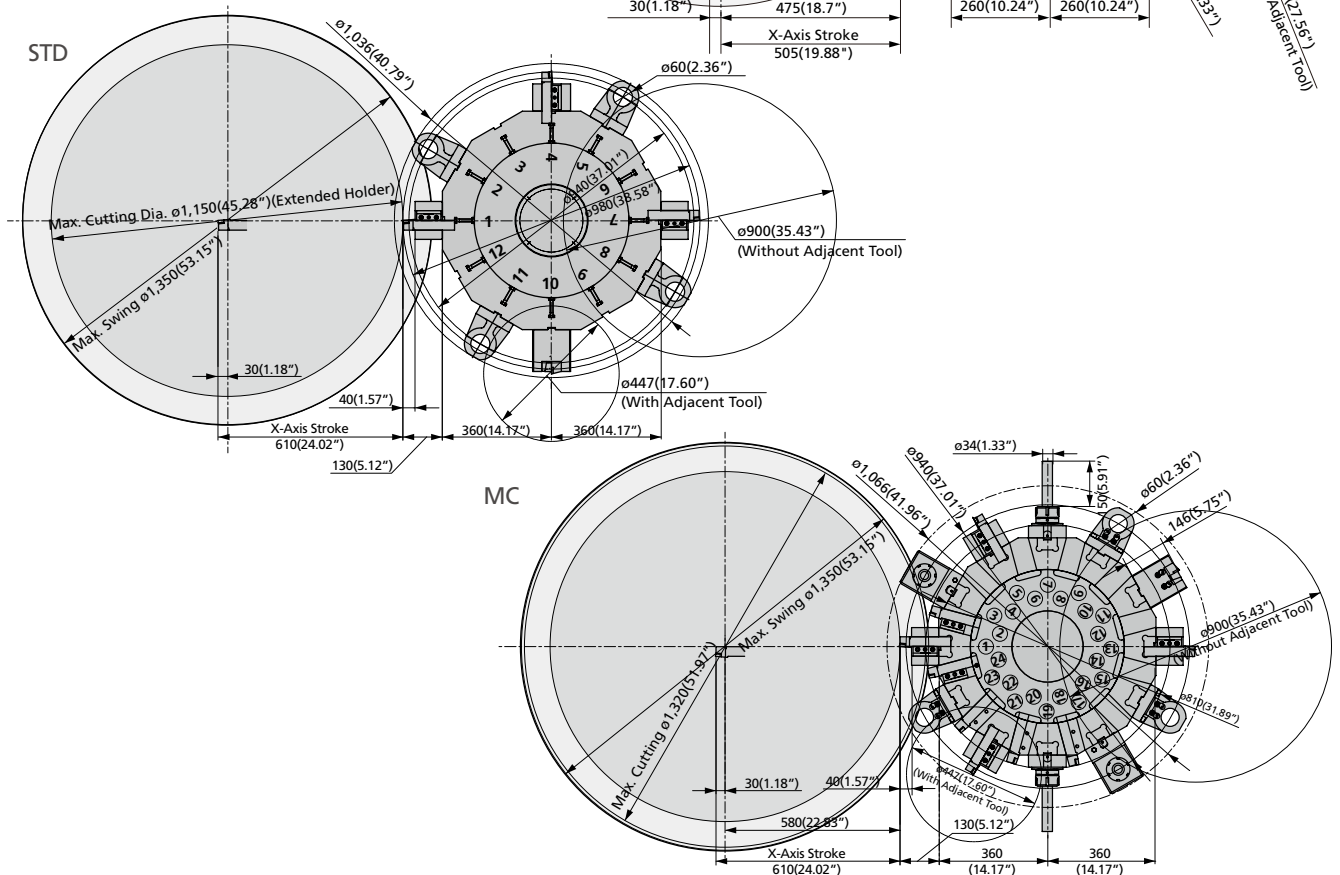

Moving Range

※ Unit: mm(inch)

VT-950

STD

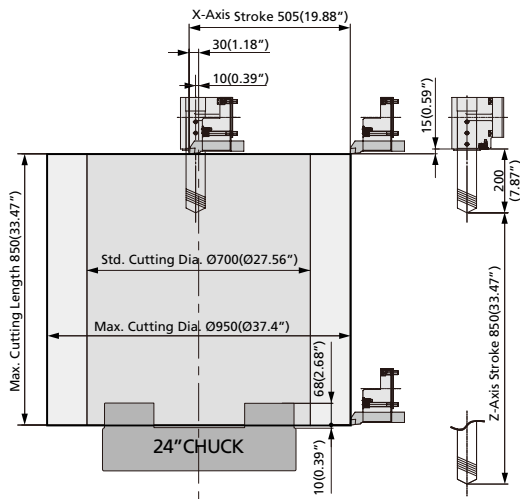

MC

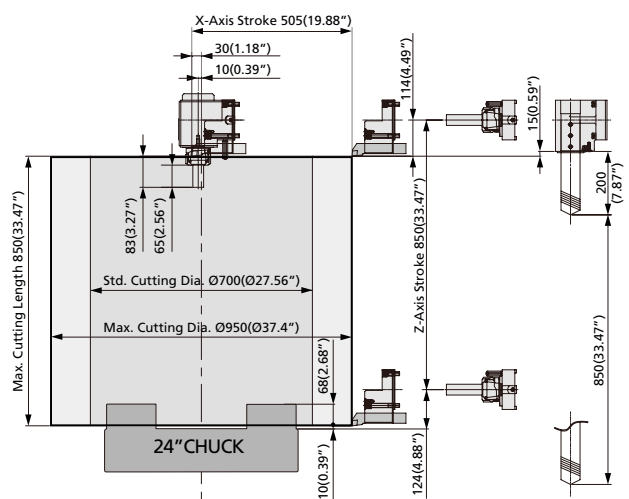

VT-1150

STD

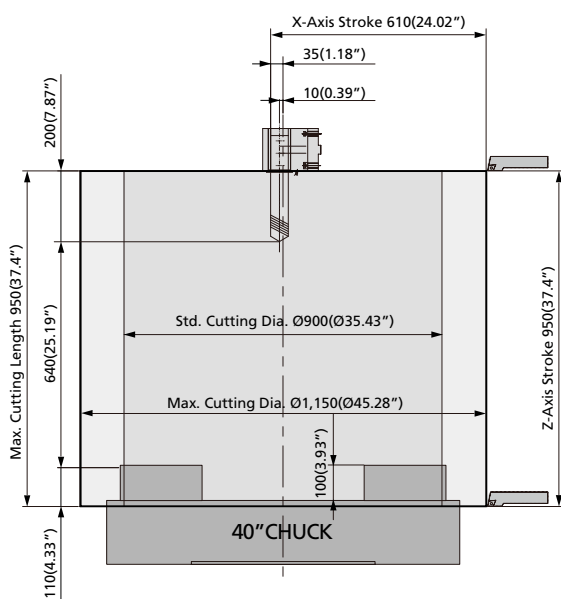

MC

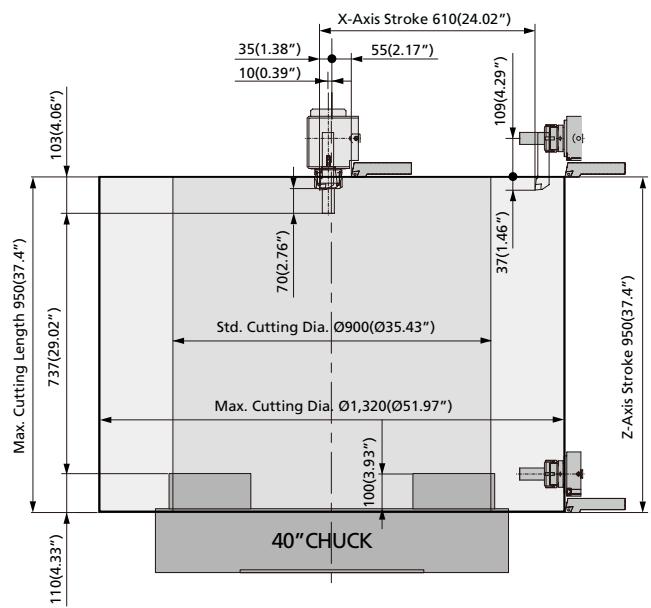

Product Configuration

Each product can be configured to fit your application.

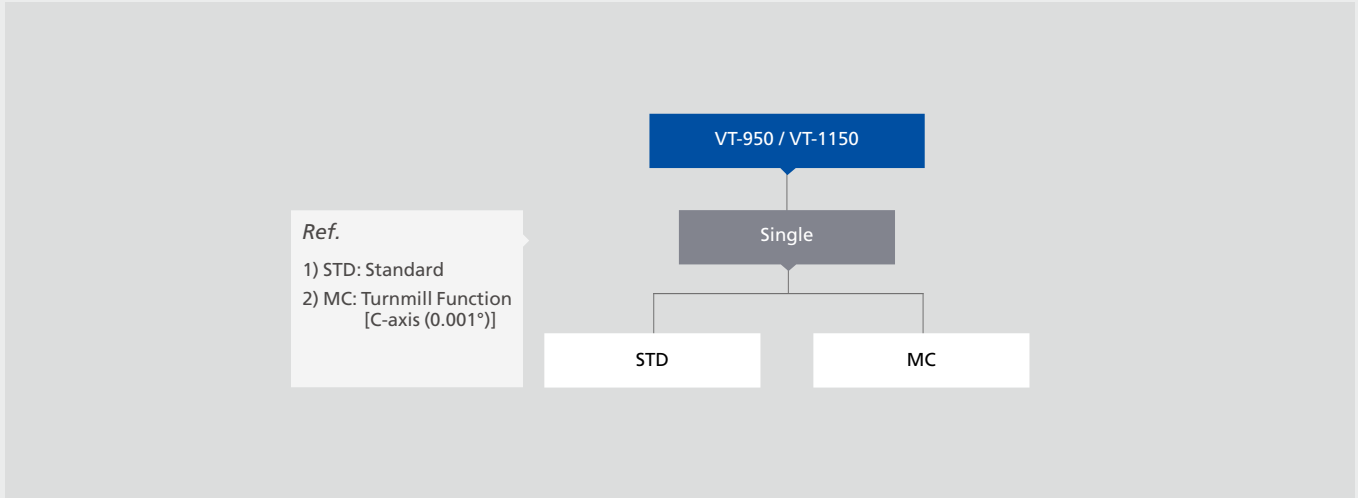

Machine Specifications

ITEM		VT-950	VT-950MC	VT-1150	VT-1150MC
Capacity					
Swing over Bed	mm(inch)	Ø1,100 (43.31")		Ø1,350 (53.15")	
Max. Cutting Diameter	mm(inch)	Ø950 (37.4")		Ø1,150 (45.28")	Ø1,320 (51.97")
Standard Cutting Diameter	mm(inch)	Ø700 (27.56")		Ø900 (35.43")	
Max. Cutting Length	mm(inch)	850 (33.46")		950 (37.40")	
Chuck Size	inch	24"(Opt.: 32")		40"(Opt.: 32"/ 50")	
Spindle					
Type of Spindle Nose	-	Ø380 Flat		Ø520 Flat	
Max. Spindle Speed	rpm	1,125		630	
Spindle Bearing Inner Diameter	mm(inch)	Ø200 (7.87")		Ø200 (7.87")	
Spindle Motor	kW(HP)	30 / 22 (40 / 30)		55 / 45 (73.5 / 60)	
Turret					
Number of Tool Station	ea	12		12	24
Tool Size	mm(inch)	□32 x Ø60 (□1.25" x Ø2.5")		□32 x Ø60 (□1.25" x Ø2.5")	
Turret Indexing Time	sec/step	0.18		0.2	
Axes					
Rapid Speed (X/Z)	m/min(ipm)	24 / 24(944.88/944.88)		24 / 24(944.88/944.88)	
Max. Stroke (X/Z)	mm(inch)	505 / 850 (19.88"/ 33.46")		610 / 950 (24.02"/ 37.40")	
Feed Motor (X/Z)	kW(HP)	7.0 / 7.0 (9.5 / 9.5)		6.0 / 6.0 (8 / 8)	
Turnmill (Opt.)					
Spindle Motor	kW(HP)	-	Opt 1: 7.5 / 5.5 (10 / 7.5) Opt 2: 11 / 7.5 (15 / 10)	-	Opt 1: 7.5 / 5.5 (10 / 7.5) Opt 2: 11 / 7.5 (15 / 10)
Max. Spindle Speed	rpm	-	3,000	-	3,000
Max. Drill/Tap Size	mm	-	Ø32 (1.25") / M24	-	Ø32 (1.25") / M24
Min. Index Angle	°(deg)	-	0.001°	-	0.001°
Tank Capacity					
Lubrication	ℓ(gal)	12 (3.17)		12 (3.17)	
Hydraulic	ℓ(gal)	50 (13.21)		50 (13.21)	
Coolant	ℓ(gal)	450 (120)		520 (137.37)	
Power Sources					
Electrical Power Supply	kVA	75		100	
Dimension					
Height	mm(inch)	3,320 (130.71")		3,542 (139.45")	
Floor Space (LxW)	mm(inch)	2,620 x 3,552 (103.15" x 139.84")		2,811 x 3,953 (110.67" x 155.63")	
Weight	kg,(lb _p)	15,000 (33,069)	15,100 (33,290)	24,000 (52,911)	24,100 (53,131)
NC Controller		Fanuc 0i-TD			

Standard and Optional product components

Common VT-950 VT-1150



Standard Accessories		Optional Accessories	
• Air Gun	• Manual & Parts List	• Air Blower	• Mist Collector
• Chuck Pressure Compensation	• Manual Guide i	• Auto Door	• NC Cooler
• Coolant System	• Set of Soft Jaws (24")	• Chip Conveyor & Bucket, Back Type / Side Type	• Set of Hard Jaws - 32"
• Door Interlock	• Set of Soft Jaws (40")	• Chuck Dual Pressure System	• Set of Hard Jaws - 32" / 40" / 50"
• Foot Switch	• Signal Lamp with 2 Colors (R, G)	• Chuck Pressure Check Switch	• Signal Lamp with 3 Colors (R,G,Y)
• High Pressure Pump 6bar	• Spindle Cooling System	• Chuck Pressure Compensation	• Tool & Work Counter, External / Internal
• Hydraulic Chuck & Cylinder (24" Solid)	• Tool Kit & Box	• Coolant Gun	• Tool Life Management
• Hydraulic Chuck & Cylinder (40" Solid)	• Tooling System	• Gap 120mm	• Tool Presetter (Automatic)
• Hydraulic Unit 40kg/cm ²	• Turret 12 Station	• High Pressure Pump 15bar	• Transformer
• Leveling Bolt & Plate	• Work Light	• Hydraulic Chuck, 32" / 50" Solid	• Turnmill Function Including C-axis (0.001)
• Linear Scale (X / Z)	• 10.4" Color LCD	• Independent Chuck, 32"(4-jaw)	- Opt 1 : α8 / 10,000i Motor
• Lubrication Unit		• Independent Chuck, 40" / 50" (4-jaw)	- Opt 2 : α8 / 10,000i Motor
		• L-HTLD (Lathe-Hwacheon Tool Load Detect)	• Turnmill Holder, Axial / Radial
		• Linear Scale (X / Z)	• U-Drill Holder
		• Magazine 16 Tools	

NC Specifications [Fanuc0i-TD]

※ - : Not available S : Standard O : Option

ITEM	SPECIFICATION	STD	MC	ITEM	SPECIFICATION	STD	MC
Controlled axis				Program input			
Controlled axis (Cs axis)	2-Axes	2-Axes	3-Axes	Programmable data input	G10	S	S
Simultaneously controlled axes	2-Axes	2-Axes	3-Axes	Sub program call	10 folds nested	S	S
Least input increment	0.001mm, 0.001deg, 0.0001inch	S	S	Custom macro B		S	S
Least input increment 1/10	0.0001mm, 0.0001deg, 0.00001inch	O	O	Addition of custom macro -common variables	#100-#199, #500-#999	S	S
inch/metric conversion	G20, G21	S	S	Canned cycles		S	S
Stored stroke check 1,2,3		S	S	Multiple repetitive cycle		S	S
Chamfering on/off		S	S	Multiple repetitive cycle II		S	S
Backlash compensation		S	S	Canned cycles for drilling		S	S
Operation				Small-hole peck drilling cycle		S	S
Automatic & MDI operation		S	S	Manual Guide i		S	S
Program number search		S	S	Spindle speed function			
Sequence number search		S	S	Constant surface speed control	G96 / G97	S	S
Dry run, single block		S	S	Spindle override	50 - 120%	S	S
Manual handle feed	1Unit	S	S	Spindle orientation		S	S
Manual handle feed rate	x1, x10, x100	S	S	Rigid tapping		O	S
Interpolation function				Spindle synchronous control		-	-
Positioning	G00	S	S	Tool function / compensation			
Linear interpolation	G01	S	S	Tool function	T4-digits	S	S
Circular interpolation	G02, G03	S	S	Tool offset pairs	64pairs	S	S
Dwell (Per seconds)	G04	S	S	Tool nose radius compensation		S	S
Polar coordinate interpolation	G12.1 / G13.1	-	S	Tool geometry/wear compensation		S	S
Cylindrical interpolation	G7.1	-	S	Tool life management		O	O
Threading	G32	S	S	Automatic tool offset	Tool presetter option is required	O	O
Multiple threading		S	S	Direct input tool offset value measured B	Tool presetter option is required	O	O
Threading retract		S	S	Editing operation			
Continuous threading		S	S	Part program storage length	1,280m(512kB)	S	S
Variable lead threading	G34	S	S	Number of register able programs	400ea	S	S
Reference position return 1st	G28	S	S	Background editing		S	S
Reference position return check	G27	S	S	Extended part program editing		S	S
2,3,4th reference position return	G30	S	S	Play back		S	S
Arbitrary speed threading		O	O	Operation/Display			
Feed function				Clock function		S	S
Rapid traverse override	F0, F25, F50, F100	S	S	Self-diagnosis function		S	S
Feed per minute (mm/min)	G98	S	S	Alarm history display		S	S
Feed per revolution (mm/rev)	G99	S	S	Help function		S	S
Rapid traverse bell-shaped acceleration/deceleration		S	S	Run hour and parts count display		S	S
Feedrate override	0 - 150 %	S	S	Graphic function		S	S
Jog feed override	0 - 1,260 mm/min	S	S	Multi-language display			
Program input					English, German, French, Italian, Chinese, Spanish, Korean, Portuguese, Polish, Hungarian, Swedish, Russia	S	S
Tape code	EIA RS244 / ISO840	S	S	Data input/output			
Optional block skip	1ea	S	S	Reader/Puncher interface CH1	RS232C	S	S
Program number	O4-Digits	S	S	Reader/Puncher interface CH2	RS232C	S	S
Sequence number	N5-Digits	S	S	Ethernet interface	Embedded Ethernet	S	S
Decimal point programming		S	S	Memory card interface		S	S
Coordinate system setting	G50	S	S	USB card interface		S	S
Coordinate system shift		S	S	Others			
Workpiece coordinate system	G54 - G59	S	S	Display unit	10.4" Color LCD	S	S
Workpiece coordinate system preset	G92.1	S	S				
Direct drawing dimension programming		S	S				
G code system	A	S	S				

Hwacheon Global Network

 Hwacheon Headquarter  Hwacheon America  Hwacheon Europe  Hwacheon Asia



HWACHEON

Please call us for product inquiries.

www.hwacheon.com

The product design and specifications may change without prior notice.
Read the operation manual carefully and thoroughly before operating the product,
and always follow the safety instructions and warnings labels attached on the surfaces of the machines.

HEAD OFFICE

HWACHEON MACHINE TOOL CO., LTD

976-1, JANGDEOK-DONG GWANGSAN-GU, GWANGJU, KOREA
TEL: +82-62-951-5111 FAX: +82-62-951-0086

SEOUL OFFICE

1022-7, BANGBAE-DONG, SEOCHO, SEOUL, KOREA
TEL: +82-2-523-7766 FAX: +82-2-523-2867

USA

HWACHEON MACHINERY AMERICA, INC.

555 BOND STREET, LINCOLNSHIRE, ILLINOIS, 60069, USA
TEL: +1-847-573-0100 FAX: +1-847-573-9900

SINGAPORE

HWACHEON ASIA PACIFIC PTE. LTD.

21 BUKIT BATOK CRESCENT, #08-79 WCEGA TOWER SINGAPORE 658065
TEL: +65-6515-4357 FAX: +65-6515-4358

GERMANY

HWACHEON MACHINERY EUROPE GMBH

JOSEF-BAUMANN STR. 25, 44805, BOCHUM, GERMANY
TEL: +49-2349-128160 FAX: +49-2349-1281660